

Series F



0101

General Description _____	1
Unit Designations _____	2
Explanation and use of Ratings and Service Factors _____	3
Load Classification by Applications _____	4
Selection Procedure _____	5 - 6
Exact Ratios _____	7 - 8
Mounting Positions _____	9
Lubrication _____	10
Output Options _____	11 - 12
Motor Adaptors _____	13
Additional Features _____	14
Series X Couplings _____	15
MOTORISED	
Motor Performance Data and Standard Motor Variants Available _____	17 - 18
Brake Motors / Motors Available _____	19
Motor Details _____	20
Selection Tables - Geared Motors _____	21 - 59
Dimension Sheets - Geared Motors _____	60 - 67
Motorised Backstop Module _____	68
REDUCER	
Overhung & Axial Loads on Shafts _____	71 - 72
Moments of Inertia _____	73 - 74
Ratings - Input Power / Output Torque _____	75 - 94
Dimension Sheets - Speed Reducers _____	95 - 102
Dimension Sheet - Torque Bush _____	103
Dimension Sheet - Assembly / Disassembly _____	104
Shipping Specification _____	105 - 107
Thermal Power Ratings / Dimensions of Units with Fans _____	108 - 109
Taper Release Bushing _____	110 - 111
Reducer Backstop Module _____	112

SERIES F

GENERAL DESCRIPTION

0004

Series F

Series F in-line shaft mounted geared motors offer ratios from 5/1 to 100/1 in double reduction form and in combined unit form up to 20,000/1. Motors are available up to 45 kW giving a maximum output torque of 7200 Nm.

The Series F geared motor is primarily designed as a shaft mounted unit incorporating an integral torque reaction bracket. The units are also available with bolt-on feet or output flanges and output shafts of single and double extension. All variants are available either motorised or with input shaft assembly.

Adding to the new range of Textron Power Transmission geared motors this product takes advantage of our many years of accumulated design expertise, together with the use of high quality materials and components. The end result is a series of speed reducing geared motors offering high load carrying capacity, increased efficiency, quiet running and reliability.

The Range Includes

Six sizes of units

F04, F06, F07, F08, F09 and F10.

- Version T - Standard unit with torque bush
- Version W - Standard unit without torque bush
- Version B - Standard unit with base or top mounted feet
- Version F - Standard unit with output flange

- Unit type M - Motorised
- Unit type G - Unit to allow fitting of a non standard Textron (IEC) motor
- Unit type A - Unit to allow fitting of NEMA motor
- Unit type R - Reducer
- Unit type S - Reducer unit fitted with a fan
- Unit type X - Reducer unit fitted with a backstop
- Unit type Y - Reducer unit with a fan & backstop

Design Features Include

Patented standard motor connection (IEC or NEMA).

Ability to fit double oil seals input and output as required.

All units are dimensionally interchangeable with other major European manufacturers.

Brake geared motors are available as standard.

Units are manufactured and assembled from a family of modular kits for distributor friendliness minimising inventory and maximising availability.

Motorised units can be fitted with a backstop module and reducer units can be fitted with a backstop and fan.

As improvements in design are being made continually this specification is not to be regarded as binding in detail and drawings and capacities are subject to alteration without notice. Certified drawings will be sent on request.

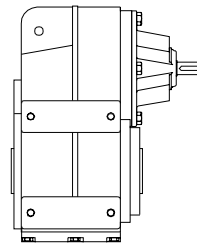

Double reduction shaft mounted reducer

* F 0 4 2 0 5 0 . W R H - 1 - - - - - - -

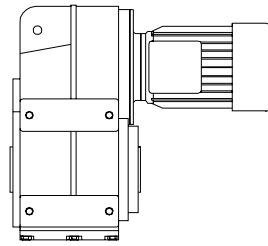

Motorised double reduction shaft mount

* F 0 4 2 0 5 0 . W M H - 1 A . 7 5 4 A -

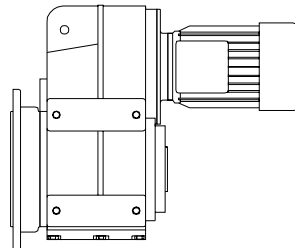

Motorised double reduction hollow output bore with output flange

* F 0 4 2 0 5 0 . F M H - 1 A . 7 5 4 A -

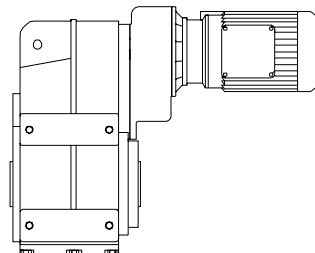

Motorised triple reduction shaft mount

* F 0 4 3 0 1 0 0 W M H - 1 A . 2 5 4 A -

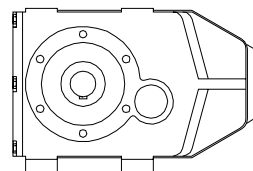

Double reduction reducer with base mounted feet and standard output shaft

* F 0 4 2 0 5 0 . B R C - 4 - - - - - - -

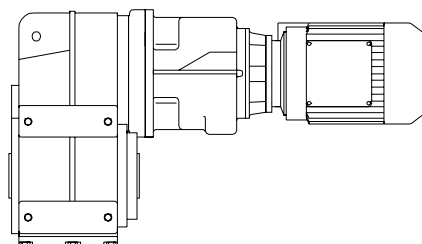

Motorised quadruple reduction shaft mount

* F 0 8 4 0 9 0 0 W M H - 1 A . 3 7 4 A -

* Typical unit designations

SERIES F

UNIT DESIGNATIONS

0004

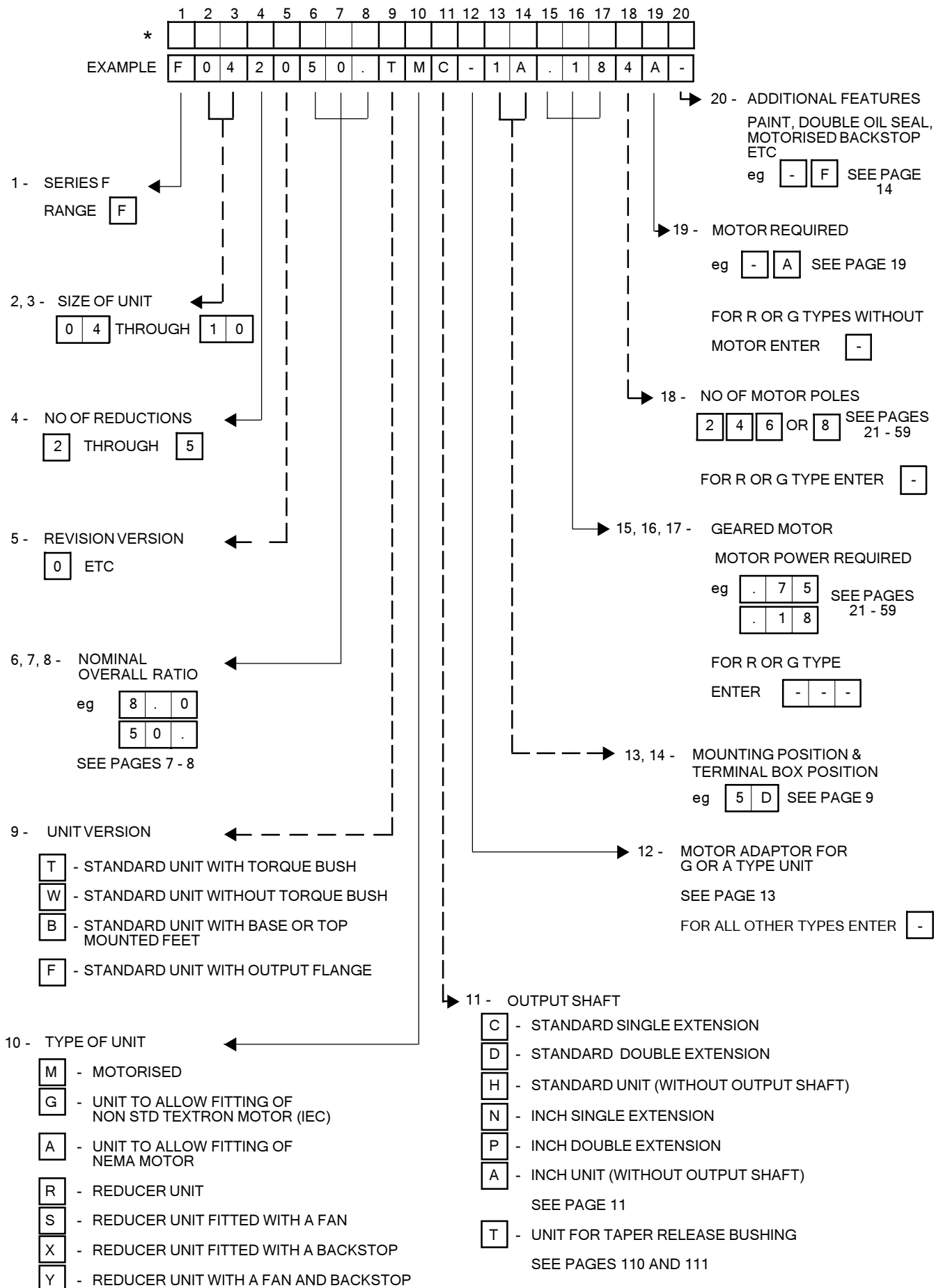

* THIS PAGE MAY BE PHOTOCOPIED ALLOWING THE CUSTOMER TO ENTER THEIR ORDER

SERIES F

EXPLANATION & USE OF RATINGS & SERVICE FACTORS

0008

Gear unit selection is made by comparing actual loads with catalogue ratings. Catalogue ratings are based on a standard set of loading conditions, whereas actual load conditions vary according to type of application. Service Factors are therefore used to calculate an equivalent load to compare with catalogue ratings.

i.e. Equivalent Load = Actual Load x Service Factor

Mechanical ratings and service factor Fm

Mechanical ratings measure capacity in terms of life and/or strength, assuming 10 hours per day continuous running under uniform load conditions.

Catalogue ratings allow 100% overload at starting, braking or momentarily during operation up to 10 hours per day.

The unit selected must therefore have a catalogue rating at least equal to half maximum overload.

Mechanical Service Factor Fm (Table 1) is used to modify the actual load according to daily operating time, and type of loading.

Load characteristics for a wide range of applications are detailed in Table 2 opposite, which are used in deciding the appropriate Service Factor Fm from Table 1.

If overloads can be calculated, or accurately assessed, actual loads should be used instead of Fm.

For applications where units are to operate in extremely dusty or moist/humid atmospheres unit selection should be referred to Textron Power Transmission application engineers.

Table 1 Mechanical service factor Fm

Prime mover	Duration of service-hours per day	Load classification-driven machine		
		Uniform	Moderate Shock	Heavy Shock
Electric motor, steam turbine or hydraulic motor	Under 3	0.80	1.00	1.50
	3 to 10	1.00	1.25	1.75
	Over 10	1.25	1.50	2.00
Multi-cylinder internal combustion engine	Under 3	1.00	1.25	1.75
	3 to 10	1.25	1.50	2.00
	Over 10	1.50	1.75	2.25
Single cylinder internal combustion engine	Under 3	1.25	1.50	2.00
	3 to 10	1.50	1.75	2.25
	Over 10	1.75	2.00	2.50

LOAD CLASSIFICATION BY APPLICATIONS

0004

Table 2

U = Uniform load

M = Moderate shock load

H = Heavy shock load

† = Refer to Textron Power Transmission

		Driven Machine	type of load	Driven Machine	type of load	Driven Machine	type of load
		Cranes		log haul-incline	H	log haul	H
		main hoists	U	log haul-well type	H	presses	M
		bridge travel	†	log turning device	H	pulp machine reel	M
		trolley travel	†	main log conveyor	H	stock chest	M
				off bearing rolls	M	suction roll	M
		Crusher		planer feed chains	M	washers and thickeners	M
		ore	H	planer floor chains	M	winders	M
		stone	H	planer tilting hoist	M		
		sugar	H	re-saw merry-go-round conveyor	M	Printing presses	†
				roll cases	H	Pullers	
		Dredges		slab conveyor	H	barge haul	H
		cable reels	M	small waste conveyor-belt	U	Pumps	
		conveyors	M	small waste conveyor-chain	M	centrifugal	U
		cutter head drives	H	sorting table	M	proportioning	M
		jig drives	H	tipple hoist conveyor	M	reciprocating	
		manoeuvring winches	M	tipple hoist drive	M	single acting; 3 or more cylinders	M
		pumps	M	transfer conveyors	M	double acting; 2 or more cylinders	M
		screen drive	H	transfer rolls	M	single acting; 1 or 2 cylinders	M
		stackers	M	tray drive	M	double acting; single cylinder	†
		utility winches	M	trimmer feed	M	rotary	
				waste conveyor	M	gear type	U
		Dry dock cranes				lobe, vane	U
		main hoist	†	Machine tools			
		auxiliary hoist	†	bending roll	M	Rubber and plastics industries	
		boom, luffing	†	punch press-gear driven	H	crackers	H
		rotating, swing or slew	†	notching press- belt driven	†	laboratory equipment	M
		tracking, drive wheels	†	plate planers	H	mixed mills	H
				tapping machine	H	refiners	M
		Elevators		other machine tools		rubber calenders	M
		bucket-uniform load	U	main drives	M	rubber mill-2 on line	M
		bucket-heavy load	M	auxiliary drives	U	rubber mill-3 on line	M
		bucket-continuous	U			sheeter	M
		centrifugal discharge	U	Metal mills		tire building machines	†
		escalators	U	draw bench carriage and main drive	M	tire and tube press	
		freight	M	pinch, dryer and scrubber rolls-reversing	†	openers	†
		gravity discharge	U	slitters	M	tubers and strainers	M
		man lifts	†	table conveyors		warming mills	M
		passenger	†	non-reversing			
				group drives	M	Sand muller	M
		Fans		individual drives	H		
		centrifugal	U	reversing		Sewage disposal equipment	
		cooling towers		wire drawing and flattening machine	M	bar screens	U
		induced draft	†	wire winding machine	M	chemical feeders	U
		forced draft	†			collectors	U
		induced draft	M	Mill-rotary type		dewatering screws	M
		large, mine, etc	M	ball	H	scum breakers	M
		large, industrial	M	cement kilns	H	slow or rapid mixers	M
		light, small diameter	U	dryers and coolers	H	thickeners	M
				kilns, other than cement	H	vacuum filters	M
		Feeders		pebble rod	H		
		apron	M	plain	H	Screens	
		belt	M	wedge bar	H	air washing	U
		disc	U	tumbling barrels	H	rotary-stone or gravel travelling water intake	U
		reciprocating	H			Slab pushers	M
		screw	M	Mixers		Steering gear	†
				concrete mixers		Stokers	U
		Generators-not welding	U	-continuous	M		
				concrete mixers		Sugar industry	
		Hammer mills	H	-intermittent	M	cane knives	M
				constant density	U	crushers	M
		Hoists		variable density	M	mills	M
		heavy duty	H	Oil industry			
		medium duty	M	chillers	M	Textile industry	
		skip hoist	M	oil well pumping	†	batchers	M
				paraffin filter press	M	calenders	M
		Laundry washers		rotary kilns	M	cards	M
		reversing	M	Paper mills		dry cans	M
				agitators, (mixers)	M	dryers	M
		Laundry tumblers	M	barker-auxiliaries-hydraulic	M	dyeing machinery	M
				barker-mechanical	H	knitting machines	†
		Line shafts		barking drum	H	looms	M
		driving processing equipment	M	beater and pulper	M	mangles	M
		light	U	bleacher	U	nappers	M
		other line shafts	U	calenders	M	pads	M
				calenders-super	H	range drives	†
		Lumber industry		converting machine, except cutters, platers	M	slashers	M
		barkers-hydraulic-mechanical	M	conveyors	U	soapers	M
		burner conveyor	M	couch	M	spinners	M
		chain saw and drag saw	H	cutters-plates	H	tenter frames	M
		chain transfer	H	cylinders	M	washers	M
		craneway transfer	H	dryers	M	winders	M
		de-barking drum	H	felt stretcher	M		
		edger feed	M	felt whipper	H	Windlass	†
		gang feed	M	jordans	M		
		green chain	M				
		live rolls	H				
		log deck	H				

SERIES F

SELECTION PROCEDURE

0101

1.0 UNIT TYPE SELECTION

Select the type of unit required ie whether a geared motor (if so continue to follow these instructions) or the reducer type (if so start at paragraph 3.0)

2.0 GEARED MOTOR SELECTION

2.1 UNITS FITTED WITH A TEXTRON POWER TRANSMISSION STD MOTOR

- (i) Calculate absorbed power (kW) to drive designated driven machine.
- (ii) Determine for driven machine the load classification from information given in table 2 page 4.
- (iii) Determine the required service factor (FM) in accordance with load classification and daily operating hours see table 1 page 3.
- (iv) Turn to section tables geared motors page 21 to 59. Choose motor power closest above the required absorbed power. (Selection of 4 pole motor will give the lowest cost and shortest delivery lead times).

Having knowledge of the driven machine required speed (output speed from geared motor N_2) choose nearest speed and check service factor is adequate.

NB Service factor can be enhanced as follows.

$$\text{Actual service factor} = \frac{\text{Stated service factor} \times \text{Motor power}}{\text{Absorbed power}}$$

- (v) Check points raised in paragraph 4.0

Example 1

A shaft mounted motorised Series F gear unit is required to drive a belt conveyor handling material which is uniformly loaded onto the belt. The conveyor has to operate 24 hours per day and the stated absorbed power is 0.7 kW at an input speed of 31 rev/min.

Further a standard output bore and mounting position 1 (see page 9) are required with torque retaining bush.

Following the procedure specified in paragraph 2.1 we have

- (i) The load classification for this application is designated as uniform.
- (ii) The drive requires a minimum mechanical service factor (FM) of 1.25.
- (iii) The next larger motor above the absorbed power is 0.75 kW from page 32 under 4 pole motors and at $N_2 = 31$ rev / min, therefore the gear unit selection is

F	0	4	2	0	4	5	.	W	M	H	-	1	A	.	7	5	4	A	-
---	---	---	---	---	---	---	---	---	---	---	---	---	---	---	---	---	---	---	---

which has a service factor of 1.3 at full motor power.

$$\text{Actual service factor} = \frac{0.75 \times 1.3}{0.7} = \mathbf{1.39}$$

2.2 GEARED MOTOR CUSTOMER TO FIT THE MOTOR

- (i) Calculate the required absorbed power (kW) for the driven machine and choose the appropriate motor.
- (ii) Then determine the load classification and hence required mechanical service factor (FM) as paragraph 2.1 (ii) and (iii).
- (iii) Calculate unit ratio = $\frac{\text{Input Speed}}{\text{Output Speed}}$ and determine the number of reduction stages using exact gear ratio tables on pages 7 - 8.
- (iv) Calculate the required mechanical rating of the gear unit

$$P_{\text{mech}} = \text{Absorbed Power} \times \text{Service Factor}.$$
- (v) Using rating tables pages 75 to 94 select size of unit with required mechanical rating.
- (vi) Check the motor is suitable for mounting on the selected gear unit referring to page 13.
- (vii) Check points raised in paragraph 4.0.

Example 2

A shaft mounted unit is to be fitted by the customer with a 1.5 kW 1450 rev/min motor a 90L B14 C frame. The output shaft is to rotate at 58 rev/min and is to be coupled to an industrial fan which operates 8 hours per day.

SERIES F

SELECTION PROCEDURE

0101

Following the procedure specified in paragraph 2.2, we have

- (i) The load classification for this application is moderate shock.
- (ii) The drive requires a minimum mechanical service factor of 1.25.
- (iii) Required unit ratio = $\frac{1450}{58}$ * ie. 25/1 * Check motor supplier's data for actual speed.
- (iv) Referring to exact ratio table, a double reduction nominal ratio 25/1 is required and mechanical rating requirement of:-
 $P_{mech} = 1.25 \times 1.5$, ie. 1.875 kW.
- (v) Referring to the unit mechanical rating table, page 79, the M0420 has a capacity of 2.33 kW hence adequate for the application.
- (vi) Referring to page 13, it can be seen that to attach the 90L Frame B14 C face motor to the F0420 unit, the motor adaptor D is required which is entered in column 12 of the unit designation.
- (vii) The unit designation for this application is

F	0	4	2	0	2	5	.	W	G	H	D	1	-	-	-	-	-	-
---	---	---	---	---	---	---	---	---	---	---	---	---	---	---	---	---	---	---

3.0 REDUCER UNIT SELECTION

- (i) Calculate the unit ratio = $\frac{\text{Input Speed}}{\text{Output Speed}}$ and hence from the ratio the number of reductions required (see pages 7 - 8)
- (ii) Determine the load classification and mechanical service factor as paragraph 2.1 (ii) and (iii).
- (iii) Calculate the required mechanical torque rating
 $T_{mech} = \frac{\text{Absorbed Power} \times 9550 \times \text{Mechanical Service Factor}}{\text{Input Speed Driven Machine}}$
- (iv) Using unit mechanical rating tables, pages 75 to 94, select appropriate unit.
- (v) Check for the chosen unit that actual output speed is that required using exact ratio tables, pages 7 - 8 and prime mover speed.
- (vi) Check points raised in paragraph 4.0.

Example 3 Using Example 1 again but unit with base feet and standard output shaft.

- (i) We know the absorbed power is 0.7 kW and the load classification operating conditions demand a minimum mechanical service factor of 1.25.
- (ii) Unit ratio = $\frac{1450}{31}$ ie 46.77/1 From the exact ratio tables a nominal ratio of 45/1 will be used for the unit selection.
- (iii) Required $T_{mech} = 0.7 \times \frac{9550}{31} \times 1.25 = 270\text{Nm}$.
- (iv) From the unit rating tables the F0420 45/1 has a torque capacity of 350Nm. Hence the selection is adequate for the application.
- (v) If Textron Power Transmission supplied the motor the actual motor speed would be 1380 rev/min, this together with exact ratio of 21.99 yields:-

Input speed to Driven machine = $\frac{1380}{45.14}$ ie 30.57 rev/min.

- (vi) The input designation for this application is

F	0	4	2	0	4	5	.	B	R	C	-	4	-	-	-	-	-	-
---	---	---	---	---	---	---	---	---	---	---	---	---	---	---	---	---	---	---

4.0 ADDITIONAL INFORMATION

- (i) Gear unit overload capacity is 2.0 x mechanical rating, 10 times per day.
- (ii) If the unit is subject to overhung loads or axial thrusts, check these can be accommodated, see pages 21 to 59 geared motors or page 71 and 72 gear reducers.
- (iii) If the $\frac{\text{Inertia of the Driven Machine (Referred to Motor Speed)}}{\text{Inertia of Gear Unit plus Motor}} > 1.0$
then consult Textron Power Transmission Application Engineers.
The Motor and Gear Unit inertias are obtained from pages 17, 18 and 73, 74 respectively.
- (iv) If the ambient temperature is above 40°C then consult Textron Power Transmission Application Engineers.

SERIES F

EXACT RATIOS

9608

EXACT RATIOS - DOUBLE REDUCTION

NOMINAL RATIO COLUMN ENTRY 6 7 8	F0420	F0620	F0720	F0820	F0920	F1020
	5 . 0	5.113	5.031	5.151	5.088	5.085
6 . 3	6.320	6.273	6.420	6.242	6.567	6.433
7 . 1	7.172	7.074	7.136	7.212	7.000	7.133
8 . 0	7.903	7.928	8.016	8.012	7.846	7.758
9 . 0	8.975	8.900	8.813	8.912	8.807	8.812
1 0 .	9.768	9.886	9.990	9.830	10.13	9.772
1 1 .	11.40	11.30	11.51	11.52	11.35	11.48
1 2 .	12.95	12.81	13.09	12.94	12.68	12.39
1 4 .	14.09	14.09	14.35	14.14	14.66	14.46
1 6 .	16.01	15.97	16.31	15.87	16.37	15.61
1 8 .	17.63	17.59	17.48	17.88	17.58	18.07
2 0 .	20.03	20.46	20.09	20.81	20.04	20.46
2 2 .	21.79	21.94	21.79	21.93	22.70	22.76
2 5 .	24.75	25.51	25.04	25.53	25.88	25.77
2 8 .	28.82	28.92	28.77	28.58	28.41	28.04
3 2 .	31.33	30.88	32.53	32.26	31.56	31.16
3 6 .	35.62	36.06	35.86	35.06	36.69	35.32
4 0 .	38.72	38.50	40.55	39.58	40.76	39.25
4 5 .	45.14	45.18	44.99	45.60	44.58	44.43
5 0 .	50.86	49.47	49.27	50.09	49.22	51.19
5 6 .	55.79	56.34	56.07	55.95	57.58	55.97
6 3 .	62.86	61.69	61.40	61.46	63.56	64.49
7 1 .	67.10	67.58	68.02	67.04	67.71	69.24
8 0 .	76.29	75.79	75.58	77.20	76.14	74.39
9 0 .	82.94	84.26	84.78	82.25	87.44	87.21
1 0 0	94.29	94.50	94.20	94.71	98.32	93.70

EXACT RATIOS - TRIPLE REDUCTION

NOMINAL RATIO COLUMN ENTRY 6 7 8	F0430	F0630	F0730	F0830	F0930	F1030
	6 3 .	63.92	63.48	63.46		
7 1 .	73.05	72.12	73.81			
8 0 .	79.00	79.15	79.09			
9 0 .	90.28	89.92	91.99			
1 0 0	98.59	103.8	104.3	103.3	102.5	102.8
1 1 2	115.5	112.8	111.4	116.6	113.9	114.2
1 2 5	121.9	129.4	130.0	126.8	132.3	129.5
1 4 0	142.8	140.7	138.8	143.1	147.0	143.9
1 6 0	161.5	162.6	163.0	164.9	160.8	162.9
1 8 0	179.5	183.2	178.4	181.1	177.5	187.7
2 0 0	199.7	202.7	203.1	202.3	207.7	205.2
2 2 5	221.8	228.4	222.4	222.2	229.3	236.4
2 5 0	247.7	241.7	243.7	242.4	244.2	253.9
2 8 0	281.6	274.7	273.4	279.1	274.6	272.7
3 1 5	306.2	301.3	303.8	297.4	315.4	319.8
3 5 5	348.0	342.6	340.7	342.4	354.7	343.6

SERIES F

EXACT RATIOS

9608

EXACT RATIOS - QUADRUPLE REDUCTION

NOMINAL RATIO	COLUMN ENTRY	F0640	F0740	F0840	F0940	F1040
	6 7 8					
360	3 6 0	348.1	368.5	344.7	358.5	361.0
400	4 0 0	404.8	393.5	401.0	412.2	420.3
450	4 5 0	440.1	447.0	439.5	457.6	447.8
500	5 0 0	516.1	501.6	511.2	525.8	521.3
560	5 6 0	561.0	569.8	566.7	590.0	577.1
630	6 3 0	634.0	643.3	605.0	667.4	651.3
710	7 1 0	714.4	699.4	722.5	753.2	715.9
800	8 0 0	785.0	820.1	771.4	851.8	808.4
900	9 0 0	853.4	891.6	808.7	855.0	891.3
1000	1 0 C	1001	974.3	940.5	982.8	1038
1100	1 1 C	1088	1059	1031	1091	1106
1200	1 2 C	1229	1242	1199	1254	1287
1400	1 4 C	1385	1350	1329	1407	1425
1600	1 6 C	1567	1526	1419	1591	1608
1800	1 8 C	1766	1719	1695	1796	1768
2000	2 0 C	1948	1945	1809	2031	1996
2200	2 2 C	2195	2192	2077	2200	2274
2500	2 5 C	2649	2418	2274	2410	2498
2800	2 8 C	2896	2724	2648	2809	2821
3200	3 2 C	3292	3287	3187	3075	3100
3600	3 6 C	3611	3594	3490	3431	3560
4000	4 0 C	4105	4086	3960	3758	3911
4500	4 5 C	4511	4539	4441	4281	4776
5000	5 0 C	4932	4962	4767	5189	5233
5600	5 6 C	5607	5642	5346	5765	6026

EXACT RATIOS - QUINTUPLE REDUCTION

NOMINAL RATIO	COLUMN ENTRY	F0650	F0750	F0850	F0950	F1050
	6 7 8					
4500	4 5 C	4400	4249			
5000	5 0 C	4889	4978			
5600	5 6 C	5609	5461			
6300	6 3 C	6232	6068	6539	6381	6469
7100	7 1 C	6971	6961	7390	6936	7032
8000	8 0 C	7746	7735	8326	7838	7947
9000	9 0 C	8602	8653	9420	8831	8954
10000	1 0 K	9776	9614	10614	9992	10131
11000	1 1 K	10692	10676	11708	11257	11413
12000	1 2 K	12151	12133	13192	12418	12590
14000	1 4 K	13331	13270	14004	13992	14186
16000	1 6 K	15151	15081	15920	16887	17121
18000	1 8 K	18210	18321	17406	18464	18720
20000	2 0 K	20695	20822	19788	20991	21282

NOMINAL RATIO ENTERED IN COLUMNS 6 7 8

SERIES F

MOUNTING POSITION

9702

COLUMN 13 ENTRY

MOUNTING POSITIONS

MOUNTING 1

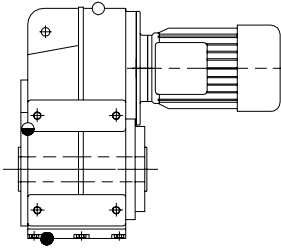

MOUNTING 2

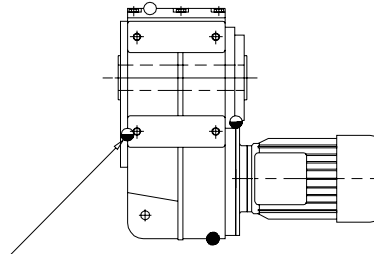

FOR F08, F09 & F10 UNITS FILL TO PLUG AT THIS SIDE OF CASE

MOUNTING 3

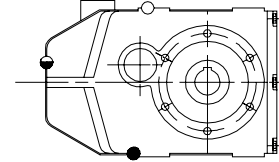

MOUNTING 4

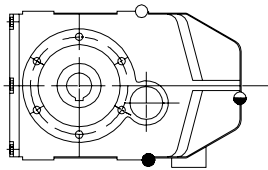

MOUNTING 5

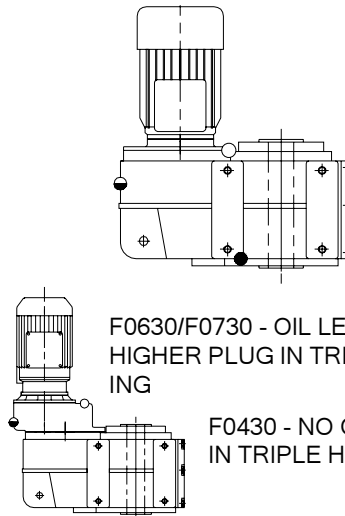

F0630/F0730 - OIL LEVELS TO HIGHER PLUG IN TRIPLE HOUSING

F0430 - NO OIL PLUGS IN TRIPLE HOUSING

MOUNTING 6

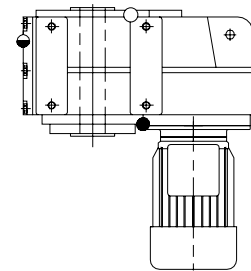

MOTOR MUST BE FITTED WITH SEAL FOR THIS POSITION

MOUNTING POSITIONS - SHOWN AS MOTORISED - APPLIES ALSO FOR REDUCERS
TERMINAL BOX SHOWN IN POSITION A - COLUMN 14 ENTRY

COLUMN 14 ENTRY

TERMINAL BOX POSITIONS

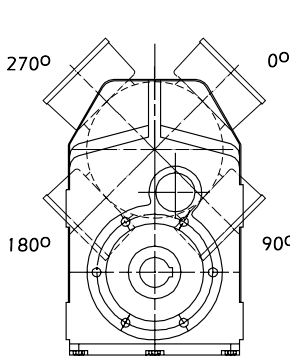

D63 MOTORS ONLY
(SIZES F0420, F0430, F0640, F0650, F0740, F0750, F0850, F0950 & F1050 ONLY)

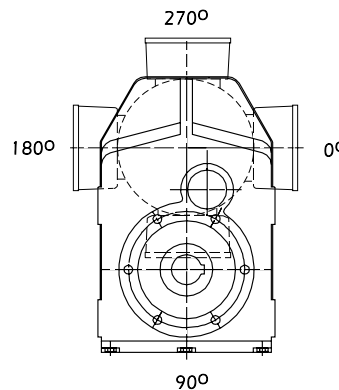

ALL MOTORS

- DRAIN POSITION
- LEVEL POSITION
- VENTILATOR/FILLING POSITION

Column 14 Entry	Terminal Box Position
A	0°
B	90°
C	180°
D	270°
-	Reducer or no motor fitted

SERIES F LUBRICATION

0101

The standard lubricant is suitable for operation in ambient temperatures of 0° to 30°C, outside of this consult either Table 2 or 3 or Textron Power Transmission Application Engineers.

TABLE 1 LUBRICANT QUANTITY (Litres)

DOUBLE AND TRIPLE REDUCTION													
Unit Size	F0420	F0430	F0620	F0630	F0720	F0730	F0820	F0830	F0920	F0930	F1020	F1030	
MOUNTING POSITION	1	1.7	2.0	4.7	4.8	8.0	8.2	10.9	10.9	19.0	18.0	34.0	34.0
	2	1.0	1.2	2.5	3.4	4.2	5.6	8.6	8.7	13.0	14.5	22.0	23.0
	3	1.4	1.8	3.9	4.7	7.0	7.7	10.0	9.4	17.0	16.0	28.0	28.0
	4	1.1	1.3	2.5	2.7	4.4	4.8	9.4	9.0	15.0	16.0	26.5	27.5
	5	1.8	2.6	3.9	6.5	7.0	11.9	14.0	14.0	24.0	24.0	43.0	43.0
	6	2.1	2.6	5.0	5.8	8.8	10.9	15.3	15.3	25.0	25.0	43.0	43.0

QUADRUPLE AND QUINTUPLE REDUCTION													
Unit Size	F0640		F0650		F0740		F0750		F0840		F0850		
	Primary	Secondary	Primary	Secondary	Primary	Secondary	Primary	Secondary	Primary	Secondary	Primary	Secondary	
	M0420	F0620	M0430	F0620	M0420	F0720	M0430	F0720	M0620	F0820	M0420	F0830	
MOUNTING POSITION	1	0.6	4.7	0.9	4.7	0.6	8.0	0.9	8.0	1.7	10.9	0.6	10.9
	2	0.6	2.5	0.9	2.5	0.6	4.2	0.9	4.2	1.7	8.6	0.6	8.7
	3	0.6	3.9	0.9	3.9	0.6	7.0	0.9	7.0	1.7	10.0	0.6	9.4
	4	0.6	2.5	0.9	2.5	0.6	4.4	0.9	4.4	1.7	9.4	0.6	9.0
	5	1.4	3.9	2.1	3.9	1.4	7.0	2.1	7.0	3.1	14.0	1.4	14.0
	6	1.6	5.0	2.1	5.0	1.6	8.8	2.1	8.8	3.6	15.3	1.6	15.3

QUADRUPLE AND QUINTUPLE REDUCTION									
Unit Size	F0940		F0950		F1040		F1050		
	Primary	Secondary	Primary	Secondary	Primary	Secondary	Primary	Secondary	
	M0720	F0920	M0420	F0930	M0820	F1020	M0420	F1030	
MOUNTING POSITION	1	2.8	19.0	0.6	18.0	4.6	34.0	0.6	34.0
	2	2.8	13.0	0.6	14.5	4.6	22.0	0.6	23.0
	3	2.8	17.0	0.6	16.0	4.6	28.0	0.6	28.0
	4	2.8	15.0	0.6	16.0	4.6	26.5	0.6	27.5
	5	6.3	24.0	1.4	24.0	9.5	43.0	1.4	43.0
	6	6.8	25.0	1.6	25.0	10.5	43.0	1.6	43.0

TABLE 2 MINERAL OILS

Type E - Mineral oils containing industrial EP additives. These have a high load carrying capacity

TEXTRON POWER TRANSMISSION GRADE NUMBERS	
6E	7E
AMBIENT TEMPERATURE RANGE °C	
0 to 30	20 to 50

TABLE 3 SYNTHETIC OILS

Type H - Polyalphaolefin based synthetic lubricants with Anti-Wear or EP additives. These have a medium to high load carrying capacity.

TEXTRON POWER TRANSMISSION GRADE NUMBERS		
5H	6H	7H
AMBIENT TEMPERATURE RANGE °C		
-30 to 10	-10 to 30	20 to 50

SERIES F

OUTPUT OPTIONS

9610

OUTPUTSHAFT OPTIONS, COLUMN 11 ENTRY

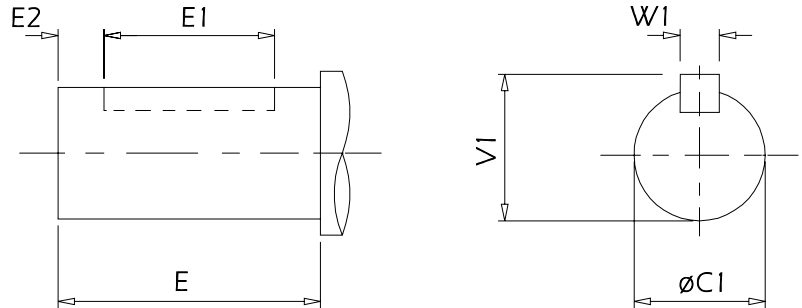

SIZE OF UNIT	TYPE OF OUTPUTSHAFT	COLUMN 11 ENTRY	DIMENSIONS IN MM (Inch shaft in inches)					
			øC1	E	E1	E2	V1	W1
F04	Standard Single Ext.	C	30.015/30.002	57	50	3	33	8
	Standard Double Ext.	D	29.993/29.980					
	Inch Single Ext.	N	1.0000"/0.9995"	1.811"	1.5625"	*	1.11"	0.25"
	Inch Double Ext.	P						
F06	Standard Single Ext.	C	35.018/35.002	66	58	3	38	10
	Standard Double Ext.	D	34.991/34.975					
	Inch Single Ext.	N	1.3750"/1.3745"	2.559"	2.1875"	*	1.52"	0.3125"
	Inch Double Ext.	P						
F07	Standard Single Ext.	C	50.018/50.002	86	80	3	53.5	14
	Standard Double Ext.	D	49.991/49.975					
	Inch Single Ext.	N	1.7500"/1.7490"	3.189"	2.875"	*	1.91"	0.375"
	Inch Double Ext.	P						
F08	Standard Single Ext.	C	60.030/60.011	114	100	3	64	18
	Standard Double Ext.	D	59.990/59.971					
	Inch Single Ext.	N	2.3750"/2.3740"	4.488"	3.6875"	*	2.65"	0.625"
	Inch Double Ext.	P	2.3746" / 2.3739"					
F09	Standard Single Ext.	C	70.030/70.011	135	110	3	74.5	20
	Standard Double Ext.	D	69.990/69.971					
	Inch Single Ext.	N	2.875"/2.874"	5.315"	4.625"	*	3.20"	0.750"
F10	Standard Single Ext.	C	90.035/90.013	172	140	5	95	25
	Inch Single Ext.	N	3.625"/3.624"	6.772"	5.9375"	*	4.01"	0.875"

* Inch shaft has an open ended keyway, therefore no 'E2' dimension is required

SERIES F

OUTPUT OPTIONS

9610

OUTPUT BORE OPTIONS, COLUMN 11 ENTRY

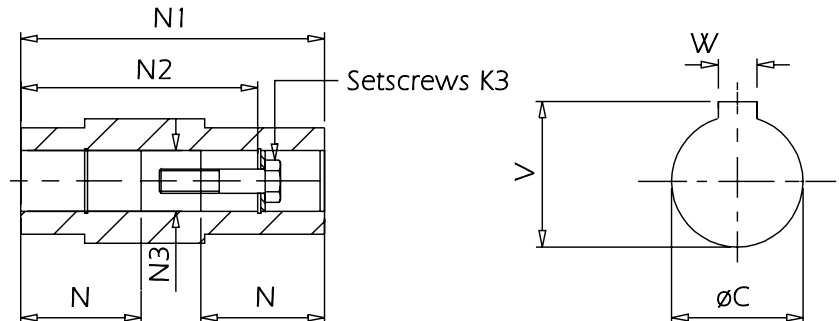

SIZE OF UNIT	TYPE OF BORE	COLUMN 11 ENTRY	DIMENSIONS IN MM (Inch bore in inches)							
			$\varnothing C$	K3	N	N1	N2	$\varnothing N3$	V	W
F04	Standard	H	30.021/30.000	M10x50L	67.5	150	122	30.2	33.5	8
	Inch	A	1.2510"/1.2500"	$\frac{7}{16}$ " - 20 UNF x 2" LONG	2.657"	5.906"	4.803"	1.260"	1.372"	0.25"
F06	Standard	H	40.025/40.000	M16x70L	90	200	156	40.2	43.5	12
	Inch	A	1.5010"/1.5000"	$\frac{5}{8}$ " - 8 UNF x $2\frac{3}{4}$ " LONG	3.543"	7.874"	6.142"	1.508"	1.674"	0.375"
F07	Standard	H	50.025/50.000	M16x70L	105	235	183	50.2	54.0	14
	Inch	A	2.0012"/2.0000"	$\frac{5}{8}$ " - 8 UNF x $2\frac{3}{4}$ " LONG	4.134"	9.252"	7.205"	2.008"	2.228"	0.5"
F08	Standard	H	60.030/60.000	M20x80L	117.5	265	210	60.2	64.5	18
	Inch	A	2.3762"/2.3750"	$\frac{3}{4}$ " - 16 UNF x $3\frac{1}{4}$ " LONG	4.626"	10.433"	8.268"	2.382"	2.656"	0.625"
F09	Standard	H	70.030/70.000	M20x80L	147.5	330	270	70.2	75	20
	Inch	A	2.7512"/2.7500"	$\frac{3}{4}$ " - 16 UNF x $3\frac{1}{4}$ " LONG	5.807"	12.992"	10.630"	2.764"	3.037"	0.625"
F10	Standard	H	80.030/80.000	M20x80L	165	370	313	80.2	85.5	22
	Inch	A	3.2514"/3.2500"	$\frac{3}{4}$ " - 16 UNF x $3\frac{1}{4}$ " LONG	6.496"	14.567"	12.323"	3.260"	3.591"	0.750"

SERIES F

MOTOR ADAPTORS

IEC & NEMA

9806

IEC MOTOR ADAPTORS, COLUMN 12 ENTRY FOR G TYPE ONLY

MOTOR FRAME / FLANGE	UNIT SIZE, NUMBER OF REDUCTIONS, REVISION NUMBER																								
	RATIO COVERAGE	F0420	F0430	F0620	F0630	F0640	F0650	F0720	F0730	F0740	F0750	F0820	F0830	F0840	F0850	F0920	F0930	F0940	F0950	F1020	F1030	F1040	F1050		
	5.0 - 25.	28. - 100	63. - 360	5.0 - 16.	18. - 100	63. - 90.	100 - 360	360 - 5600	4500 - 20000	5.0 - 16.	18. - 100	63 - 360	360 - 560	630 - 5600	4500 - 20000	5.0 - 25.	28. - 100	100 - 360	360 - 5600	6300 - 20000	5.0 - 25.	28. - 100	100 - 360	360 - 5600	6300 - 20000
63/D	-	F	F	-	V	-	F	F	F	-	-	V	-	F	F	-	-	-	V	F	-	-	-	-	F
71/D	-	G	G	-	D	-	G	G	G	-	-	D	-	G	G	-	-	-	D	G	-	-	-	-	G
71/C	-	H	H	-	E	-	H	H	H	-	-	E	-	H	H	-	-	-	E	H	-	-	-	-	H
80/D	A	J	J	W	F	A	J	J	J	-	F	F	A	J	J	-	D	F	F	J	-	E	L	F	J
80/C	B	K	K	X	G	B	K	K	K	-	G	G	B	K	K	-	-	G	G	K	-	-	-	G	K
90/D	C	Q	Q	Y	H	C	Q	Q	Q	-	H	H	C	Q	Q	-	E	H	H	Q	-	F	M	H	Q
90/C	D	R	R	Z	J	D	R	R	R	-	J	J	D	R	R	-	-	J	J	R	-	-	-	J	R
100/D	-	-	-	A	K	-	-	-	-	A	K	K	-	-	-	A	F	K	K	-	-	G	N	K	-
100/C	E	S	S	B	L	E	S	S	S	B	L	L	E	S	S	-	-	L	L	S	-	-	-	L	S
112/D	-	-	-	A	K	-	-	-	-	A	K	K	-	-	-	A	F	K	K	-	-	G	N	K	-
112/C	E	S	S	B	L	E	S	S	S	B	L	L	E	S	S	-	-	L	L	S	-	-	-	L	S
132/D	-	-	-	N	P	-	-	-	-	C	M	P	-	-	-	B	G	M	P	-	-	H	-	M	-
132/C	-	-	-	C	M	-	-	-	-	D	N	M	-	-	-	-	-	N	M	-	-	-	-	N	-
160/D	-	-	-	-	-	-	-	-	-	E	P	-	-	-	-	C	H	P	-	-	A	J	-	P	-
180/D	-	-	-	-	-	-	-	-	-	-	-	-	-	-	-	-	-	-	-	-	B	K	-	-	B
200/D	-	-	-	-	-	-	-	-	-	-	-	-	-	-	-	-	-	-	-	-	C	L	-	-	C
225/D	-	-	-	-	-	-	-	-	-	-	-	-	-	-	-	-	-	-	-	-	D	M	-	-	D

BOLD - IF UNITS SUPPLIED AS GEARHEAD ONLY THEY WILL BE SUPPLIED LESS LUBRICANT

NEMA MOTOR ADAPTORS, COLUMN 12 ENTRY FOR A TYPE ONLY

MOTOR FRAME / FLANGE	UNIT SIZE, NUMBER OF REDUCTIONS, REVISION NUMBER																								
	RATIO COVERAGE	F0420	F0430	F0620	F0630	F0640	F0650	F0720	F0730	F0740	F0750	F0820	F0830	F0840	F0850	F0920	F0930	F0940	F0950	F1020	F1030	F1040	F1050		
	5.0 - 25.	28. - 100	63. - 360	5.0 - 16.	18. - 100	63. - 90.	100 - 360	360 - 5600	4500 - 20000	5.0 - 16.	18. - 100	63 - 360	360 - 560	630 - 5600	4500 - 20000	5.0 - 25.	28. - 100	100 - 360	360 - 5600	6300 - 20000	5.0 - 25.	28. - 100	100 - 360	360 - 5600	6300 - 20000
56C	T	U	U	-	Q	T	U	U	U	-	Q	Q	T	U	U	-	M	Q	Q	U	-	-	X	Q	U
143TC/ 145TC	V	W	W	-	R	V	W	W	W	-	R	R	V	W	W	-	N	R	R	W	-	-	Y	R	W
182TC/ 184TC	X	-	-	S	T	X	-	-	-	S	T	T	X	-	-	J	P	T	T	-	-	S	Z	T	-
213TC/ 215TC	-	-	-	U	-	-	-	-	-	U	V	-	-	-	-	K	Q	V	-	-	-	T	-	V	-
254TC/ 256TC	-	-	-	-	-	-	-	-	-	W	-	-	-	-	-	L	U	-	-	-	P	U	-	-	L
284TC/ 286TC	-	-	-	-	-	-	-	-	-	-	-	-	-	-	-	-	-	-	-	-	Q	V	-	-	M
324TC/ 326TC	-	-	-	-	-	-	-	-	-	-	-	-	-	-	-	-	-	-	-	-	R	W	-	-	N

SERIES F

ADDITIONAL FEATURES

0004

ADDITIONAL FEATURES - COLUMN 20 ENTRY

Column 20 Entry	Double Oil Seals	Prime Painted Only	Motorised Backstop	Lubricant Type * (See lubrication details - Page 10)	
				Mineral	Synthetic
- (1)				●	
A	●			●	
B		●		●	
C	●	●		●	
D (2)					
E	●				
F		●			
G	●	●			
H					●
J	●				●
K		●			●
L	●	●			●
M			●	●	
N	●		●	●	
P		●	●	●	
Q	●	●	●	●	
R			●		
S	●		●		
T		●	●		
U	●	●	●		
V			●		●
W	●		●		●
X		●	●		●
Y	●	●	●		●

* Customer requests for special oils must be referred to Textron Power Transmission Applications Engineering, since a derate could result depending on oil type used.

(1) Standard option sizes F04, F06 and F07

(2) Standard option sizes F08, F09 and F10

SERIES F

CONE RING FLEXIBLE COUPLINGS

0004

This type of coupling compensates for normal angular and parallel misalignment of shafts, together with a limited freedom of axial movement. The conical section rubber rings provide greatly improved torsional flexibility in drives where shock or cyclic loadings are present.

Two types are available, MEDIUM DUTY and HEAVY DUTY. Medium duty couplings (types 612 and 614) are identical to heavy duty couplings (types 611 and 613) except that they are supplied with only half the standard number of pin and ring assemblies. This enables a useful cost saving to be made when the size of coupling is determined by the shaft diameter rather than the coupling's torque capacity.

Parallel Keyway to BS 4235 : Part 1 1972 (1986) with P9 width tolerance

Bore tolerance to ISO 286-2-1988(E) is M7 upto and incl. 50 mm
K7 over 50 mm

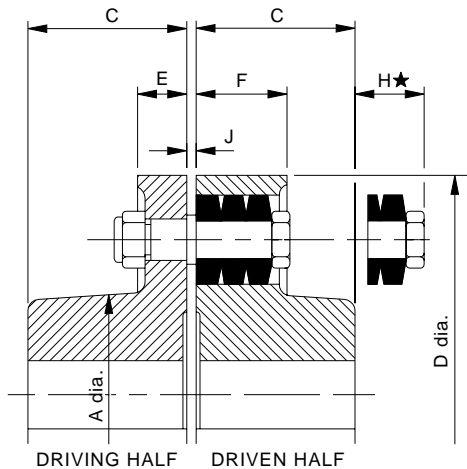

Coupling Size	A	D	E	F	H	H★	J
01	64	134	12	26	20	28	3
02	70	147	12	26	12	23	3
03	83	171	19	35	26	37	3
04	97	193	19	35	19	37	3
05	117	215	19	35	11	37	3
06	127	254	31	56	46	59	3
07	147	279	31	56	34	52	3
08	180	330	30	61	22	41	3
09	206	371	46	81	45	53	6
10	230	419	46	81	30	41	6
11	256	457	46	81	12	-	6
12	296	533	46	81	0	-	6

★ The coupling pin withdrawal distance is dimension H for straight bored couplings or dimension H★ for taper bushed couplings.

Reference number	Bore diameter	Reference number	Bore diameter
---	Pilot	063	63
018	18	065	65
019	19	070	70
020	20	071	71
022	22	075	75
024	24	080	80
025	25	085	85
028	28	090	90
030	30	095	95
032	32	100	100
035	35	110	110
038	38	115	115
040	40	120	120
042	42	125	125
045	45	130	130
048	48	140	140
050	50	150	150
055	55	160	160
056	56	170	170
060	60		

Coupling size	Types 611 & 612 Straight bored			Types 613 & 614 Taper bushed				Types 612 & 614 Medium Duty				Types 611 & 613 Heavy Duty			
	Max. bore	Min. bore		Hub length C	Max. bore	Min. bore	Hub length C	Taper bush length	Torque kNm	kW 100 rev/min	kW 960 rev/min	kW 1450 rev/min	Torque kNm	kW 100 rev/min	Max rev/min
Driving half	Driven half	Driving half	Driven half												
01	38	*	19	48	25	9	40	22.3	0.090	0.95	9.1	13.7	0.181	1.89	4780
02	42	*	22	56	32	11	45	38.1	0.140	1.46	14.0	21.2	0.279	2.92	4335
03	48	*	25	61	40	14	50	38.1	0.232	2.43	23.4	35.3	0.465	4.87	3745
04	60	*	28	68	48	18	50	44.5	0.359	3.75	36.0	54.4	0.717	7.51	3320
05	70	*	32	76	60	16	50	44.5	0.509	5.33	51.2	77.3	1.018	10.7	3000
06	80	25	42	88	60	19	75	63.5	1.219	12.76	123	185	2.438	25.5	2520
07	90	30	55	100	75	35	82	76.2	1.681	17.60	169	255	3.362	35.2	2295
08	100	40	60	117	90	35	98	88.9	2.524	26.42	254	383	5.047	52.8	1940
09	120	50	65	132	110	55	124	114.3	4.217	44.15	424	640	8.433	88.3	1725
10	140	80	80	147	125	70	136	127	5.765	60.37	580	875	11.53	120.7	1530
11	150	90	90	165	-	-	-	-	7.530	78.85	757	-	15.06	157.7	1400
12	170	100	100	188	-	-	-	-	11.750	123.00	1181	-	23.50	246.1	1200

* Note: up to size 05 the Driving half hubs are solid.

All dimensions in mm

For applications in ambient temperatures above 80°C (176°F) or below -30°C (-22°F) refer to Textron Power Transmission.

The depths of rectangular Imperial keyways to BS46 are generally greater than the equivalent metric keyways, hence the maximum bores given must be marginally reduced when using an Imperial inch system. Consult Textron Power Transmission for details.

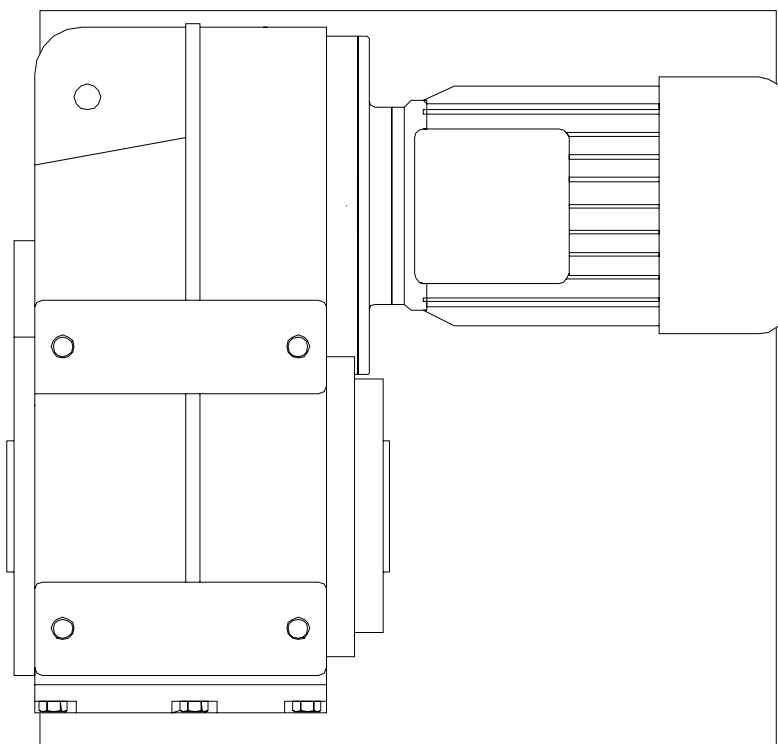

MOTORISED SERIES F

SERIES F

MOTOR PERFORMANCE DATA ALUMINIUM FRAME MOTORS

9607

Type Cage Rotor
 Enclosure IP55, TEFV (ICO141)
 Rating S1 (Maximum Continuous)
 Supply 3 PH 50Hz 380 - 415V
 Insulation Class F
 Temp. Rise Class B

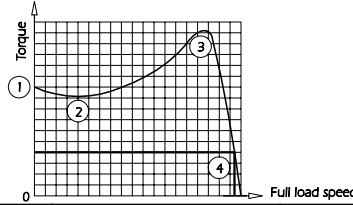

Typical Speed/Torque Curve (D.O.L. Starting)

- (1) Starting Torque or Locked Rotor Torque
- (2) Pull Up Torque or Run Up Torque
- (3) Pull Out Torque or Breakdown Torque
- (4) Full Load Torque

Torque/Speed curves for specific motors can be supplied on request

kW	MOTOR FRAME SIZE	FULL LOAD SPEED	FLC (AMPS) 400 VOLTS	EFFICIENCY %			POWER FACTOR			D.O.L. STARTING % OF FULL LOAD		STAR DELTA STARTING % OF FULL LOAD		PULL UP TORQUE % FLT	PULL OUT TORQUE % FLT	ROTOR INERTIA WK ² IN KG M ²
				FL	3/4 L	1/2 L	FL	3/4 L	1/2 L	LRT	LRC	LRT	LRC			
0.12	63	1360	0.5	55	50	43	0.65	0.60	0.50	260	320			240	260	0.00025
	63	835	0.6	43	41	37	0.62	0.56	0.46	230	250			200	180	0.0003
	71	600	0.7	42	38	34	0.56	0.50	0.42	200	250			180	180	0.0006
0.18	63	2680	0.54	61	58	52	0.79	0.73	0.60	250	380			210	210	0.0002
	63	1360	0.7	56	52	44	0.67	0.60	0.50	260	320			240	260	0.0003
	71	840	0.8	52.5	51	47	0.62	0.55	0.47	230	260			200	180	0.0005
	80	650	0.8	53	49	45	0.61	0.56	0.45	180	230			160	180	0.0024
0.25	63	2730	0.7	64	61	55	0.80	0.72	0.60	240	400			210	210	0.00023
	71	1370	0.8	64	60	54	0.68	0.63	0.56	270	370			240	260	0.0005
	71	845	1.1	53	52.5	50	0.62	0.55	0.47	240	280			200	180	0.0006
	80	650	1.0	55.5	52	46	0.68	0.60	0.50	180	250			160	180	0.00275
0.37	71	2730	1.05	65	62	58	0.79	0.72	0.60	280	400			250	250	0.0004
	71	1380	1.2	65	64	58	0.67	0.60	0.52	280	420			260	270	0.0006
	80	925	1.2	62	59	50	0.72	0.62	0.52	220	340			170	200	0.0024
	90	680	1.4	62	59	53	0.62	0.54	0.44	260	380			220	230	0.00375
0.55	71	2720	1.5	68	66	62	0.80	0.73	0.63	280	420			260	250	0.00045
	80	1370	1.6	67.5	68	65	0.74	0.64	0.52	250	400			180	200	0.0013
	80	925	1.65	67	62	53	0.72	0.62	0.52	250	370			200	210	0.00275
	90	690	2.05	63	60	54	0.62	0.54	0.44	320	420			270	280	0.005
0.75	80	2800	1.9	71	69	67	0.83	0.78	0.66	230	460			190	230	0.00083
	80	1385	2.2	70	69	66	0.72	0.62	0.51	250	430			190	200	0.0016
	90	910	2.2	67	65	63	0.75	0.66	0.55	240	360			190	240	0.00375
	100	700	2.4	68	68	66	0.68	0.58	0.48	160	440			110	170	0.0093
1.1	80	2840	2.5	76	75	73	0.83	0.75	0.64	250	540			190	240	0.00097
	90	1380	2.9	72	72.5	72	0.76	0.68	0.57	250	440			220	250	0.0033
	90	920	3.1	71	68	64	0.73	0.67	0.52	240	460			140	290	0.005
	100	700	3.4	69	68	66	0.68	0.58	0.48	200	440			140	180	0.0123
1.5	90	2820	3.5	76	75	74	0.82	0.73	0.63	240	500			200	250	0.0016
	90	1390	3.8	76	76	75	0.76	0.66	0.55	260	500			230	260	0.004
	100	950	3.9	75	74.5	73	0.75	0.66	0.54	180	500			150	200	0.01
	112	700	4.3	72	72	70	0.71	0.62	0.52	180	430			170	200	0.017
2.2	90	2850	5.0	78	78	77	0.82	0.73	0.63	300	700			260	320	0.0022
	100	1410	5.2	78.5	78.5	78	0.78	0.71	0.60	240	530			210	240	0.0073
	112	945	5.5	75	76	76	0.77	0.71	0.57	220	500			190	200	0.015
	132	705	5.8	74	74	73.5	0.74	0.64	0.53	180	500			130	160	0.038
3	100	2900	6.5	79	79	77	0.84	0.74	0.64	270	700			250	300	0.005
	100	1420	6.8	80	80	79	0.80	0.72	0.60	240	550			210	250	0.009
	132	950	7.1	78	78	77	0.78	0.71	0.60	190	600			150	200	0.03
	132	710	7.6	76.5	77	76	0.75	0.68	0.56	180	430			130	160	0.046
4	112	2900	8.2	83	83	82	0.85	0.81	0.73	280	700	85	220	260	300	0.0063
	112	1425	8.6	83	83	82	0.81	0.72	0.62	270	620	84	195	230	290	0.0115
	132	955	9.5	78	78	77	0.78	0.72	0.62	230	600	73	190	160	230	0.038
	160	720	9.5	81	81.5	80.5	0.74	0.67	0.55	180	430	60	140	150	210	0.08
5.5	132	2900	11.8	83	82.5	80	0.82	0.75	0.64	340	700	100	220	280	280	0.016
	132	1450	11.85	85	85.5	85	0.79	0.72	0.59	260	650	80	200	180	270	0.0238
	132	960	13	81	80	79	0.76	0.66	0.54	260	660	80	210	180	260	0.046
	160	720	13.5	81	81.5	81	0.75	0.70	0.58	180	430	60	140	150	210	0.092
7.5	132	2900	15.3	84.5	84	81	0.84	0.79	0.73	330	700	100	220	270	270	0.019
	132	1450	15.6	86	86	85	0.81	0.75	0.64	260	690	80	215	180	270	0.03
	160	965	15	86	86	86.5	0.82	0.78	0.69	200	530	65	175	160	230	0.087
	160	720	17	84	84	83	0.75	0.70	0.58	200	470	65	155	180	220	0.11
9.2	132	2910	18.5	85	85	83	0.85	0.81	0.73	340	720	105	220	270	270	0.023
	132	1460	18.5	88	88	87	0.82	0.75	0.65	260	740	81	230	180	270	0.0338
11	132	2920	22	89	89	88	0.82	0.77	0.68	210	620	70	200	200	270	0.03
	160	1460	22.5	88	88	87	0.81	0.76	0.65	210	520	70	160	180	220	0.0625
	160	970	22.5	86.5	87	87	0.82	0.75	0.64	230	600	75	200	200	250	0.11
	180	720	24.5	86	86	84	0.75	0.69	0.57	220	500	73	165	190	230	0.16

SERIES F

MOTOR PERFORMANCE DATA ALUMINIUM FRAME MOTORS

9607

kW	MOTOR FRAME SIZE	FULL LOAD SPEED	FLC (AMPS) 400 VOLTS	EFFICIENCY %			POWER FACTOR			D.O.L. STARTING % OF FULL LOAD		STAR DELTA STARTING % OF FULL LOAD		PULL UP TORQUE % FLT	PULL OUT TORQUE % FLT	ROTOR INERTIA WK ² IN KGM ²
				FL	3/4 L	1/2 L	FL	3/4 L	1/2L	LRT	LRC	LRT	LRC			
15	160	2930	29	90	90	89	0.83	0.79	0.7	280	650	90	215	240	320	0.035
	160	1460	30	89	89	89	0.81	0.76	0.64	230	590	75	195	190	240	0.075
	180	970	30	88	88	87.5	0.82	0.78	0.69	230	570	75	190	180	230	0.13
	200	725	33	86	86	84	0.75	0.68	0.55	220	500	70	165	190	230	0.22
18.5	160	2940	36	90	89	88	0.83	0.8	0.71	290	710	95	235	280	330	0.04
	180	1460	36.5	89	89	89	0.82	0.76	0.65	240	620	80	200	190	250	0.09
	200	970	36.5	88	88	87.5	0.83	0.79	0.7	230	540	75	180	190	230	0.17
	225	725	39.5	88	88	87	0.77	0.73	0.65	240	500	80	165	160	240	0.42
22	180	2940	41	90	90	89.5	0.86	0.83	0.76	280	710	90	235	230	350	0.048
	180	1465	42	89.5	89.5	89	0.85	0.8	0.69	240	620	80	200	200	260	0.11
	200	970	43	89	89	88.5	0.84	0.79	0.69	240	570	80	190	190	250	0.22
	225	725	47	89	88.5	88	0.76	0.69	0.59	250	550	80	180	190	260	0.52
30	200	2940	55	90.5	90	90	0.87	0.85	0.78	280	680	90	225	210	320	0.165
	200	1465	57	90	90	90	0.85	0.8	0.7	240	650	80	215	200	280	0.18
	225	975	58	90.5	91	90	0.82	0.78	0.69	260	620	85	200	200	260	0.47
37	200	2950	67	91.5	91.5	91	0.87	0.84	0.77	280	710	90	235	250	330	0.18
	225	1470	67	91.5	91.5	91	0.86	0.82	0.71	230	650	75	215	200	270	0.32
45	225	2960	80	92.3	92	91	0.88	0.86	0.79	250	660	80	220	220	330	0.225
	225	1470	83	91.5	92	91.5	0.86	0.82	0.73	230	650	75	215	210	280	0.41

All variants of standard IEC and NEMA motors can be fitted to Series F, For example:-

- Single phase
- DC
- Energy efficient
- Wash down
- Explosion-proof
- Suitable to be used with inverters
- Force vented
- Flame proof
- Two speed
- Tropicalised
- Crane duty
- Underground specification
- Fitted with encoders
- Fitted with tacho
- Fitted with thermistors
- Fitted with anti condensation heaters
- Hydraulic motors with IEC flanges
- Air motors with IEC flanges

Standard clutch brake modules with IEC flanges can be fitted between motor and gearhead.

Variable speed packages are available, either belt variators or mechanical disc variators.

For any of these combinations please contact your local Textron Power Transmission Sales office.

SERIES F

BRAKE MOTORS

MOTORS AVAILABLE

9502

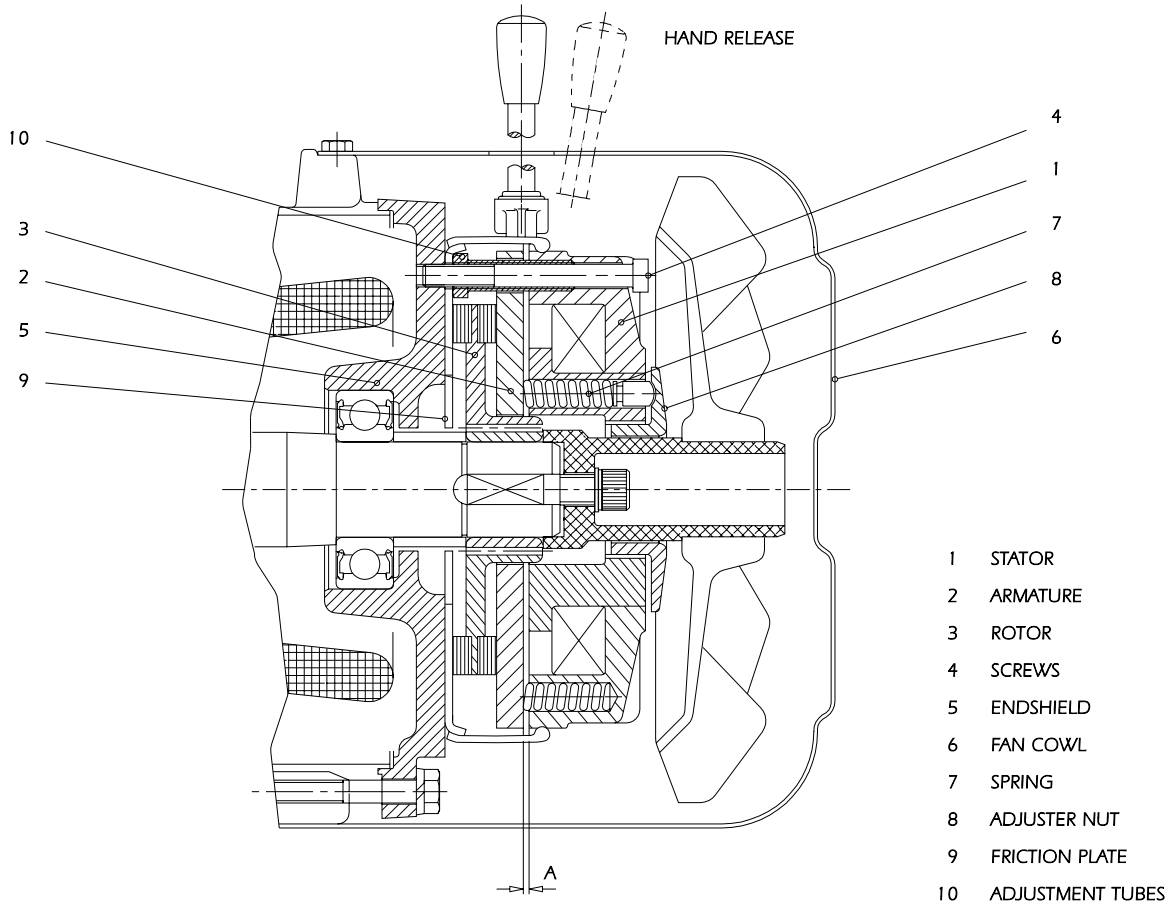

BRAKE MOTORS

Brake motors are fitted with spring-loaded brakes (mounted between motor endshield and fan blade) under the fan cowl. When the motor is switched on, the brake is supplied with DC voltage via a suitable rectifier.

The spring-loaded brake is normally off, electromagnetically released brake comprising the stator (1), the armature (2) and the brake rotor (3). It is fixed to the motor endshield (5) with screws (4) and located under the fan cowl (6). The friction plate (9) is held against the motor end shield (5) and serves as a counter friction face. When the release current does not flow the springs (7) press the armature (2) against the brake rotor (3) which in turn is pressed against the friction plate (9). The braking torque is generated through friction on both friction faces.

When switching on the motor the brake release coil is activated and the magnetic force of the stator (1) releases armature (2) against the spring resistance (7). The rotor (3) is freed.

The brake torque can be reduced by a maximum of 40% by using an adjuster (8).

We recommend to check the air gap A periodically, although, normally the brake needs no maintenance. Depending on the inertia to brake, speed, and switching frequency, the rotor can wear and become smaller due to the friction at the friction surfaces. If A max. (see table) is attained, the air gap must be adjusted. Where adjustment is needed, slacken screws (4) and reset the gap by turning adjustment tubes (10). Re-tighten screws (4) to the correct torque shown in the table below.

MOTOR FRAME SIZE		63	71	80	90	100/112	132
BRAKE SIZE		06	06	08	10	12	14
BRAKE TORQUE	Nm	2.85	4	8	16	32	60
A	mm	0.2	0.2	0.2	0.2	0.3	0.3
A max	mm	0.5	0.5	0.5	0.5	0.75	0.8
BOLT TIGHTENING TORQUE		Nm	3	3	6	10	25

MOTORS AVAILABLE
COLUMN 19 ENTRY

TYPE OF MOTOR	COLUMN 19 ENTRY
STANDARD	A
STANDARD WITH BRAKE	B *
STANDARD WITH BRAKE & HAND RELEASE	C
FIT NON STANDARD MOTOR	N
FIT FREE ISSUE MOTOR	F

* The standard motor with brake will be fitted with a rectifier and wired for AC switching.

For fast braking needed with safety critical applications (ie lifts, hoists and cranes), it is essential to switch the brake on the DC side of the rectifier.

In such cases motor type N should be entered in column 19.

For larger frame sizes standard proprietary brake motors are available. For details contact Textron Power Transmission

SERIES F

MOTOR DETAILS

9706

B14 'C' FACE

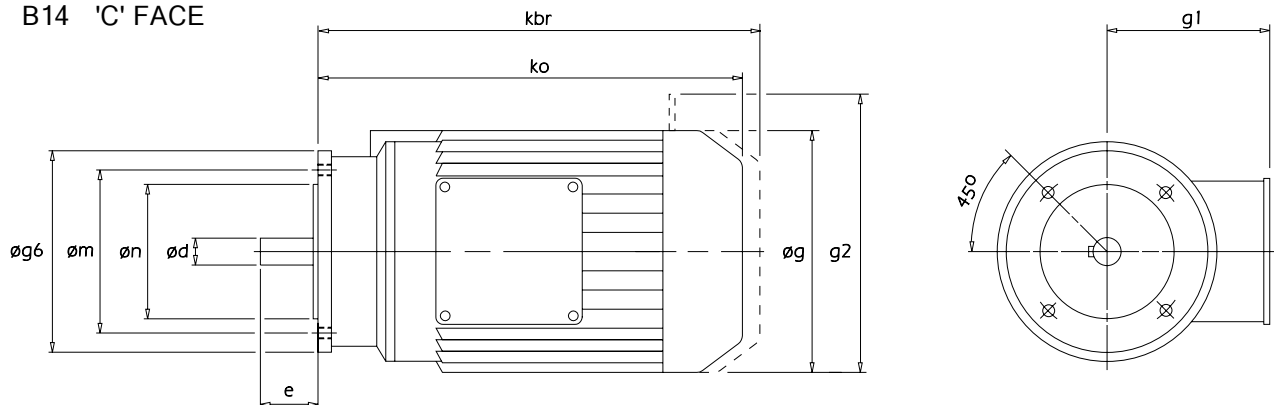

MOTOR FRAME SIZE	øg6	øm	øn	ød	e	ko	kbr	øg	g1	g2	FIXING BOLTS
71	105	85	70	14	30	210	251	137	107	167	4-M6
80	120	100	80	19	40	230	280	158	118	190	4-M6
90S/L	140	115	95	24	50	270	329	177	149	218	4-M8
100	160	130	110	28	60	340	408	197	159	238	4-M8
112	160	130	110	28	60	340	408	197	159	238	4-M8
132S/M	200	165	130	38	80	402	473	253	184	288	4-M10

B5 'D' FLANGE

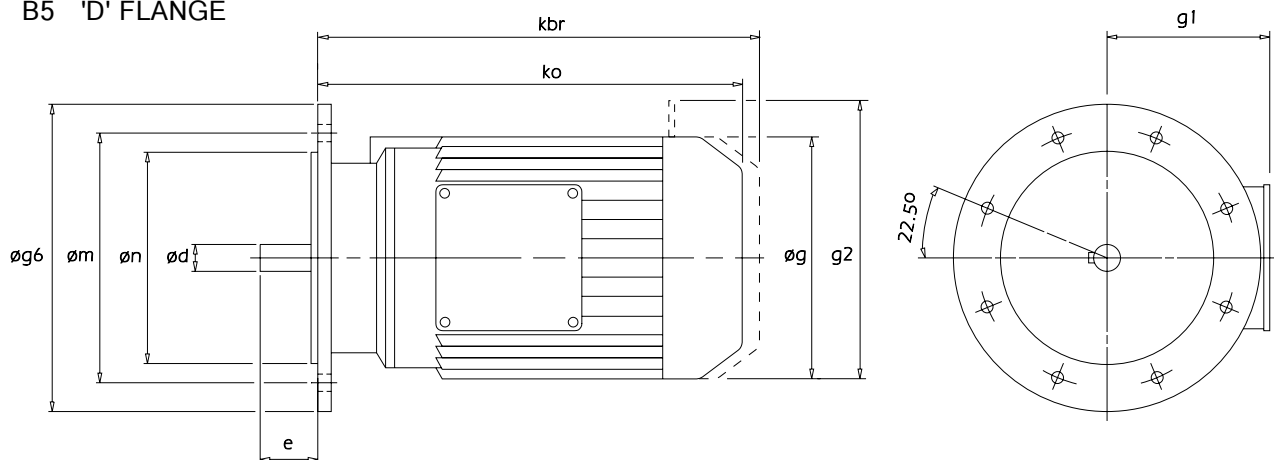

MOTOR FRAME SIZE	øg6	øm	øn	ød	e	ko	kbr	øg	g1	g2	FIXING BOLTS
63	140	115	95	11	23	185	227	122	101	160	4-M8
71	160	130	110	14	30	210	251	137	107	167	4-M8
80	200	165	130	19	40	230	280	158	118	190	4-M10
90S/L	200	165	130	24	50	270	329	177	149	218	4-M10
100	250	215	180	28	60	340	408	197	159	238	4-M12
112	250	215	180	28	60	340	408	197	159	238	4-M12
132S/M	300	265	230	38	80	402	473	253	184	288	4-M12
160M/L	350	300	250	42	110	538	627*	314	230	397*	4-M16
180M	350	300	250	48	110	538	663*	314	257	452*	4-M16
180L	350	300	250	48	110	613	701*	354	257	452*	4-M16
200L	400	350	300	55	110	613	807*	354	257	549*	4-M16
225S/M	450	400	350	60	140	690	1105*	411	280	561*	8-M16

* Maximum dimension

These dimensions apply to standard Textron Power Transmission motors

SERIES F

SELECTION TABLES

GEARED MOTORS

9608

0.12 kW	N2 R/MIN	i	M2 Nm	Fm	N	UNIT DESIGNATION	Kg	SERIES X	MM	
4 POLE	Output Speed	Ratio	Output Torque	Service Factor	Overhung Load	Column Entry 1 Through 20 Spaces to be filled when entering order	Weight of Base Mount Unit	Motor Frame Size	Cone Ring Output Coupling Spaces to be filled when entering order	Max Bore Coupling Driven Half
	47	28.82	23	11.88	7610	F 0 4 2 0 2 8 . _ M _ - _ _ . 1 2 4 A _	25.5	63a	X 6 1 1 0 3 M 0 3 0 - _ _ _	48
	43	31.33	25	11.18	7670	3 2 .				
	38	35.62	29	11.88	7670	3 6 .				
	35	38.72	31	11.18	7670	4 0 .				
	30	45.14	36	7.97	7670	4 5 .				
	27	50.86	41	7.22	7670	5 0 .				
	24	55.79	45	7.97	7670	5 6 .				
	22	62.86	51	7.22	7670	6 3 .				
	20	67.10	54	4.88	7670	7 1 .			X 6 1 1 0 2 M 0 3 0 - _ _ _	42
	18	76.29	61	4.06	7670	8 0 .				
	16	82.94	67	4.88	7670	9 0 .			X 6 1 1 0 3 M 0 3 0 - _ _ _	48
	14	94.29	76	4.06	7670	1 0 0				
	21	63.92	51	7.34	7670	F 0 4 3 0 6 3 . _ M _ - _ _ . 1 2 4 A _	28.5	63a	X 6 1 1 0 3 M 0 3 0 - _ _ _	48
	19	73.05	58	6.42	7670	7 1 .				
	17	79.00	63	6.07	7670	8 0 .				
	15	90.28	72	5.31	7670	9 0 .				
	14	98.59	79	4.77	7670	1 0 0				
	12	115.51	92	4.07	7670	1 1 2				
	11	121.85	97	3.94	7670	1 2 5				
	10	142.76	114	3.37	7660	1 4 0				
	8.4	161.54	129	2.92	7660	1 6 0				
	7.6	179.49	143	2.63	7650	1 8 0				
	6.8	199.65	159	2.42	7640	2 0 0				
	6.1	221.84	177	2.18	7640	2 2 5				
	5.5	247.74	198	1.78	7630	2 5 0				
	4.8	281.55	225	1.52	7620	2 8 0				
	4.4	306.20	244	1.59	7610	3 1 5				
	3.9	347.99	277	1.40	7530	3 5 5				
	5.0	274.74	220	3.78	14900	F 0 6 3 0 2 8 0 _ M _ - _ _ . 1 2 4 A _	54.5	63a	X 6 1 1 0 5 M 0 4 5 - _ _ _	70
	4.5	301.33	242	3.33	14900	3 1 5				
	4.0	342.56	274	2.94	14900	3 5 5				
	3.9	348.08	276	2.71	14803	F 0 6 4 0 3 6 0 _ M _ - _ _ . 1 2 4 A _	62.5	63a	X 6 1 1 0 5 M 0 4 5 - _ _ _	70
	3.4	404.84	321	2.51	14803	4 0 0				
	3.1	440.13	349	2.31	14803	4 5 0				
	2.6	516.06	408	1.97	14803	5 0 0				
	2.4	561.05	443	1.82	14803	5 6 0				
	2.1	634.05	501	1.61	14803	6 3 0				
	1.9	714.42	563	1.43	14803	7 1 0				
	1.7	784.98	620	1.35	14567	8 0 0				
	1.6	853.42	673	1.24	14567	9 0 0				
	1.4	1000.64	787	1.06	14567	1 0 C				
	1.3	1087.88	855	0.98	14567	1 1 C				
	1.1	1229.42	967	0.87	14567	1 2 C				
	2.1	643.35	508	3.38	18581	F 0 7 4 0 6 3 0 _ M _ - _ _ . 1 2 4 A _	104.5	63a	X 6 1 1 0 6 M 0 5 0 - _ _ _	80
	1.9	699.44	552	3.11	18581	7 1 0				
	1.7	820.10	646	2.66	18581	8 0 0				
	1.5	891.60	702	2.45	18581	9 0 0				
	1.4	974.27	767	2.24	18581	1 0 C				
	1.3	1059.22	833	2.06	18581	1 1 C				
	1.1	1241.93	974	1.77	18581	1 2 C				
	1.0	1350.21	1059	1.63	18581	1 4 C				
	.89	1525.89	1196	1.44	18581	1 6 C				
	.79	1719.31	1346	1.28	18581	1 8 C				
	.70	1945.08	1520	1.13	18581	2 0 C				
	.62	2191.65	1710	1.01	18581	2 2 C				
	.56	2417.64	1883	0.91	18581	2 5 C				
	.50	2724.10	2119	0.81	18581	2 8 C				
	1.8	771.40	608	3.86	20998	F 0 8 4 0 8 0 0 _ M _ - _ _ . 1 2 4 A _	147.5	63a	X 6 1 1 0 6 M 0 6 0 - _ _ _	80
	1.4	940.55	740	3.77	19052	1 0 C			X 6 1 1 0 7 M 0 6 0 - _ _ _	90
	1.3	1031.06	808	3.45	19052	1 1 C				
	1.1	1199.20	940	2.97	19052	1 2 C				
	1.0	1329.24	1044	2.67	19052	1 4 C				
	.96	1419.22	1115	2.50	19052	1 6 C				
	.80	1694.78	1327	2.10	19052	1 8 C				
	.75	1809.50	1416	1.97	19052	2 0 C				
	.65	2076.72	1628	1.71	19052	2 2 C				
	.60	2273.97	1781	1.56	19052	2 5 C				
	.51	2647.82	2068	1.35	19052	2 8 C				
	.43	3187.19	2481	1.12	19052	3 2 C				
	.39	3489.91	2715	1.03	19052	3 6 C				
	.34	3960.34	3082	0.90	19052	4 0 C				
	.31	4441.50	3451	0.81	19052	4 5 C			X 6 1 1 0 8 M 0 6 0 - _ _ _	100

NOTE

Other output speeds are available using 2 and 8 pole motors - Consult Textron Power Transmission

SERIES F

SELECTION TABLES

GEARED MOTORS

9608

0.12 kW		N2 R/MIN	i	M2 Nm	Fm	N	UNIT DESIGNATION	Kg	SERIES X	MM
6 POLE	Output Speed	Ratio	Output Torque	Service Factor	Overhung Load	Column Entry 1 Through 20	Weight of Base Mount Unit	Motor Frame Size	Cone Ring Output Coupling Spaces to be filled when entering order	Max Bore Coupling Driven Half
	Spaces to be filled when entering order									
	29	28.82	38	7.39	7670	F 0 4 2 0 2 8 . _ M _ - _ _ . 1 2 6 A _	25.9	63b	X 6 1 1 0 3 M 0 3 0 - _ _ _	48
	27	31.33	41	7.32	7670	3 2 .				
	23	35.62	47	7.39	7670	3 6 .				
	22	38.72	51	7.32	7670	4 0 .				
	18	45.14	59	5.40	7670	4 5 .				
	16	50.86	67	4.44	7670	5 0 .				
	15	55.79	73	5.23	7670	5 6 .				
	13	62.86	83	4.44	7670	6 3 .				
	12	67.10	88	3.10	7670	7 1 .			X 6 1 1 0 2 M 0 3 0 - _ _ _	42
	11	76.29	100	2.49	7670	8 0 .				
	10	82.94	109	3.10	7670	9 0 .			X 6 1 1 0 3 M 0 3 0 - _ _ _	48
	8.9	94.29	124	2.49	7660	1 0 0				
	13	63.92	83	4.50	7670	F 0 4 3 0 6 3 . _ M _ - _ _ . 1 2 6 A _	28.9	63b	X 6 1 1 0 3 M 0 3 0 - _ _ _	48
	11	73.05	95	3.94	7670	7 1 .				
	11	79.00	103	3.73	7670	8 0 .				
	9.2	90.28	118	3.26	7670	9 0 .				
	8.5	98.59	129	2.93	7660	1 0 0				
	7.2	115.51	151	2.50	7660	1 1 2				
	6.9	121.85	159	2.42	7650	1 2 5				
	5.8	142.76	186	2.07	7640	1 4 0				
	5.2	161.54	211	1.79	7630	1 6 0				
	4.7	179.49	233	1.62	7620	1 8 0				
	4.2	199.65	261	1.49	7610	2 0 0				
	3.8	221.84	289	1.34	7600	2 2 5				
	3.4	247.74	322	1.09	7290	2 5 0				
	3.0	281.55	365	0.94	6970	2 8 0				
	2.7	306.20	399	0.97	6810	3 1 5				
	2.4	347.99	453	0.86	6430	3 5 5				
	11	75.79	100	3.79	14900	F 0 6 2 0 8 0 . _ M _ - _ _ . 1 2 6 A _	49.9	63b	X 6 1 1 0 3 M 0 4 5 - _ _ _	48
	8.8	94.50	124	3.79	14900	1 0 0			X 6 1 1 0 4 M 0 4 5 - _ _ _	60
	5.1	162.55	213	3.86	14900	F 0 6 3 0 1 6 0 _ M _ - _ _ . 1 2 6 A _	54.9	63b	X 6 1 1 0 5 M 0 4 5 - _ _ _	70
	4.6	183.16	240	3.47	14900	1 8 0				
	4.1	202.68	265	3.04	14900	2 0 0				
	3.7	228.38	298	2.70	14900	2 2 5				
	3.5	241.67	317	2.72	14900	2 5 0				
	3.0	274.74	360	2.43	14900	2 8 0				
	2.8	301.33	394	2.04	14900	3 1 5				
	2.4	342.56	446	1.80	14900	3 5 5				
	2.4	348.08	449	1.67	14803	F 0 6 4 0 3 6 0 _ M _ - _ _ . 1 2 6 A _	62.9	63b	X 6 1 1 0 5 M 0 4 5 - _ _ _	70
	2.1	404.84	522	1.54	14803	4 0 0				
	1.9	440.13	567	1.42	14803	4 5 0				
	1.6	516.06	663	1.22	14803	5 0 0				
	1.5	561.05	720	1.12	14803	5 6 0				
	1.3	634.05	814	0.99	14803	6 3 0				
	1.2	714.42	915	0.88	14803	7 1 0				
	1.1	784.98	1006	0.83	14567	8 0 0				
	3.1	273.36	356	3.79	19700	F 0 7 3 0 2 8 0 _ M _ - _ _ . 1 2 6 A _	87.9	63b	X 6 1 1 0 6 M 0 5 0 - _ _ _	80
	2.5	340.69	443	3.79	19700	3 5 5				
	1.3	643.35	827	2.08	18581	F 0 7 4 0 6 3 0 _ M _ - _ _ . 1 2 6 A _	104.9	63b	X 6 1 1 0 6 M 0 5 0 - _ _ _	80
	1.2	699.44	898	1.91	18581	7 1 0				
	1.0	820.10	1050	1.64	18581	8 0 0				
	.94	891.60	1141	1.51	18581	9 0 0				
	.86	974.27	1246	1.38	18581	1 0 C				
	.79	1059.22	1354	1.27	18581	1 1 C				
	.67	1241.93	1583	1.09	18581	1 2 C				
	.62	1350.21	1720	1.00	18581	1 4 C				
	.55	1525.89	1945	0.88	18581	1 6 C				
	1.6	511.23	656	3.58	20998	F 0 8 4 0 5 0 0 _ M _ - _ _ . 1 2 6 A _	147.9	63b	X 6 1 1 0 6 M 0 6 0 - _ _ _	80
	1.5	566.66	729	3.22	20998	5 6 0				
	1.4	605.02	778	3.02	20998	6 3 0				
	1.2	722.49	926	2.54	20998	7 1 0				
	1.1	771.40	988	2.38	20998	8 0 0				
	1.0	808.68	1032	2.70	19052	9 0 0			X 6 1 1 0 7 M 0 6 0 - _ _ _	90
	.89	940.55	1200	2.32	19052	1 0 C				
	.81	1031.06	1309	2.13	19052	1 1 C				
	.70	1199.20	1523	1.83	19052	1 2 C				
	.63	1329.24	1695	1.64	19052	1 4 C				
	.59	1419.22	1810	1.54	19052	1 6 C				
	.49	1694.78	2152	1.30	19052	1 8 C				
	.46	1809.50	2297	1.21	19052	2 0 C				
	.40	2076.72	2643	1.05	19052	2 2 C				
	.37	2273.97	2892	0.96	19052	2 5 C				
	.32	2647.82	3355	0.83	19052	2 8 C				

NOTE
Other output speeds are available using 2 and 8 pole motors - Consult Textron Power Transmission

SERIES F

SELECTION TABLES

GEARED MOTORS

9608

0.18 kW	N2 R/MIN	i	M2 Nm	Fm	N	UNIT DESIGNATION	Kg	SERIES X	MM	
4 POLE	Output Speed	Ratio	Output Torque	Service Factor	Overhung Load	Column Entry 1 Through 20 Spaces to be filled when entering order	Weight of Base Mount Unit	Motor Frame Size	Cone Ring Output Coupling Spaces to be filled when entering order	Max Bore Coupling Driven Half
	47	28.82	35	7.92	7516	F 0 4 2 0 2 8 . _ M _ - _ _ . 1 8 4 A _	25.9	63b	X 6 1 1 0 3 M 0 3 0 - _ _ _	48
	43	31.33	38	7.45	7574					
	38	35.62	43	7.92	7578					
	35	38.72	47	7.45	7577					
	30	45.14	55	5.31	7591					
	27	50.86	61	4.81	7592					
	24	55.79	68	5.31	7595					
	22	62.86	76	4.81	7571					
	20	67.10	81	3.25	7603					
	18	76.29	92	2.70	7568			X 6 1 1 0 2 M 0 3 0 - _ _ _	42	
	16	82.94	100	3.25	7550			X 6 1 1 0 3 M 0 3 0 - _ _ _	48	
	14	94.29	114	2.70	7572					
	21	63.92	77	4.89	7562	F 0 4 3 0 6 3 . _ M _ - _ _ . 1 8 4 A _	28.9	63b	X 6 1 1 0 3 M 0 3 0 - _ _ _	48
	19	73.05	88	4.28	7582					
	17	79.00	95	4.04	7568					
	15	90.28	108	3.54	7526					
	14	98.59	118	3.18	7547					
	12	115.51	139	2.71	7477					
	11	121.85	146	2.63	7464					
	10	142.76	171	2.25	7373					
	8.4	161.54	193	1.95	7381					
	7.6	179.49	215	1.76	7290					
	6.8	199.65	239	1.61	7212					
	6.1	221.84	266	1.45	7112					
	5.5	247.74	297	1.19	7057					
	4.8	281.55	338	1.01	6849					
	4.4	306.20	366	1.06	6742					
	7.4	183.16	221	3.67	14852	F 0 6 3 0 1 8 0 _ M _ - _ _ . 1 8 4 A _	54.9	63b	X 6 1 1 0 5 M 0 4 5 - _ _ _	70
	6.7	202.68	244	3.30	14833					
	6.0	228.38	274	2.93	14757					
	5.6	241.67	292	2.81	14858					
	5.0	274.74	331	2.52	14746					
	4.5	301.33	363	2.22	14718					
	4.0	342.56	411	1.96	14876					
	3.9	348.08	414	1.80	14803	F 0 6 4 0 3 6 0 _ M _ - _ _ . 1 8 4 A _	62.9	63b	X 6 1 1 0 5 M 0 4 5 - _ _ _	70
	3.4	404.84	482	1.67	14803					
	3.1	440.13	523	1.54	14803					
	2.6	516.06	612	1.32	14803					
	2.4	561.05	665	1.21	14803					
	2.1	634.05	751	1.07	14803					
	1.9	714.42	845	0.95	14803					
	1.7	784.98	930	0.90	14567					
	1.6	853.42	1010	0.83	14567					
	2.1	643.35	763	2.26	18581	F 0 7 4 0 6 3 0 _ M _ - _ _ . 1 8 4 A _	104.9	63b	X 6 1 1 0 6 M 0 5 0 - _ _ _	80
	1.9	699.44	829	2.08	18581					
	1.7	820.10	969	1.77	18581					
	1.5	891.60	1053	1.63	18581					
	1.4	974.27	1150	1.50	18581					
	1.3	1059.22	1250	1.38	18581					
	1.1	1241.93	1462	1.18	18581					
	1.0	1350.21	1588	1.08	18581					
	.89	1525.89	1794	0.96	18581					
	.79	1719.31	2019	0.85	18581					
	2.7	511.23	606	3.87	20998	F 0 8 4 0 5 0 0 _ M _ - _ _ . 1 8 4 A _	147.9	63b	X 6 1 1 0 6 M 0 6 0 - _ _ _	80
	2.4	566.66	673	3.49	20998					
	2.2	605.02	718	3.27	20998					
	1.9	722.49	855	2.75	20998					
	1.8	771.40	913	2.57	20998					
	1.7	808.68	954	2.92	19052					
	1.4	940.55	1110	2.51	19052			X 6 1 1 0 7 M 0 6 0 - _ _ _	90	
	1.3	1031.06	1212	2.30	19052					
	1.1	1199.20	1410	1.98	19052					
	1.0	1329.24	1567	1.78	19052					
	.96	1419.22	1673	1.67	19052					
	.80	1694.78	1991	1.40	19052					
	.75	1809.50	2125	1.31	19052					
	.65	2076.72	2442	1.14	19052					
	.60	2273.97	2672	1.04	19052					
	.51	2647.82	3102	0.90	19052					

NOTE
Other output speeds are available using 2 and 8 pole motors - Consult Textron Power Transmission

SERIES F

SELECTION TABLES

GEARED MOTORS

9608

0.18 kW	N2 R/MIN	i	M2 Nm	Fm	N	UNIT DESIGNATION	Kg	SERIES X	MM	
6 POLE	Output Speed	Ratio	Output Torque	Service Factor	Overhung Load	Column Entry 1 Through 20 Spaces to be filled when entering order	Weight of Base Mount Unit	Motor Frame Size	Cone Ring Output Coupling Spaces to be filled when entering order	Max Bore Coupling Driven Half
	29	28.82	56	4.96	7589	F 0 4 2 0 2 8 . _ M _ - _ _ . 1 8 6 A _	27.8	71a	X 6 1 1 0 3 M 0 3 0 - _ _ _	48
	27	31.33	61	4.91	7591	3 2 .				
	24	35.62	70	4.96	7597	3 6 .				
	22	38.72	76	4.91	7585	4 0 .				
	19	45.14	89	3.62	7598	4 5 .				
	17	50.86	100	2.98	7565	5 0 .				
	15	55.79	110	3.50	7545	5 6 .				
	13	62.86	123	2.98	7506	6 3 .				
	13	67.10	132	2.08	7531	7 1 .			X 6 1 1 0 2 M 0 3 0 - _ _ _	42
	11	76.29	150	1.67	7474	8 0 .				
	10	82.94	163	2.08	7446	9 0 .			X 6 1 1 0 3 M 0 3 0 - _ _ _	48
	8.9	94.29	185	1.67	7482	1 0 0				
	13	63.92	125	3.02	7491	F 0 4 3 0 6 3 . _ M _ - _ _ . 1 8 6 A _	30.8	71a	X 6 1 1 0 3 M 0 3 0 - _ _ _	48
	11	73.05	142	2.64	7496	7 1 .				
	11	79.00	154	2.50	7474	8 0 .				
	9.3	90.28	176	2.19	7406	9 0 .				
	8.5	98.59	192	1.96	7439	1 0 0				
	7.3	115.51	225	1.68	7319	1 1 2				
	6.9	121.85	237	1.62	7290	1 2 5				
	5.9	142.76	278	1.39	7136	1 4 0				
	5.2	161.54	314	1.20	7076	1 6 0				
	4.7	179.49	348	1.08	6909	1 8 0				
	4.2	199.65	389	1.00	6765	2 0 0				
	3.8	221.84	431	0.90	6561	2 2 5				
	12	67.58	133	4.00	14900	F 0 6 2 0 7 1 . _ M _ - _ _ . 1 8 6 A _	51.8	71a	X 6 1 1 0 4 M 0 4 5 - _ _ _	60
	11	75.79	149	2.54	14900	8 0 .			X 6 1 1 0 3 M 0 4 5 - _ _ _	48
	10	84.26	166	4.00	14890	9 0 .			X 6 1 1 0 4 M 0 4 5 - _ _ _	60
	8.9	94.50	186	2.54	14900	1 0 0				
	8.1	103.79	203	3.98	14777	F 0 6 3 0 1 0 0 _ M _ - _ _ . 1 8 6 A _	56.8	71a	X 6 1 1 0 5 M 0 4 5 - _ _ _	70
	7.4	112.84	221	3.66	14890	1 1 2				
	6.5	129.41	253	3.18	14852	1 2 5				
	6.0	140.70	275	2.92	14804	1 4 0				
	5.2	162.55	318	2.59	14844	1 6 0				
	4.6	183.16	358	2.33	14746	1 8 0				
	4.1	202.68	395	2.04	14704	2 0 0				
	3.7	228.38	445	1.81	14876	2 2 5				
	3.5	241.67	472	1.82	14804	2 5 0				
	3.1	274.74	537	1.63	14612	2 8 0				
	2.8	301.33	587	1.37	14564	3 1 5				
	2.5	342.56	665	1.21	14853	3 5 5				
	2.4	348.08	669	1.12	14803	F 0 6 4 0 3 6 0 _ M _ - _ _ . 1 8 6 A _	64.8	71a	X 6 1 1 0 5 M 0 4 5 - _ _ _	70
	2.1	404.84	778	1.03	14803	4 0 0				
	1.9	440.13	846	0.95	14803	4 5 0				
	1.6	516.06	988	0.82	14803	5 0 0				
	3.8	222.40	433	3.88	19442	F 0 7 3 0 2 2 5 _ M _ - _ _ . 1 8 6 A _	89.8	71a	X 6 1 1 0 6 M 0 5 0 - _ _ _	80
	3.4	243.74	474	3.41	19547	2 5 0				
	3.1	273.36	531	2.54	19676	2 8 0				
	2.8	303.78	590	2.91	19676	3 1 5				
	2.5	340.69	660	2.54	19700	3 5 5				
	1.3	643.35	1233	1.40	18581	F 0 7 4 0 6 3 0 _ M _ - _ _ . 1 8 6 A _	106.8	71a	X 6 1 1 0 6 M 0 5 0 - _ _ _	80
	1.2	699.44	1340	1.28	18581	7 1 0				
	1.0	820.10	1567	1.10	18581	8 0 0				
	.94	891.60	1702	1.01	18581	9 0 0				
	.86	974.27	1859	0.93	18581	1 0 C				
	.79	1059.22	2020	0.85	18581	1 1 C				
	2.4	344.74	663	3.54	20998	F 0 8 4 0 3 6 0 _ M _ - _ _ . 1 8 6 A _	149.8	71a	X 6 1 1 0 6 M 0 6 0 - _ _ _	80
	2.1	400.96	770	3.05	20998	4 0 0				
	1.9	439.55	842	2.79	20998	4 5 0				
	1.6	511.23	978	2.40	20998	5 0 0				
	1.5	566.66	1087	2.16	20998	5 6 0				
	1.4	605.02	1160	2.02	20998	6 3 0				
	1.2	722.49	1380	1.70	20998	7 1 0				
	1.1	771.40	1473	1.59	20998	8 0 0				
	1.0	808.68	1539	1.81	19052	9 0 0			X 6 1 1 0 7 M 0 6 0 - _ _ _	90
	.89	940.55	1790	1.56	19052	1 0 C				
	.81	1031.06	1953	1.43	19052	1 1 C				
	.70	1199.20	2271	1.23	19052	1 2 C				
	.63	1329.24	2528	1.10	19052	1 4 C				
	.59	1419.22	2698	1.03	19052	1 6 C				
	.50	1694.78	3208	0.87	19052	1 8 C				
	.46	1809.50	3425	0.81	19052	2 0 C			X 6 1 1 0 8 M 0 6 0 - _ _ _	100

NOTE
Other output speeds are available using 2 and 8 pole motors - Consult Textron Power Transmission

SERIES F

SELECTION TABLES

GEARED MOTORS

9608

	N2 R/MIN	i	M2 Nm	Fm	N	UNIT DESIGNATION	Kg	SERIES X	MM	
0.25 kW	Output Speed	Ratio	Output Torque	Service Factor	Overhung Load	Column Entry 1 Through 20 Spaces to be filled when entering order	Weight of Base Mount Unit	Cone Ring Output Coupling Spaces to be filled when entering order	Max Bore Coupling Driven Half	
4 POLE	48	28.82	48	5.74	7407	F 0 4 2 0 2 8 . _ M _ - _ _ . 2 5 4 A _	27.3	71a	X 6 1 1 0 3 M 0 3 0 - _ _ _	48
	44	31.33	52	5.40	7463	3 2 .				
	38	35.62	60	5.74	7471	3 6 .				
	35	38.72	65	5.40	7470	4 0 .				
	30	45.14	76	3.85	7498	4 5 .				
	27	50.86	85	3.49	7502	5 0 .				
	25	55.79	94	3.85	7509	5 6 .				
	22	62.86	105	3.49	7456	6 3 .				
	20	67.10	112	2.36	7525	7 1 .			X 6 1 1 0 2 M 0 3 0 - _ _ _	42
	18	76.29	127	1.96	7449	8 0 .				
	17	82.94	139	2.36	7412	9 0 .			X 6 1 1 0 3 M 0 3 0 - _ _ _	48
	15	94.29	158	1.96	7458	1 0 0				
	21	63.92	106	3.55	7437	F 0 4 3 0 6 3 . _ M _ - _ _ . 2 5 4 A _	30.3	71a	X 6 1 1 0 3 M 0 3 0 - _ _ _	48
	19	73.05	121	3.11	7480	7 1 .				
	17	79.00	131	2.93	7449	8 0 .				
	15	90.28	150	2.57	7358	9 0 .				
	14	98.59	163	2.31	7403	1 0 0				
	12	115.51	191	1.97	7252	1 1 2				
	11	121.85	202	1.90	7225	1 2 5				
	10	142.76	236	1.63	7040	1 4 0				
	8.5	161.54	267	1.41	7056	1 6 0				
	7.6	179.49	296	1.27	6870	1 8 0				
	6.9	199.65	330	1.17	6714	2 0 0				
	6.2	221.84	367	1.05	6496	2 2 5				
	5.5	247.74	409	0.86	6390	2 5 0				
	18	75.79	127	2.99	14890	F 0 6 2 0 8 0 . _ M _ - _ _ . 2 5 4 A _	51.3	71a	X 6 1 1 0 3 M 0 4 5 - _ _ _ X 6 1 1 0 4 M 0 4 5 - _ _ _	48 60
	14	94.50	158	2.99	14900	1 0 0				
	11	129.41	215	3.73	14846	F 0 6 3 0 1 2 5 . _ M _ - _ _ . 2 5 4 A _	56.3	71a	X 6 1 1 0 5 M 0 4 5 - _ _ _	70
	10	140.70	234	3.44	14780	1 4 0				
	8.4	162.55	270	2.99	14608	1 6 0				
	7.5	183.16	305	2.66	14796	1 8 0				
	6.8	202.68	336	2.39	14755	2 0 0				
	6.0	228.38	378	2.13	14590	2 2 5				
	5.7	241.67	402	2.04	14809	2 5 0				
	5.0	274.74	456	1.83	14567	2 8 0				
	4.5	301.33	500	1.61	14506	3 1 5				
	4.0	342.56	567	1.42	14848	3 5 5				
	3.9	348.08	571	1.31	14803	F 0 6 4 0 3 6 0 _ M _ - _ _ . 2 5 4 A _	64.3	71a	X 6 1 1 0 5 M 0 4 5 - _ _ _	70
	3.4	404.84	664	1.21	14803	4 0 0				
	3.1	440.13	722	1.12	14803	4 5 0				
2.7	516.06	844	0.95	14803	5 0 0					
2.4	561.05	917	0.88	14803	5 6 0					
5.6	243.74	403	3.67	19527	F 0 7 3 0 2 5 0 _ M _ - _ _ . 2 5 4 A _	89.3	71a	X 6 1 1 0 6 M 0 5 0 - _ _ _	80	
5.0	273.36	452	2.99	19381	2 8 0					
4.5	303.78	502	3.42	19302	3 1 5					
4.0	340.69	562	2.99	19596	3 5 5					
2.1	643.35	1052	1.64	18581	F 0 7 4 0 6 3 0 _ M _ - _ _ . 2 5 4 A _	106.3	71a	X 6 1 1 0 6 M 0 5 0 - _ _ _	80	
2.0	699.44	1143	1.51	18581	7 1 0					
1.7	820.10	1337	1.29	18581	8 0 0					
1.5	891.60	1452	1.18	18581	9 0 0					
1.4	974.27	1586	1.08	18581	1 0 C					
1.3	1059.22	1724	1.00	18581	1 1 C					
1.1	1241.93	2016	0.85	18581	1 2 C					
3.4	400.96	658	3.57	20998	F 0 8 4 0 4 0 0 _ M _ - _ _ . 2 5 4 A _	149.3	71a	X 6 1 1 0 6 M 0 6 0 - _ _ _	80	
3.1	439.55	719	3.27	20998	4 5 0					
2.7	511.23	836	2.81	20998	5 0 0					
2.4	566.66	928	2.53	20998	5 6 0					
2.3	605.02	990	2.37	20998	6 3 0					
1.9	722.49	1179	1.99	20998	7 1 0					
1.8	771.40	1258	1.87	20998	8 0 0					
1.7	808.68	1316	2.12	19052	9 0 0			X 6 1 1 0 7 M 0 6 0 - _ _ _	90	
1.5	940.55	1530	1.82	19052	1 0 C					
1.3	1031.06	1672	1.67	19052	1 1 C					
1.1	1199.20	1944	1.43	19052	1 2 C					
1.0	1329.24	2161	1.29	19052	1 4 C					
.97	1419.22	2306	1.21	19052	1 6 C					
.81	1694.78	2745	1.02	19052	1 8 C					
.76	1809.50	2930	0.95	19052	2 0 C					
.66	2076.72	3367	0.83	19052	2 2 C			X 6 1 1 0 8 M 0 6 0 - _ _ _	100	

NOTE
Other output speeds are available using 2 and 8 pole motors - Consult Textron Power Transmission

SERIES F

SELECTION TABLES

GEARED MOTORS

9608

0.25 kW	N2 R/MIN	i	M2 Nm	Fm	N	UNIT DESIGNATION	Kg		SERIES X	MM
6 POLE	Output Speed	Ratio	Output Torque	Service Factor	Overhung Load	Column Entry 1 Through 20 Spaces to be filled when entering order	Weight of Base Mount Unit	Motor Frame Size	Cone Ring Output Coupling Spaces to be filled when entering order	Max Bore Coupling Driven Half
	29	28.82	78	3.59	7496	F 0 4 2 0 2 8 . _ M _ - _ _ . 2 5 6 A _	28.3	71b	X 6 1 1 0 3 M 0 3 0 - _ _ _	48
	27	31.33	85	3.56	7498					
	24	35.62	96	3.59	7513					
	22	38.72	105	3.56	7486					
	19	45.14	123	2.62	7515					
	17	50.86	138	2.16	7443					
	15	55.79	152	2.54	7399					
	13	62.86	170	2.16	7315					
	13	67.10	182	1.51	7370				X 6 1 1 0 2 M 0 3 0 - _ _ _	42
	11	76.29	207	1.21	7246					
	10	82.94	225	1.51	7186				X 6 1 1 0 3 M 0 3 0 - _ _ _	48
	9.0	94.29	255	1.21	7275					
	13	63.92	172	2.19	7284	F 0 4 3 0 6 3 . _ M _ - _ _ . 2 5 6 A _	31.3	71b	X 6 1 1 0 3 M 0 3 0 - _ _ _	48
	12	73.05	197	1.92	7295					
	11	79.00	213	1.81	7246					
	9.4	90.28	243	1.58	7098					
	8.6	98.59	265	1.42	7181					
	7.3	115.51	311	1.21	6921					
	6.9	121.85	328	1.18	6870					
	5.9	142.76	384	1.00	6548					
	5.2	161.54	434	0.87	6430					
	13	67.58	184	2.89	14900	F 0 6 2 0 7 1 . _ M _ - _ _ . 2 5 6 A _	52.3	71b	X 6 1 1 0 4 M 0 4 5 - _ _ _ X 6 1 1 0 3 M 0 4 5 - _ _ _ X 6 1 1 0 4 M 0 4 5 - _ _ _	60 48 60
	11	75.79	206	1.84	14900					
	10	84.26	229	2.89	14879					
	8.9	94.50	256	1.84	14900					
	8.1	103.79	281	2.88	14634	F 0 6 3 0 1 0 0 _ M _ - _ _ . 2 5 6 A _	57.3	71b	X 6 1 1 0 5 M 0 4 5 - _ _ _	70
	7.5	112.84	305	2.65	14879					
	6.5	129.41	350	2.30	14796					
	6.0	140.70	380	2.12	14693					
	5.2	162.55	439	1.87	14779					
	4.6	183.16	495	1.69	14567					
	4.2	202.68	546	1.48	14476					
	3.7	228.38	615	1.31	14848					
	3.5	241.67	652	1.32	14692					
	3.1	274.74	741	1.18	14276					
	2.8	301.33	811	0.99	14172					
	2.5	342.56	919	0.88	14800					
	2.4	348.08	925	0.81	14803	F 0 6 4 0 3 6 0 _ M _ - _ _ . 2 5 6 A _	65.3	71b	X 6 1 1 0 5 M 0 4 5 - _ _ _	70
	5.2	162.96	439	3.59	19501	F 0 7 3 0 1 6 0 _ M _ - _ _ . 2 5 6 A _	90.3	71b	X 6 1 1 0 6 M 0 5 0 - _ _ _	80
	4.7	178.44	481	3.32	19394					
	4.2	203.11	546	3.07	19288					
	3.8	222.40	597	2.81	19142					
	3.5	243.74	655	2.47	19369					
	3.1	273.36	733	1.84	19648					
	2.8	303.78	815	2.11	19648					
	2.5	340.69	912	1.84	19700					
	1.3	643.35	1703	1.01	18581	F 0 7 4 0 6 3 0 _ M _ - _ _ . 2 5 6 A _	107.3	71b	X 6 1 1 0 6 M 0 5 0 - _ _ _	80
	1.2	699.44	1850	0.93	18581					
	2.5	344.74	915	2.57	20998	F 0 8 4 0 3 6 0 _ M _ - _ _ . 2 5 6 A _	150.3	71b	X 6 1 1 0 6 M 0 6 0 - _ _ _	80
	2.1	400.96	1064	2.21	20998					
	1.9	439.55	1162	2.02	20998					
	1.7	511.23	1351	1.74	20998					
	1.5	566.66	1501	1.57	20998					
	1.4	605.02	1602	1.47	20998					
	1.2	722.49	1906	1.23	20998					
	1.1	771.40	2034	1.15	20998					
	1.0	808.68	2125	1.31	19052					
	.90	940.55	2471	1.13	19052				X 6 1 1 0 7 M 0 6 0 - _ _ _	90
	.82	1031.06	2696	1.03	19052					
	.70	1199.20	3136	0.89	19052					

NOTE
Other output speeds are available using 2 and 8 pole motors - Consult Textron Power Transmission

SERIES F

SELECTION TABLES

GEARED MOTORS

9608

0.37 kW	N2 R/MIN	i	M2 Nm	Fm	N	UNIT DESIGNATION	Kg	SERIES X	MM	
4 POLE	Output Speed	Ratio	Output Torque	Service Factor	Overhung Load	Column Entry 1 Through 20 Spaces to be filled when entering order	Weight of Base Mount Unit	Motor Frame Size	Cone Ring Output Coupling Spaces to be filled when entering order	Max Bore Coupling Driven Half
	48	28.82	71	3.91	7220	F 0 4 2 0 2 8 . . M _ - 3 7 4 A _	28.0	71b	X 6 1 1 0 3 M 0 3 0 - _ _ _	48
	44	31.33	77	3.68	7273	3 2 .				
	39	35.62	88	3.91	7287	3 6 .				
	36	38.72	95	3.68	7285	4 0 .				
	31	45.14	112	2.62	7340	4 5 .				
	27	50.86	125	2.38	7348	5 0 .				
	25	55.79	138	2.62	7361	5 6 .				
	22	62.86	155	2.38	7259	6 3 .				
	21	67.10	165	1.61	7392	7 1 .			X 6 1 1 0 2 M 0 3 0 - _ _ _	42
	18	76.29	188	1.33	7245	8 0 .				
	17	82.94	204	1.61	7173	9 0 .			X 6 1 1 0 3 M 0 3 0 - _ _ _	48
	15	94.29	232	1.33	7263	1 0 0				
	22	63.92	156	2.42	7223	F 0 4 3 0 6 3 . . M _ - 3 7 4 A _	31.0	71b	X 6 1 1 0 3 M 0 3 0 - _ _ _	48
	19	73.05	178	2.11	7304	7 1 .				
	17	79.00	193	2.00	7245	8 0 .				
	15	90.28	220	1.75	7070	9 0 .				
	14	98.59	240	1.57	7158	1 0 0				
	12	115.51	282	1.34	6867	1 1 2				
	11	121.85	297	1.30	6815	1 2 5				
	10	142.76	348	1.11	6468	1 4 0				
	8.5	161.54	392	0.96	6500	1 6 0				
	7.7	179.49	436	0.87	6150	1 8 0				
	20	67.58	167	3.19	14881	F 0 6 2 0 7 1 . . M _ - 3 7 4 A _	52.0	71b	X 6 1 1 0 4 M 0 4 5 - _ _ _	60
	18	75.79	187	2.03	14881	8 0 .			X 6 1 1 0 3 M 0 4 5 - _ _ _	48
	16	84.26	208	3.19	14881	9 0 .			X 6 1 1 0 4 M 0 4 5 - _ _ _	60
	15	94.50	232	2.03	14900	1 0 0				
	13	103.79	254	3.19	14664	F 0 6 3 0 1 0 0 _ M _ - 3 7 4 A _	57.0	71b	X 6 1 1 0 5 M 0 4 5 - _ _ _	70
	12	112.84	276	2.93	14874	1 1 2				
	11	129.41	317	2.54	14797	1 2 5				
	10	140.70	344	2.34	14670	1 4 0				
	8.5	162.55	398	2.04	14338	1 6 0				
	7.5	183.16	448	1.81	14701	1 8 0				
	6.8	202.68	495	1.63	14622	2 0 0				
	6.0	228.38	556	1.45	14304	2 2 5				
	5.7	241.67	591	1.39	14725	2 5 0				
	5.0	274.74	671	1.24	14260	2 8 0				
	4.6	301.33	735	1.10	14144	3 1 5				
	4.0	342.56	833	0.97	14800	3 5 5				
	4.0	348.08	840	0.89	14803	F 0 6 4 0 3 6 0 _ M _ - 3 7 4 A _	65.0	71b	X 6 1 1 0 5 M 0 4 5 - _ _ _	70
	3.4	404.84	976	0.83	14803	4 0 0				
	8.5	162.96	399	3.63	19591	F 0 7 3 0 1 6 0 _ M _ - 3 7 4 A _	90.0	71b	X 6 1 1 0 6 M 0 5 0 - _ _ _	80
	7.7	178.44	436	3.34	19464	1 8 0				
	6.8	203.11	494	3.40	19319	2 0 0				
	6.2	222.40	539	3.11	19156	2 2 5				
	5.7	243.74	593	2.50	19368	2 5 0				
	5.0	273.36	664	2.03	19087	2 8 0				
	4.5	303.78	738	2.33	18934	3 1 5				
	4.1	340.69	826	2.03	19501	3 5 5				
	2.1	643.35	1546	1.11	18581	F 0 7 4 0 6 3 0 _ M _ - 3 7 4 A _	107.0	71b	X 6 1 1 0 6 M 0 5 0 - _ _ _	80
	2.0	699.44	1679	1.02	18581	7 1 0				
	1.7	820.10	1964	0.88	18581	8 0 0				
	1.5	891.60	2134	0.81	18581	9 0 0				
	4.0	344.74	831	2.83	20998	F 0 8 4 0 3 6 0 _ M _ - 3 7 4 A _	150.0	71b	X 6 1 1 0 6 M 0 6 0 - _ _ _	80
	3.4	400.96	966	2.43	20998	4 0 0				
	3.1	439.55	1057	2.22	20998	4 5 0				
	2.7	511.23	1228	1.91	20998	5 0 0				
	2.4	566.66	1363	1.72	20998	5 6 0				
	2.3	605.02	1455	1.61	20998	6 3 0				
	1.9	722.49	1733	1.36	20998	7 1 0				
	1.8	771.40	1849	1.27	20998	8 0 0				
	1.7	808.68	1934	1.44	19052	9 0 0			X 6 1 1 0 7 M 0 6 0 - _ _ _	90
	1.5	940.55	2249	1.24	19052	1 0 C				
	1.3	1031.06	2456	1.13	19052	1 1 C				
	1.2	1199.20	2856	0.98	19052	1 2 C				
	1.0	1329.24	3175	0.88	19052	1 4 C				
	.97	1419.22	3389	0.82	19052	1 6 C			X 6 1 1 0 8 M 0 6 0 - _ _ _	100

NOTE
Other output speeds are available using 2 and 8 pole motors - Consult Textron Power Transmission

SERIES F

SELECTION TABLES

GEARED MOTORS

9608

0.37 kW

6 POLE

Output Speed	N2 R/MIN	i	M2 Nm	Fm	N	UNIT DESIGNATION	Kg	SERIES X	MM	
	Ratio	Output Torque	Service Factor	Overhung Load	Column Entry 1 Through 20 Spaces to be filled when entering order	Weight of Base Mount Unit	Motor Frame Size	Cone Ring Output Coupling Spaces to be filled when entering order	Max Bore Coupling Driven Half	
181	5.11	18	10.83	4870	F 0 4 2 0 5 . 0	M _ - 3 7 6 A _	31.8	80a	X 6 1 1 0 2 M 0 3 0 - _ _ _	42
146	6.32	23	9.92	5210	6 . 3					
129	7.17	26	9.35	5410	7 . 1					
117	7.90	29	8.93	5570	8 . 0					
103	8.97	33	8.36	5790	9 . 0					
95	9.77	36	8.10	5950	10 .			X 6 1 1 0 3 M 0 3 0 - _ _ _	48	
81	11.40	42	7.37	6220	11 .					
71	12.95	47	6.90	6460	12 .					
66	14.09	52	6.64	6630	14 .					
58	16.01	59	6.17	6880	16 .					
52	17.63	65	5.78	7060	18 .					
46	20.03	74	5.08	7320	20 .					
42	21.79	80	4.69	7510	22 .					
37	24.75	91	4.19	7670	25 .					
32	28.82	106	2.66	7335	28 .					
30	31.33	115	2.63	7340	32 .					
26	35.62	131	2.66	7368	36 .					
24	38.72	142	2.63	7317	40 .					
20	45.14	166	1.94	7372	45 .					
18	50.86	187	1.60	7233	50 .					
17	55.79	205	1.88	7150	56 .					
15	62.86	231	1.60	6987	63 .					
14	67.10	246	1.11	7094	71 .			X 6 1 1 0 2 M 0 3 0 - _ _ _	42	
12	76.29	280	0.90	6856	80 .			X 6 1 1 0 3 M 0 3 0 - _ _ _	48	
11	82.94	305	1.11	6739	90 .					
10	94.29	346	0.90	6920	10 0					
14	63.92	233	1.62	6927	F 0 4 3 0 6 3 . _	M _ - 3 7 6 A _	34.8	80a	X 6 1 1 0 3 M 0 3 0 - _ _ _	48
13	73.05	266	1.42	6949	71 .					
12	79.00	288	1.34	6856	80 .					
10	90.28	329	1.17	6571	90 .					
9.4	98.59	359	1.05	6740	10 0					
8.0	115.51	420	0.90	6240	11 2					
7.6	121.85	443	0.87	6150	12 5					
16	56.34	208	3.75	14881	F 0 6 2 0 5 6 . _	M _ - 3 7 6 A _	55.8	80a	X 6 1 1 0 5 M 0 4 5 - _ _ _	70
15	61.69	228	3.46	14845	63 .					
14	67.58	249	2.14	14900	71 .			X 6 1 1 0 4 M 0 4 5 - _ _ _	60	
12	75.79	279	1.36	14900	80 .			X 6 1 1 0 3 M 0 4 5 - _ _ _	48	
11	84.26	310	2.14	14860	90 .			X 6 1 1 0 4 M 0 4 5 - _ _ _	60	
10	94.50	347	1.36	14900	10 0					
15	63.48	234	3.46	14900	F 0 6 3 0 6 3 . _	M _ - 3 7 6 A _	60.8	80a	X 6 1 1 0 5 M 0 4 5 - _ _ _	70
13	72.12	266	3.05	14900	71 .					
12	79.15	289	2.79	14900	80 .					
10	89.92	329	2.45	14900	90 .					
8.9	103.79	380	2.13	14389	10 0					
8.2	112.84	413	1.96	14860	11 2					
7.1	129.41	473	1.70	14701	12 5					
6.6	140.70	514	1.57	14503	14 0					
5.7	162.55	594	1.39	14667	16 0					
5.1	183.16	669	1.25	14260	18 0					
4.6	202.68	738	1.09	14086	20 0					
4.1	228.38	831	0.97	14800	22 5					
3.8	241.67	882	0.98	14500	25 0					
3.4	274.74	1002	0.87	13700	28 0					
14	68.02	250	3.72	19700	F 0 7 2 0 7 1 . _	M _ - 3 7 6 A _	84.8	80a	X 6 1 1 0 5 M 0 5 0 - _ _ _	70
12	75.58	276	2.76	19700	80 .					
11	84.78	310	3.26	19700	90 .					
10	94.20	344	2.76	19700	10 0					
7.1	130.00	474	3.54	19373	F 0 7 3 0 1 2 5 _	M _ - 3 7 6 A _	93.8	80a	X 6 1 1 0 6 M 0 5 0 - _ _ _	80
6.7	138.80	507	3.31	19265	14 0					
5.7	162.96	594	2.66	19317	16 0					
5.2	178.44	651	2.46	19113	18 0					
4.6	203.11	738	2.27	18909	20 0					
4.2	222.40	808	2.08	18628	22 5					
3.8	243.74	886	1.83	19065	25 0					
3.4	273.36	991	1.36	19600	28 0					
3.0	303.78	1102	1.56	19600	31 5					
2.5	368.51	1319	1.30	18581	F 0 7 4 0 3 6 0 _	M _ - 3 7 6 A _	110.8	80a	X 6 1 1 0 6 M 0 5 0 - _ _ _	80
2.4	393.50	1412	1.22	18581	40 0					
2.1	447.04	1603	1.07	18581	45 0					
1.8	501.60	1794	0.96	18581	50 0					
1.6	569.85	2037	0.85	18581	56 0					
4.6	202.29	738	3.78	24700	F 0 8 3 0 2 0 0 _	M _ - 3 7 6 A _	135.8	80a	X 6 1 1 0 7 M 0 6 0 - _ _ _	90
4.2	222.21	811	3.44	24700	22 5					
3.8	242.37	882	3.15	24700	25 0					
3.3	279.09	1016	2.73	24700	28 0					
3.1	297.37	1082	2.58	24700	31 5					
2.7	342.42	1241	2.25	24700	35 5					
2.7	344.74	1237	1.90	20998	F 0 8 4 0 3 6 0 _	M _ - 3 7 6 A _	153.8	80a	X 6 1 1 0 6 M 0 6 0 - _ _ _	80
2.3	400.96	1438	1.63	20998	40 0					
2.1	439.55	1572	1.49	20998	45 0					
1.8	511.23	1827	1.29	20998	50 0					
1.6	566.66	2029	1.16	20998	56 0					
1.5	605.02	2165	1.08	20998	63 0					
1.3	722.49	2577	0.91	20998	71 0					
1.2	771.40	2750	0.85	20998	80 0			X 6 1 1 0 7 M 0 6 0 - _ _ _	90	
1.1	808.68	2873	0.97	19052	90 0					
.98	940.55	3341	0.83	19052	10 C					
2.9	315.41	1152	3.67	33100	F 0 9 3 0 3 1 5 _	M _ - 3 7 6 A _	195.8	80a	X 6 1 1 0 8 M 0 7 0 - _ _ _	100
2.6	354.67	1289	3.28	33100	35 5					
2.6	358.73	1290	3.27	32924	F 0 9 4 0 3 6 0 _	M _ - 3 7 6 A _	226.8	80a	X 6 1 1 0 8 M 0 7 0 - _ _ _	100
2.2	412.21	1482	2.85	32924	40 0					
2.0	457.90	1638	2.58	32924	45 0					
1.8	526.17	1881	2.25	32924	50 0					
1.6	590.45	2119	1.99	32924	56 0					
1.4	667.58	2394	1.76	32924	63 0					
1.2	753.67	2690	1.57	32924	71 0					
1.1	852.13	3038	1.39	32924	80 0					
1.1	854.97	3034	1.39	32924	90 0					
.94	982.44	3486	1.21	32924	10 C					
.85	1091.32	3845	1.10	32924	11 C					
.74	1254.03	4418	0.96	32924	12 C					
.66	1407.23	4993	0.85	32924	14 C					

NOTE
Other output speeds are available using 2 and 8 pole motors - Consult Textron Power Transmission

SERIES F

SELECTION TABLES

GEARED MOTORS

9608

0.55 kW

4 POLE

N2 R/MIN	i	M2 Nm	Fm	N	UNIT DESIGNATION	Kg	SERIES X	MM
Output Speed	Ratio	Output Torque	Service Factor	Overhung Load	Column Entry <input type="text" value="1"/> Through <input type="text" value="20"/> Spaces to be filled when entering order	Weight of Base Mount Unit	Cone Ring Output Coupling Spaces to be filled when entering order	Max Bore Coupling Driven Half
268	5.11	18	9.53	4370	F 0 4 2 0 5 . 0 _ M _ - 5 5 4 A _	31.4		
217	6.32	23	8.74	4550	6 . 3			
191	7.17	26	8.25	4690	7 . 1			
173	7.90	29	7.87	4830	8 . 0			
153	8.97	33	7.37	5020	9 . 0			
140	9.77	36	7.15	5160	10 .			
120	11.40	42	6.49	5390	11 .			
106	12.95	48	6.08	5590	12 .		X 6 1 1 0 2 M 0 3 0 - _ _ _	48
97	14.09	52	5.86	5740	14 .			
86	16.01	59	5.46	5950	16 .			
78	17.63	65	5.10	6090	18 .			
68	20.03	74	4.74	6310	20 .			
63	21.79	80	4.48	6470	22 .			
55	24.75	91	4.00	6700	25 .			
48	28.82	107	2.61	6940	28 .			
44	31.33	116	2.46	6987	32 .			
38	35.62	132	2.61	7012	36 .			
35	38.72	143	2.46	7009	40 .			
30	45.14	167	1.75	7103	45 .			
27	50.86	187	1.59	7117	50 .			
25	55.79	207	1.75	7139	56 .			
22	62.86	232	1.59	6963	63 .			
20	67.10	247	1.07	7192	71 .		X 6 1 1 0 2 M 0 3 0 - _ _ _	42
18	76.29	281	0.89	6939	80 .		X 6 1 1 0 3 M 0 3 0 - _ _ _	48
17	82.94	305	1.07	6816	90 .			
15	94.29	347	0.89	6970	100			
21	63.92	234	1.61	6902	F 0 4 3 0 6 3 . _ M _ - 5 5 4 A _	34.4	X 6 1 1 0 3 M 0 3 0 - _ _ _	48
19	73.05	267	1.41	7042	71 .			
17	79.00	289	1.33	6939	80 .			
15	90.28	330	1.17	6639	90 .			
14	98.59	360	1.05	6790	100			
12	115.51	422	0.90	6290	112			
11	121.85	445	0.87	6200	125			
24	56.34	209	3.42	14481	F 0 6 2 0 5 6 . _ M _ - 5 5 4 A _	55.4	X 6 1 1 0 4 M 0 4 5 - _ _ _	60
22	61.69	229	3.16	14713	63 .		X 6 1 1 0 5 M 0 4 5 - _ _ _	70
20	67.58	251	2.13	14868	71 .		X 6 1 1 0 4 M 0 4 5 - _ _ _	60
18	75.79	280	1.36	14868	80 .		X 6 1 1 0 3 M 0 4 5 - _ _ _	48
16	84.26	312	2.13	14868	90 .		X 6 1 1 0 4 M 0 4 5 - _ _ _	60
14	94.50	348	1.36	14900	100			
22	63.48	233	3.47	14900	F 0 6 3 0 6 3 . _ M _ - 5 5 4 A _	60.4	X 6 1 1 0 5 M 0 4 5 - _ _ _	70
19	72.12	266	3.04	14900	71 .			
17	79.15	291	2.77	14900	80 .			
15	89.92	330	2.44	14900	90 .			
13	103.79	380	2.13	14494	100			
12	112.84	414	1.96	14856	112			
11	129.41	474	1.70	14724	125			
10	140.70	516	1.56	14505	140			
8.4	162.55	596	1.36	13934	160			
7.5	183.16	671	1.21	14558	180			
6.8	202.68	741	1.09	14422	200			
6.0	228.38	833	0.97	13876	225			
5.7	241.67	886	0.93	14600	250			
5.0	274.74	1005	0.83	13800	280			
20	68.02	250	3.71	19700	F 0 7 2 0 7 1 . _ M _ - 5 5 4 A _	84.4	X 6 1 1 0 5 M 0 5 0 - _ _ _	70
18	75.58	279	2.73	19700	80 .			
16	84.78	313	2.95	19700	90 .			
15	94.20	347	2.66	19700	100			
11	130.00	474	3.54	19389	F 0 7 3 0 1 2 5 _ M _ - 5 5 4 A _	93.4	X 6 1 1 0 6 M 0 5 0 - _ _ _	80
10	138.80	506	3.32	19265	140			
8.4	162.96	598	2.42	19513	160			
7.7	178.44	653	2.23	19294	180			
6.7	203.11	740	2.27	19045	200			
6.2	222.40	808	2.08	18765	225			
5.6	243.74	888	1.67	19129	250			
5.0	273.36	994	1.36	18646	280			
4.5	303.78	1106	1.55	18383	315			
3.7	368.51	1326	1.30	18581	F 0 7 4 0 3 6 0 _ M _ - 5 5 4 A _	110.4	X 6 1 1 0 6 M 0 5 0 - _ _ _	80
3.5	393.50	1419	1.21	18581	400			
3.1	447.04	1612	1.07	18581	450			
2.7	501.60	1804	0.95	18581	500			
2.4	569.85	2048	0.84	18581	560			
6.8	202.29	738	3.78	24700	F 0 8 3 0 2 0 0 _ M _ - 5 5 4 A _	135.4	X 6 1 1 0 7 M 0 6 0 - _ _ _	90
6.2	222.21	812	3.44	24700	225			
5.7	242.37	884	3.14	24700	250			
4.9	279.09	1017	2.73	24700	280			
4.6	297.37	1082	2.58	24700	315			
4.0	342.42	1249	2.23	24700	355			

NOTE
Other output speeds are available using 2 and 8 pole motors - Consult Textron Power Transmission

SERIES F

SELECTION TABLES

GEARED MOTORS

9608

0.55 kW	N2 R/MIN	i	M2 Nm	Fm	N	UNIT DESIGNATION	Kg	SERIES X	MM	
4 POLE	Output Speed	Ratio	Output Torque	Service Factor	Overhung Load	Column Entry 1 Through 20 Spaces to be filled when entering order	Weight of Base Mount Unit	Motor Frame Size	Cone Ring Output Coupling Spaces to be filled when entering order	Max Bore Coupling Driven Half
	4.0	344.74	1245	1.89	20998	F 0 8 4 0 3 6 0 _ M _ - _ - . 5 5 4 A _	153.4	80a	X 6 1 1 0 6 M 0 6 0 - _ - -	80
	3.4	400.96	1447	1.62	20998	4 0 0				
	3.1	439.55	1582	1.48	20998	4 5 0				
	2.7	511.23	1839	1.28	20998	5 0 0				
	2.4	566.66	2042	1.15	20998	5 6 0				
	2.3	605.02	2179	1.08	20998	6 3 0				
	1.9	722.49	2595	0.91	20998	7 1 0			X 6 1 1 0 7 M 0 6 0 - _ - -	90
	1.8	771.40	2769	0.85	20998	8 0 0				
	1.7	808.68	2896	0.96	19052	9 0 0				
	1.5	940.55	3367	0.83	19052	1 0 C			X 6 1 1 0 8 M 0 6 0 - _ - -	100
	4.3	315.41	1150	3.68	33100	F 0 9 3 0 3 1 5 _ M _ - _ - . 5 5 4 A _	195.4	80a	X 6 1 1 0 8 M 0 7 0 - _ - -	100
	3.9	354.67	1295	3.26	33100	3 5 5				
	3.8	358.73	1299	3.25	32924	F 0 9 4 0 3 6 0 _ M _ - _ - . 5 5 4 A _	226.4	80a	X 6 1 1 0 8 M 0 7 0 - _ - -	100
	3.3	412.21	1492	2.83	32924	4 0 0				
	3.0	457.90	1650	2.56	32924	4 5 0				
	2.6	526.17	1894	2.23	32924	5 0 0				
	2.3	590.45	2133	1.98	32924	5 6 0				
	2.1	667.58	2409	1.75	32924	6 3 0				
	1.8	753.67	2709	1.56	32924	7 1 0				
	1.6	852.13	3060	1.38	32924	8 0 0				
	1.6	854.97	3062	1.38	32924	9 0 0				
	1.4	982.44	3517	1.20	32924	1 0 C				
	1.3	1091.32	3884	1.09	32924	1 1 C				
	1.1	1254.03	4463	0.95	32924	1 2 C				
	.97	1407.23	5035	0.84	32924	1 4 C				
	2.4	577.03	2088	3.47	43248	F 1 0 4 0 5 6 0 _ M _ - _ - . 5 5 4 A _	349.4	80a	X 6 1 1 0 9 M 0 9 0 - _ - -	120
	2.1	651.34	2355	3.08	43248	6 3 0				
	1.9	716.06	2584	2.81	43248	7 1 0				
	1.7	808.27	2915	2.49	43248	8 0 0				
	.96	1424.92	5098	1.42	43248	1 4 C				
	.85	1608.41	5753	1.26	43248	1 6 C				
	.77	1768.23	6303	1.15	43248	1 8 C				
	.69	1995.94	7113	1.02	43248	2 0 C				
	.60	2273.80	8120	0.89	43248	2 2 C				
	.55	2497.68	8915	0.81	43248	2 5 C			X 6 1 1 1 0 M 0 9 0 - _ - -	140
	181	5.11	28	7.29	4795	F 0 4 2 0 5 . 0 _ M _ - _ - . 5 5 6 A _	33.3	80b	X 6 1 1 0 2 M 0 3 0 - _ - -	42
	146	6.32	34	6.67	5119	6 . 3				
	129	7.17	39	6.29	5303	7 . 1				
	117	7.90	43	6.01	5453	8 . 0				
	103	8.97	49	5.62	5657	9 . 0			X 6 1 1 0 3 M 0 3 0 - _ - -	48
	95	9.77	53	5.45	5809	1 0 .				
	81	11.40	62	4.96	6051	1 1 .				
	71	12.95	71	4.64	6269	1 2 .				
	66	14.09	77	4.47	6428	1 4 .				
	58	16.01	88	4.15	6650	1 6 .				
	52	17.63	97	3.89	6800	1 8 .				
	46	20.03	110	3.42	7024	2 0 .				
	42	21.79	120	3.15	7197	2 2 .				
	37	24.75	136	2.82	7332	2 5 .				
	32	28.82	157	1.79	7095	2 8 .				
	30	31.33	171	1.77	7103	3 2 .				
	26	35.62	194	1.79	7152	3 6 .				
	24	38.72	211	1.77	7064	4 0 .				
	20	45.14	247	1.31	7158	4 5 .				
	18	50.86	278	1.07	6919	5 0 .				
	17	55.79	305	1.26	6775	5 6 .				
	15	62.86	343	1.07	6496	6 3 .				
	14	63.92	347	1.09	6393	F 0 4 3 0 6 3 . _ M _ - _ - . 5 5 6 A _	36.3	80b	X 6 1 1 0 3 M 0 3 0 - _ - -	48
	13	73.05	396	0.95	6430	7 1 .				
	12	79.00	428	0.90	6270	8 0 .				
	24	38.50	212	3.78	14693	F 0 6 2 0 4 0 . _ M _ - _ - . 5 5 6 A _	57.3	80b	X 6 1 1 0 5 M 0 4 5 - _ - -	70
	20	45.18	248	3.26	14651	4 5 .				
	19	49.47	272	2.98	14868	5 0 .				
	16	56.34	310	2.52	14868	5 6 .				
	15	61.69	339	2.33	14806	6 3 .				
	14	67.58	371	1.44	14900	7 1 .			X 6 1 1 0 4 M 0 4 5 - _ - -	60
	12	75.79	415	0.92	14900	8 0 .			X 6 1 1 0 3 M 0 4 5 - _ - -	48
	11	84.26	461	1.44	14831	9 0 .			X 6 1 1 0 4 M 0 4 5 - _ - -	60
	15	63.48	348	2.33	14772	F 0 6 3 0 6 3 . _ M _ - _ - . 5 5 6 A _	62.3	80b	X 6 1 1 0 5 M 0 4 5 - _ - -	70
	13	72.12	395	2.05	14875	7 1 .				
	12	79.15	429	1.87	14875	8 0 .				
	10	89.92	489	1.65	14727	9 0 .				
	8.9	103.79	565	1.43	14022	1 0 0				
	8.2	112.84	614	1.32	14831	1 1 2				
	7.1	129.41	703	1.15	14558	1 2 5				
	6.6	140.70	765	1.05	14217	1 4 0				
	5.7	162.55	883	0.93	14500	1 6 0				
	5.1	183.16	995	0.84	13800	1 8 0				
	14	68.02	371	2.51	19684	F 0 7 2 0 7 1 . _ M _ - _ - . 5 5 6 A _	86.3	80b	X 6 1 1 0 5 M 0 5 0 - _ - -	70
	12	75.58	411	1.86	19684	8 0 .				
	11	84.78	461	2.19	19684	9 0 .				
	10	94.20	511	1.86	19684	1 0 0				

NOTE
Other output speeds are available using 2 and 8 pole motors - Consult Textron Power Transmission

SERIES F

SELECTION TABLES

GEARED MOTORS

9608

0.55 kW

6 POLE

N2 R/MIN	i	M2 Nm	Fm	N	UNIT DESIGNATION	Kg	SERIES X	MM	
Output Speed	Ratio	Output Torque	Service Factor	Overhung Load	Column Entry 1 Through 20 Spaces to be filled when entering order	Weight of Base Mount Unit	Cone Ring Output Coupling Spaces to be filled when entering order	Max Bore Coupling Driven Half	
						Motor Frame Size			
12	79.09	430	3.91	19117	F 0 7 3 0 8 0 . . M _ - 5 5 6 A _	95.3	80b	X 6 1 1 0 6 M 0 5 0 - _ _ _	80
10	91.99	499	3.36	19245	9 0 .				
8.9	104.31	567	2.93	18873	1 0 0				
8.3	111.37	607	2.73	19419	1 1 2				
7.1	130.00	705	2.38	19139	1 2 5				
6.7	138.80	755	2.22	18952	1 4 0				
5.7	162.96	884	1.79	19041	1 6 0				
5.2	178.44	968	1.65	18690	1 8 0				
4.6	203.11	1098	1.53	18339	2 0 0				
2.5	368.51	1960	0.88	18581	F 0 7 4 0 3 6 0 _ M _ - 5 5 6 A _	112.3	80b	X 6 1 1 0 6 M 0 5 0 - _ _ _	80
2.4	393.50	2099	0.82	18581	4 0 0				
6.5	143.09	776	3.59	24060	F 0 8 3 0 1 4 0 _ M _ - 5 5 6 A _	137.3	80b	X 6 1 1 0 7 M 0 6 0 - _ _ _	90
5.6	164.88	896	3.10	23785	1 6 0				
5.1	181.11	985	2.82	23871	1 8 0				
4.6	202.29	1098	2.54	23744	2 0 0				
4.2	222.21	1206	2.31	23537	2 2 5				
3.8	242.37	1311	2.12	23218	2 5 0				
3.3	279.09	1511	1.84	23047	2 8 0				
3.1	297.37	1608	1.73	22973	3 1 5				
2.7	342.42	1845	1.51	22456	3 5 5				
2.7	344.74	1839	1.28	20998	F 0 8 4 0 3 6 0 _ M _ - 5 5 6 A _	155.3	80b	X 6 1 1 0 6 M 0 6 0 - _ _ _	80
2.3	400.96	2138	1.10	20998	4 0 0				
2.1	439.55	2336	1.01	20998	4 5 0				
1.8	511.23	2716	0.87	20998	5 0 0			X 6 1 1 0 7 M 0 6 0 - _ _ _	90
4.5	207.69	1128	3.75	33080	F 0 9 3 0 2 0 0 _ M _ - 5 5 6 A _	197.3	80b	X 6 1 1 0 8 M 0 7 0 - _ _ _	100
4.0	229.28	1244	3.40	33080	2 2 5				
3.8	244.23	1322	3.26	33070	2 5 0				
3.4	274.63	1491	2.89	33084	2 8 0				
2.9	315.41	1712	2.47	33068	3 1 5				
2.6	354.67	1916	2.21	33052	3 5 5				
2.6	358.73	1918	2.20	32924	F 0 9 4 0 3 6 0 _ M _ - 5 5 6 A _	228.3	80b	X 6 1 1 0 8 M 0 7 0 - _ _ _	100
2.2	412.21	2203	1.92	32924	4 0 0				
2.0	457.90	2435	1.73	32924	4 5 0				
1.8	526.17	2797	1.51	32924	5 0 0				
1.6	590.45	3151	1.34	32924	5 6 0				
1.4	667.58	3559	1.19	32924	6 3 0				
1.2	753.67	3999	1.06	32924	7 1 0				
1.1	852.13	4517	0.94	32924	8 0 0				
1.1	854.97	4510	0.94	32924	9 0 0				
.94	982.44	5183	0.82	32924	1 0 C			X 6 1 1 0 9 M 0 7 0 - _ _ _	120
2.7	343.57	1855	3.91	43470	F 1 0 3 0 3 5 5 _ M _ - 5 5 6 A _	291.3	80b	X 6 1 1 0 9 M 0 9 0 - _ _ _	120
1.6	577.03	3084	2.35	43248	F 1 0 4 0 5 6 0 _ M _ - 5 5 6 A _	351.3	80b	X 6 1 1 0 9 M 0 9 0 - _ _ _	120
1.4	651.34	3478	2.08	43248	6 3 0				
1.3	716.06	3814	1.90	43248	7 1 0				
1.1	808.27	4302	1.69	43248	8 0 0				
.65	1424.92	7509	0.97	43248	1 4 C				
.58	1608.41	8476	0.86	43248	1 6 C			X 6 1 1 1 0 M 0 9 0 - _ _ _	140

NOTE
Other output speeds are available using 2 and 8 pole motors - Consult Textron Power Transmission

SERIES F

SELECTION TABLES

GEARED MOTORS

9608

	N2 R/MIN	i	M2 Nm	Fm	N	UNIT DESIGNATION	Kg	SERIES X	MM	
	Output Speed	Ratio	Output Torque	Service Factor	Overhung Load	Column Entry 1 Through 20 Spaces to be filled when entering order	Weight of Base Mount Unit	Cone Ring Output Coupling Spaces to be filled when entering order	Max Bore Coupling Driven Half	
0.75 kW	4 POLE									
	271	5.11	25	7.07	4314	F 0 4 2 0 5 . 0 _ M _ - 7 5 4 A _	32.5	80b	X 6 1 1 0 2 M 0 3 0 - _ _ _	42
	219	6.32	31	6.48	4483	6 . 3				
	193	7.17	35	6.11	4612	7 . 1				
	175	7.90	39	5.83	4744	8 . 0				
	154	8.97	45	5.46	4922	9 . 0				
	142	9.77	49	5.30	5056	1 0 .				
	122	11.40	57	4.81	5265	1 1 .				
	107	12.95	64	4.51	5449	1 2 .			X 6 1 1 0 3 M 0 3 0 - _ _ _	48
	98	14.09	70	4.34	5591	1 4 .				
	87	16.01	80	4.05	5780	1 6 .				
	79	17.63	88	3.78	5899	1 8 .				
	69	20.03	100	3.52	6092	2 0 .				
	64	21.79	109	3.32	6240	2 2 .				
	56	24.75	124	2.97	6438	2 5 .				
	48	28.82	144	1.94	6628	2 8 .				
	44	31.33	156	1.82	6670	3 2 .				
	39	35.62	178	1.94	6706	3 6 .				
	36	38.72	193	1.82	6702	4 0 .				
	31	45.14	226	1.30	6840	4 5 .				
	27	50.86	253	1.18	6860	5 0 .				
	25	55.79	279	1.30	6892	5 6 .				
22	62.86	313	1.18	6635	6 3 .					
22	63.92	316	1.20	6545	F 0 4 3 0 6 3 . _ M _ - 7 5 4 A _	35.5	80b	X 6 1 1 0 3 M 0 3 0 - _ _ _	48	
19	73.05	361	1.05	6750	7 1 .					
18	79.00	390	0.99	6600	8 0 .					
15	90.28	445	0.87	6160	9 0 .					
31	45.18	227	3.57	14221	F 0 6 2 0 4 5 . _ M _ - 7 5 4 A _	56.5	80b	X 6 1 1 0 5 M 0 4 5 - _ _ _	70	
28	49.47	248	3.26	14221	5 0 .			X 6 1 1 0 4 M 0 4 5 - _ _ _	60	
25	56.34	282	2.53	14287	5 6 .			X 6 1 1 0 5 M 0 4 5 - _ _ _	70	
22	61.69	308	2.34	14627	6 3 .			X 6 1 1 0 4 M 0 4 5 - _ _ _	60	
20	67.58	338	1.58	14854	7 1 .			X 6 1 1 0 3 M 0 4 5 - _ _ _	48	
18	75.79	377	1.01	14854	8 0 .			X 6 1 1 0 4 M 0 4 5 - _ _ _	60	
16	84.26	421	1.58	14854	9 0 .					
15	94.50	470	1.01	14900	1 0 0					
22	63.48	315	2.57	14754	F 0 6 3 0 6 3 . _ M _ - 7 5 4 A _	61.5	80b	X 6 1 1 0 5 M 0 4 5 - _ _ _	70	
19	72.12	359	2.25	14730	7 1 .					
17	79.15	393	2.05	14878	8 0 .					
15	89.92	445	1.81	14878	9 0 .					
13	103.79	513	1.58	14306	1 0 0					
12	112.84	558	1.45	14835	1 1 2					
11	129.41	640	1.26	14642	1 2 5					
10	140.70	696	1.16	14321	1 4 0					
8.5	162.55	804	1.01	13485	1 6 0					
7.6	183.16	905	0.90	14400	1 8 0					
6.8	202.68	999	0.81	14200	2 0 0					
20	68.02	338	2.75	19687	F 0 7 2 0 7 1 . _ M _ - 7 5 4 A _	85.5	80b	X 6 1 1 0 5 M 0 5 0 - _ _ _	70	
18	75.58	376	2.02	19687	8 0 .					
16	84.78	422	2.19	19687	9 0 .					
15	94.20	468	1.97	19687	1 0 0					
19	73.81	367	3.95	19147	F 0 7 3 0 7 1 . _ M _ - 7 5 4 A _	94.5	80b	X 6 1 1 0 6 M 0 5 0 - _ _ _	80	
15	91.99	454	3.69	19018	9 0 .					
13	104.31	516	3.16	19065	1 0 0					
12	111.37	552	3.01	19518	1 1 2					
11	130.00	640	2.62	19245	1 2 5					
10	138.80	683	2.46	19063	1 4 0					
8.5	162.96	807	1.80	19426	1 6 0					
7.8	178.44	881	1.66	19106	1 8 0					
6.8	203.11	999	1.68	18741	2 0 0					
6.2	222.40	1090	1.54	18330	2 2 5					
5.7	243.74	1198	1.24	18864	2 5 0					
5.1	273.36	1341	1.01	18157	2 8 0					
4.6	303.78	1492	1.15	17771	3 1 5					
4.1	340.69	1669	1.01	19200	3 5 5					
3.8	368.51	1789	0.96	18581	F 0 7 4 0 3 6 0 _ M _ - 7 5 4 A _	111.5	80b	X 6 1 1 0 6 M 0 5 0 - _ _ _	80	
3.5	393.50	1915	0.90	18581	4 0 0					
10	143.09	704	3.96	24166	F 0 8 3 0 1 4 0 _ M _ - 7 5 4 A _	136.5	80b	X 6 1 1 0 7 M 0 6 0 - _ _ _	90	
8.4	164.88	814	3.41	24071	1 6 0					
7.6	181.11	894	3.11	23957	1 8 0					
6.8	202.29	995	2.80	24021	2 0 0					
6.2	222.21	1095	2.55	23863	2 2 5					
5.7	242.37	1192	2.33	23633	2 5 0					
5.0	279.09	1372	2.02	23563	2 8 0					
4.7	297.37	1460	1.91	23500	3 1 5					
4.0	342.42	1685	1.66	23121	3 5 5					
4.0	344.74	1679	1.40	20998	F 0 8 4 0 3 6 0 _ M _ - 7 5 4 A _	154.5	80b	X 6 1 1 0 6 M 0 6 0 - _ _ _	80	
3.5	400.96	1952	1.20	20998	4 0 0					
3.2	439.55	2135	1.10	20998	4 5 0					
2.7	511.23	2481	0.95	20998	5 0 0			X 6 1 1 0 7 M 0 6 0 - _ _ _	90	
2.4	566.66	2754	0.85	20998	5 6 0					
6.0	229.28	1133	3.73	33083	F 0 9 3 0 2 2 5 _ M _ - 7 5 4 A _	196.5	80b	X 6 1 1 0 8 M 0 7 0 - _ _ _	100	
5.7	244.23	1204	3.58	33083	2 5 0					
5.0	274.63	1353	3.18	33075	2 8 0					
4.4	315.41	1552	2.73	33075	3 1 5					
3.9	354.67	1748	2.42	33075	3 5 5					

NOTE
Other output speeds are available using 2 and 8 pole motors - Consult Textron Power Transmission

SERIES F

SELECTION TABLES

GEARED MOTORS

9608

0.75 kW	N2 R/MIN	i	M2 Nm	Fm	N	UNIT DESIGNATION	Kg		SERIES X	MM								
	Output Speed	Ratio	Output Torque	Service Factor	Overhung Load	Column Entry 1 Through 20 Spaces to be filled when entering order	Weight of Base Mount Unit	Motor Frame Size	Cone Ring Output Coupling Spaces to be filled when entering order	Max Bore Coupling Driven Half								
4 POLE	3.9	358.73	1752	2.41	32924	F 0 9 4 0 3 6 0 _ M _ - 7 5 4 A _	227.5	80b	X 6 1 1 0 8 M 0 7 0 - _ _ _	100								
	3.4	412.21	2012	2.10	32924	4 0 0												
	3.0	457.90	2225	1.90	32924	4 5 0												
	2.6	526.17	2555	1.65	32924	5 0 0												
	2.3	590.45	2877	1.47	32924	5 6 0												
	2.1	667.58	3250	1.30	32924	6 3 0												
	1.8	753.67	3654	1.16	32924	7 1 0												
	1.6	852.13	4128	1.02	32924	8 0 0												
	1.6	854.97	4130	1.02	32924	9 0 0												
	1.4	982.44	4745	0.89	32924	1 0 C												
	1.3	1091.32	5240	0.81	32924	1 1 C												
	2.4	577.03	2816	2.58	43248	F 1 0 4 0 5 6 0 _ M _ - 7 5 4 A _					350.5	80b	X 6 1 1 0 9 M 0 9 0 - _ _ _	120				
	2.1	651.34	3177	2.28	43248	6 3 0												
	1.9	716.06	3486	2.08	43248	7 1 0												
	1.7	808.27	3932	1.84	43248	8 0 0												
	.97	1424.92	6876	1.05	43248	1 4 C												
	.86	1608.41	7760	0.93	43248	1 6 C												
	.78	1768.23	8502	0.85	43248	1 8 C												
	178	5.11	38	5.26	4712	F 0 4 2 0 5 . 0 _ M _ - 7 5 6 A _									36.4	90S	X 6 1 1 0 2 M 0 3 0 - _ _ _	42
	144	6.32	48	4.82	5018	6 . 3												
127	7.17	54	4.54	5185	7 . 1													
115	7.90	60	4.34	5324	8 . 0													
101	8.97	68	4.06	5509	9 . 0													
93	9.77	74	3.93	5653	1 0 .													
80	11.40	87	3.58	5864	1 1 .													
70	12.95	98	3.35	6057	1 2 .													
65	14.09	107	3.22	6204	1 4 .													
57	16.01	122	3.00	6396	1 6 .													
52	17.63	134	2.81	6511	1 8 .													
45	20.03	153	2.46	6697	2 0 .													
42	21.79	166	2.27	6849	2 2 .													
37	24.75	188	2.03	6957	2 5 .													
32	28.82	218	1.29	6827	2 8 .													
29	31.33	237	1.28	6840	3 2 .													
26	35.62	269	1.29	6911	3 6 .													
23	38.72	293	1.28	6782	4 0 .													
20	45.14	343	0.94	6920	4 5 .													
16	55.79	423	0.91	6360	5 6 .													
31	28.92	221	3.60	14200	F 0 6 2 0 2 8 . _ M _ - 7 5 6 A _	61.4	90S	X 6 1 1 0 5 M 0 4 5 - _ _ _	70									
29	30.88	236	3.43	14200	3 2 .													
25	36.06	275	2.92	14566	3 6 .													
24	38.50	294	2.73	14597	4 0 .													
20	45.18	344	2.35	14536	4 5 .													
18	49.47	377	2.15	14854	5 0 .													
16	56.34	430	1.82	14854	5 6 .													
15	61.69	471	1.68	14763	6 3 .													
13	67.58	514	1.04	14900	7 1 .													
11	84.26	640	1.04	14800	9 0 .													
14	63.48	482	1.68	14630	F 0 6 3 0 6 3 . _ M _ - 7 5 6 A _	66.4	90S	X 6 1 1 0 5 M 0 4 5 - _ _ _	70									
13	72.12	548	1.48	14847	7 1 .													
11	79.15	595	1.35	14847	8 0 .													
10	89.92	679	1.19	14535	9 0 .													
8.8	103.79	784	1.03	13614	1 0 0													
8.1	112.84	852	0.95	14800	1 1 2													
7.0	129.41	975	0.83	14400	1 2 5													
15	61.40	466	3.69	19497	F 0 7 2 0 6 3 . _ M _ - 7 5 6 A _					89.4	90S	X 6 1 1 0 6 M 0 5 0 - _ _ _ X 6 1 1 0 5 M 0 5 0 - _ _ _	80 70					
13	68.02	515	1.81	19666	7 1 .													
12	75.58	570	1.34	19666	8 0 .													
11	84.78	639	1.58	19666	9 0 .													
10	94.20	709	1.34	19666	1 0 0													
14	63.46	479	3.15	19240	F 0 7 3 0 6 3 . _ M _ - 7 5 6 A _	99.4	90S	X 6 1 1 0 6 M 0 5 0 - _ _ _	80									
12	73.81	557	2.91	18912	7 1 .													
12	79.09	596	2.82	18846	8 0 .													
10	91.99	692	2.43	19033	9 0 .													
8.7	104.31	786	2.11	18488	1 0 0													
8.2	111.37	841	1.97	19289	1 1 2													
7.0	130.00	977	1.72	18878	1 2 5													
6.6	138.80	1046	1.61	18604	1 4 0													
5.6	162.96	1225	1.29	18735	1 6 0													
5.1	178.44	1342	1.19	18221	1 8 0													
4.5	203.11	1522	1.10	17707	2 0 0													
4.1	222.40	1665	1.01	17000	2 2 5													
3.7	243.74	1825	0.89	18100	2 5 0													
12	77.20	585	3.26	24179	F 0 8 2 0 8 0 . _ M _ - 7 5 6 A _					135.4	90S	X 6 1 1 0 6 M 0 6 0 - _ _ _	80					
10	94.71	717	3.26	23934	1 0 0													

NOTE
Other output speeds are available using 2 and 8 pole motors - Consult Textron Power Transmission

SERIES F

SELECTION TABLES

GEARED MOTORS

9608

0.75 kW

6 POLE

N2 R/MIN	i	M2 Nm	Fm	N	UNIT DESIGNATION	Kg	SERIES X	MM	
Output Speed	Ratio	Output Torque	Service Factor	Overhung Load	Column Entry 1 Through 20 Spaces to be filled when entering order	Weight of Base Mount Unit	Cone Ring Output Coupling Spaces to be filled when entering order	Max Bore Coupling Driven Half	
						Motor Frame Size			
8.8	103.32	779	3.56	23688	F 0 8 3 0 1 0 0 _ M _ - 7 5 6 A _	140.4	90S	X 6 1 1 0 7 M 0 6 0 -	90
7.8	116.63	879	3.16	23442					
7.2	126.77	951	2.93	23356					
6.4	143.09	1076	2.59	23350					
5.5	164.88	1242	2.24	22768					
5.0	181.11	1366	2.03	22951					
4.5	202.29	1522	1.83	22682					
4.1	222.21	1672	1.67	22245					
3.8	242.37	1817	1.53	21572					
3.3	279.09	2094	1.33	21212					
3.1	297.37	2229	1.25	21056					
2.7	342.42	2557	1.09	19963					
2.6	344.74	2550	0.92	20998	F 0 8 4 0 3 6 0 _ M _ - 7 5 6 A _	158.4	90S	X 6 1 1 0 7 M 0 6 0 -	90
6.2	147.03	1108	3.82	33079	F 0 9 3 0 1 4 0 _ M _ - 7 5 6 A _	200.4	90S	X 6 1 1 0 8 M 0 7 0 -	100
5.7	160.82	1213	3.55	33079					
5.1	177.54	1337	3.22	33079					
4.4	207.69	1563	2.70	33058					
4.0	229.28	1725	2.45	33058					
3.7	244.23	1833	2.35	33037					
3.3	274.63	2066	2.09	33066					
2.9	315.41	2373	1.78	33032					
2.6	354.67	2656	1.59	32999					
2.5	358.73	2659	1.59	32924	F 0 9 4 0 3 6 0 _ M _ - 7 5 6 A _	231.4	90S	X 6 1 1 0 8 M 0 7 0 -	100
2.2	412.21	3054	1.38	32924					
2.0	457.90	3376	1.25	32924					
1.7	526.17	3877	1.09	32924					
1.5	590.45	4367	0.97	32924					
1.4	667.58	4933	0.86	32924					
3.6	253.86	1910	3.35	43456	F 1 0 3 0 2 5 0 _ M _ - 7 5 6 A _	294.4	90S	X 6 1 1 0 9 M 0 9 0 -	120
3.3	272.75	2050	3.12	43456					
2.8	319.79	2400	3.02	43442					
2.6	343.57	2572	2.82	43437					
1.6	577.03	4275	1.70	43248	F 1 0 4 0 5 6 0 _ M _ - 7 5 6 A _	354.4	90S	X 6 1 1 0 9 M 0 9 0 -	120
1.4	651.34	4822	1.50	43248					
1.3	716.06	5287	1.37	43248					
1.1	808.27	5964	1.22	43248					

NOTE
Other output speeds are available using 2 and 8 pole motors - Consult Textron Power Transmission

SERIES F

SELECTION TABLES

GEARED MOTORS

9608

	N2 R/MIN	i	M2 Nm	Fm	N	UNIT DESIGNATION	Kg	Motor Frame Size	SERIES X	MM	
	Output Speed	Ratio	Output Torque	Service Factor	Overhung Load	Column Entry 1 Through 20 Spaces to be filled when entering order	Weight of Base Mount Unit		Cone Ring Output Coupling Spaces to be filled when entering order	Max Bore Coupling Driven Half	
1.1 kW	4 POLE										
	270	5.11	37	4.80	4216	F 0 4 2 0 5 . 0 _ M _ - _ _ . 1 . 1 4 A _	35.8	90S	X 6 1 1 0 2 M 0 3 0 - _ _ _	42	
	218	6.32	46	4.40	4366	6 . 3					
	192	7.17	52	4.15	4476	7 . 1					
	175	7.90	58	3.96	4594	8 . 0					
	154	8.97	66	3.71	4752	9 . 0					
	141	9.77	72	3.60	4876	10 .					
	121	11.40	84	3.27	5048	11 .					
	107	12.95	95	3.06	5202	12 .			X 6 1 1 0 3 M 0 3 0 - _ _ _	48	
	98	14.09	104	2.95	5330	14 .					
	86	16.01	118	2.75	5484	16 .					
	78	17.63	130	2.57	5565	18 .					
	69	20.03	147	2.39	5712	20 .					
	63	21.79	160	2.26	5839	22 .					
	56	24.75	182	2.02	5981	25 .					
	48	28.82	212	1.32	6083	28 .					
	44	31.33	230	1.24	6114	32 .					
	39	35.62	263	1.32	6171	36 .					
	36	38.72	284	1.24	6164	40 .					
	31	45.14	333	0.88	6380	45 .					
	25	55.79	411	0.88	6460	56 .					
	22	63.92	465	0.81	5920	F 0 4 3 0 6 3 . _ M _ - _ _ . 1 . 1 4 A _	38.8	90S	X 6 1 1 0 4 M 0 3 0 - _ _ _	60	
	48	28.92	214	3.72	13706	F 0 6 2 0 2 8 . _ M _ - _ _ . 1 . 1 4 A _	60.8	90S	X 6 1 1 0 5 M 0 4 5 - _ _ _	70	
	45	30.88	228	3.54	13712	3 2 .					
	38	36.06	266	3.02	13788	3 6 .					
	36	38.50	284	2.83	13788	4 0 .					
	31	45.18	334	2.42	13845	4 5 .					
	28	49.47	366	2.21	13845	5 0 .					
	24	56.34	415	1.72	13947	5 6 .			X 6 1 1 0 4 M 0 4 5 - _ _ _	60	
	22	61.69	454	1.59	14475	6 3 .			X 6 1 1 0 5 M 0 4 5 - _ _ _	70	
	20	67.58	498	1.07	14828	7 1 .			X 6 1 1 0 4 M 0 4 5 - _ _ _	60	
	16	84.26	619	1.07	14828	9 0 .					
	22	63.48	464	1.75	14500	F 0 6 3 0 6 3 . _ M _ - _ _ . 1 . 1 4 A _	65.8	90S	X 6 1 1 0 5 M 0 4 5 - _ _ _	70	
	19	72.12	529	1.53	14433	7 1 .					
	17	79.15	578	1.39	14842	8 0 .					
	15	89.92	656	1.23	14842	9 0 .					
	13	103.79	755	1.07	13976	1 0 0					
	12	112.84	822	0.99	14800	1 1 2					
	11	129.41	942	0.85	14500	1 2 5					
	22	61.40	450	3.82	19044	F 0 7 2 0 6 3 . _ M _ - _ _ . 1 . 1 4 A _	88.8	90S	X 6 1 1 0 6 M 0 5 0 - _ _ _	80	
	20	68.02	498	1.87	19666	7 1 .			X 6 1 1 0 5 M 0 5 0 - _ _ _	70	
	18	75.58	554	1.38	19666	8 0 .					
	16	84.78	622	1.49	19666	9 0 .					
	15	94.20	689	1.34	19666	1 0 0					
	22	63.46	462	2.96	18866	F 0 7 3 0 6 3 . _ M _ - _ _ . 1 . 1 4 A _	98.8	90S	X 6 1 1 0 6 M 0 5 0 - _ _ _	80	
	19	73.81	540	2.68	18841	7 1 .					
	17	79.09	576	2.92	18942	8 0 .					
	15	91.99	669	2.51	18639	9 0 .					
	13	104.31	759	2.15	18713	1 0 0					
	12	111.37	812	2.04	19417	1 1 2					
	11	130.00	942	1.78	18993	1 2 5					
	10	138.80	1006	1.67	18710	1 4 0					
	8.5	162.96	1188	1.22	19273	1 6 0					
	7.7	178.44	1298	1.12	18776	1 8 0					
	6.8	203.11	1471	1.14	18208	2 0 0					
	6.2	222.40	1604	1.05	17569	2 2 5					
	5.7	243.74	1763	0.84	18400	2 5 0					
	18	77.20	565	3.20	24000	F 0 8 2 0 8 0 . _ M _ - _ _ . 1 . 1 4 A _	134.8	90S	X 6 1 1 0 6 M 0 6 0 - _ _ _	80	
	15	94.71	693	3.20	23822	1 0 0					
	13	103.32	752	3.69	23600	F 0 8 3 0 1 0 0 _ M _ - _ _ . 1 . 1 4 A _	139.8	90S	X 6 1 1 0 7 M 0 6 0 - _ _ _	90	
	12	116.63	850	3.27	23600	1 1 2					
	11	126.77	921	3.03	23520	1 2 5					
	10	143.09	1036	2.69	23233	1 4 0					
	8.4	164.88	1198	2.32	22971	1 6 0					
	7.6	181.11	1316	2.11	22657	1 8 0					
	6.8	202.29	1465	1.90	22833	2 0 0					
	6.2	222.21	1612	1.73	22400	2 2 5					
	5.7	242.37	1755	1.58	21766	2 5 0					
	4.9	279.09	2020	1.38	21573	2 8 0					
	4.6	297.37	2149	1.30	21400	3 1 5					
	4.0	342.42	2480	1.12	20357	3 5 5					
	4.0	344.74	2472	0.95	20998	F 0 8 4 0 3 6 0 _ M _ - _ _ . 1 . 1 4 A _	157.8	90S	X 6 1 1 0 7 M 0 6 0 - _ _ _	90	
	3.4	400.96	2874	0.82	20998	4 0 0					
	9.4	147.03	1067	3.95	33084	F 0 9 3 0 1 4 0 _ M _ - _ _ . 1 . 1 4 A _	199.8	90S	X 6 1 1 0 8 M 0 7 0 - _ _ _	100	
	8.6	160.82	1169	3.69	33084	1 6 0					
	7.8	177.54	1293	3.33	33068	1 8 0					
	6.6	207.69	1508	2.80	33052	2 0 0					
	6.0	229.28	1668	2.54	33055	2 2 5					
	5.7	244.23	1772	2.43	33055	2 5 0					
	5.0	274.63	1992	2.16	33032	2 8 0					
	4.4	315.41	2284	1.85	33033	3 1 5					
	3.9	354.67	2573	1.64	33033	3 5 5					

NOTE
Other output speeds are available using 2 and 8 pole motors - Consult Textron Power Transmission

SERIES F

SELECTION TABLES

GEARED MOTORS

9608

	N2 R/MIN	i	M2 Nm	Fm	N	UNIT DESIGNATION	Kg	Motor Frame Size	SERIES X	MM	
	Output Speed	Ratio	Output Torque	Service Factor	Overhung Load	Column Entry 1 Through 20 Spaces to be filled when entering order	Weight of Base Mount Unit		Cone Ring Output Coupling Spaces to be filled when entering order	Max Bore Coupling Driven Half	
1.1 kW	4 POLE										
	3.8	358.73	2579	1.64	32924	F 0 9 4 0 3 6 0 _ M _ - _ _ 1 . 1 4 A _	230.8	90S	X 6 1 1 0 8 M 0 7 0 - _ _ _	100	
	3.3	412.21	2962	1.43	32924	4 0 0					
	3.0	457.90	3276	1.29	32924	4 5 0					
	2.6	526.17	3762	1.12	32924	5 0 0					
	2.3	590.45	4235	1.00	32924	5 6 0					
	2.1	667.58	4784	0.88	32924	6 3 0					
	5.4	253.86	1849	3.46	43468	F 1 0 3 0 2 5 0 _ M _ - _ _ 1 . 1 4 A _	293.8	90S	X 6 1 1 0 9 M 0 9 0 - _ _ _	120	
	5.1	272.75	1983	3.23	43452	2 8 0					
	4.3	319.79	2321	3.12	43436	3 1 5					
	4.0	343.57	2486	2.92	43436	3 5 5					
	2.4	577.03	4146	1.75	43248	F 1 0 4 0 5 6 0 _ M _ - _ _ 1 . 1 4 A _	353.8	90S	X 6 1 1 0 9 M 0 9 0 - _ _ _	120	
	2.1	651.34	4677	1.55	43248	6 3 0					
	1.9	716.06	5131	1.41	43248	7 1 0					
	1.7	808.27	5788	1.25	43248	8 0 0					
6 POLE	180	5.11	56	3.62	4566	F 0 4 2 0 5 . 0 _ M _ - _ _ 1 . 1 6 A _	40.5	90L	X 6 1 1 0 2 M 0 3 0 - _ _ _	42	
	146	6.32	70	3.32	4843	6 . 3					
	128	7.17	79	3.13	4979	7 . 1					
	116	7.90	87	2.99	5099	8 . 0					
	103	8.97	99	2.80	5251	9 . 0			X 6 1 1 0 3 M 0 3 0 - _ _ _	48	
	94	9.77	108	2.71	5379	1 0 .					
	81	11.40	126	2.47	5537	1 1 .					
	71	12.95	143	2.31	5686	1 2 .					
	65	14.09	156	2.22	5812	1 4 .					
	57	16.01	177	2.06	5950	1 6 .					
	52	17.63	195	1.93	6006	1 8 .					
	46	20.03	222	1.70	6123	2 0 .					
	42	21.79	241	1.57	6241	2 2 .					
	37	24.75	273	1.40	6300	2 5 .					
	32	28.82	317	0.89	6360	2 8 .					
	29	31.33	344	0.88	6380	3 2 .					
	26	35.62	391	0.89	6490	3 6 .					
	24	38.72	426	0.88	6290	4 0 .					
	52	17.59	195	3.07	13388	F 0 6 2 0 1 8 . _ M _ - _ _ 1 . 1 6 A _	65.5	90L	X 6 1 1 0 4 M 0 4 5 - _ _ _	60	
	45	20.46	227	2.89	13712	2 0 .					
	42	21.94	243	3.07	13788	2 2 .			X 6 1 1 0 5 M 0 4 5 - _ _ _	70	
	36	25.51	283	2.84	13788	2 5 .					
	32	28.92	321	2.48	13811	2 8 .					
	30	30.88	343	2.36	13811	3 2 .					
	26	36.06	400	2.01	14381	3 6 .					
	24	38.50	427	1.88	14428	4 0 .					
	20	45.18	500	1.62	14334	4 5 .					
	19	49.47	547	1.48	14828	5 0 .					
	16	56.34	624	1.25	14828	5 6 .					
	15	61.69	683	1.16	14686	6 3 .					
	14	63.48	699	1.16	14383	F 0 6 3 0 6 3 . _ M _ - _ _ 1 . 1 6 A _	70.5	90L	X 6 1 1 0 5 M 0 4 5 - _ _ _	70	
	13	72.12	795	1.02	14800	7 1 .					
	12	79.15	864	0.93	14800	8 0 .					
	10	89.92	985	0.82	14200	9 0 .					
	23	40.55	448	3.83	18860	F 0 7 2 0 4 0 . _ M _ - _ _ 1 . 1 6 A _	93.5	90L	X 6 1 1 0 6 M 0 5 0 - _ _ _	80	
20	44.99	497	3.34	19394	4 5 .						
19	49.27	542	2.89	19450	5 0 .						
16	56.07	618	2.78	19533	5 6 .						
15	61.40	676	2.54	19311	6 3 .						
14	68.02	747	1.25	19635	7 1 .			X 6 1 1 0 5 M 0 5 0 - _ _ _	70		
12	75.58	827	0.92	19635	8 0 .						
11	84.78	927	1.09	19635	9 0 .						
10	94.20	1028	0.92	19635	1 0 0			X 6 1 2 0 6 M 0 5 0 - _ _ _	80		
14	63.46	696	2.17	18985	F 0 7 3 0 6 3 . _ M _ - _ _ 1 . 1 6 A _	103.5	90L	X 6 1 1 0 6 M 0 5 0 - _ _ _	80		
12	73.81	808	2.00	18475	7 1 .						
12	79.09	864	1.94	18372	8 0 .						
10	91.99	1004	1.67	18663	9 0 .						
8.8	104.31	1140	1.45	17815	1 0 0						
8.3	111.37	1221	1.36	19060	1 1 2						
7.1	130.00	1417	1.18	18421	1 2 5						
6.6	138.80	1518	1.11	17995	1 4 0						
5.6	162.96	1778	0.89	18200	1 6 0						
5.2	178.44	1947	0.82	17400	1 8 0						
18	50.09	553	3.63	23803	F 0 8 2 0 5 0 . _ M _ - _ _ 1 . 1 6 A _	139.5	90L	X 6 1 1 0 6 M 0 6 0 - _ _ _	80		
15	61.46	677	3.63	23604	6 3 .			X 6 1 1 0 7 M 0 6 0 - _ _ _	90		
14	67.04	739	3.26	23654	7 1 .			X 6 1 1 0 6 M 0 6 0 - _ _ _	80		
12	77.20	849	2.25	23700	8 0 .						
11	82.25	907	3.08	23645	9 0 .			X 6 1 1 0 7 M 0 6 0 - _ _ _	90		
10	94.71	1041	2.25	23228	1 0 0			X 6 1 1 0 6 M 0 6 0 - _ _ _	80		

NOTE
Other output speeds are available using 2 and 8 pole motors - Consult Textron Power Transmission

SERIES F

SELECTION TABLES

GEARED MOTORS

9608

1.1 kW	N2 R/MIN	i	M2 Nm	Fm	N	UNIT DESIGNATION	Kg	SERIES X	MM					
	Output Speed	Ratio	Output Torque	Service Factor	Overhung Load	Column Entry 1 Through 20	Weight of Base Mount Unit	Motor Frame Size	Cone Ring Output Coupling Spaces to be filled when entering order	Max Bore Coupling Driven Half				
						Spaces to be filled when entering order								
6 POLE	8.9	103.32	1131	2.46	22757	F 0 8 3 0 1 0 0 _ M _ - _ _ 1 . 1 6 A _	144.5	90L	X 6 1 1 0 7 M 0 6 0 - _ _ _	90				
	7.9	116.63	1276	2.18	22285	1 1 2								
	7.3	126.77	1380	2.02	22118	1 2 5								
	6.4	143.09	1562	1.79	22107	1 4 0								
	5.6	164.88	1802	1.54	20990	1 6 0								
	5.1	181.11	1981	1.40	21340	1 8 0								
	4.5	202.29	2208	1.26	20823	2 0 0								
	4.1	222.21	2426	1.15	19984	2 2 5								
	3.8	242.37	2637	1.05	18692	2 5 0								
	3.3	279.09	3039	0.91	18000	2 8 0								
	3.1	297.37	3234	0.86	17700	3 1 5								
	9.4	98.32	1081	3.90	33057	F 0 9 2 0 1 0 0 _ M _ - _ _ 1 . 1 6 A _					194.5	90L	X 6 1 1 0 8 M 0 7 0 - _ _ _	100
	9.0	102.48	1121	3.84	33100	F 0 9 3 0 1 0 0 _ M _ - _ _ 1 . 1 6 A _	204.5	90L	X 6 1 1 0 8 M 0 7 0 - _ _ _	100				
	8.1	113.85	1246	3.46	33100	1 1 2								
	7.0	132.34	1445	2.92	33100	1 2 5								
	6.3	147.03	1607	2.63	33060	1 4 0								
	5.7	160.82	1760	2.45	33060	1 6 0								
	5.2	177.54	1940	2.22	33060	1 8 0								
	4.4	207.69	2268	1.86	33020	2 0 0								
	4.0	229.28	2502	1.69	33020	2 2 5								
	3.8	244.23	2659	1.62	32980	2 5 0								
	3.3	274.63	2998	1.44	33035	2 8 0								
	2.9	315.41	3443	1.23	32970	3 1 5								
	2.6	354.67	3853	1.10	32906	3 5 5								
	2.6	358.73	3858	1.09	32924	F 0 9 4 0 3 6 0 _ M _ - _ _ 1 . 1 6 A _	235.5	90L	X 6 1 1 0 8 M 0 7 0 - _ _ _	100				
	2.2	412.21	4431	0.95	32924	4 0 0								
	2.0	457.90	4897	0.86	32924	4 5 0								
	5.6	162.91	1787	3.58	43459	F 1 0 3 0 1 6 0 _ M _ - _ _ 1 . 1 6 A _	298.5	90L	X 6 1 1 0 9 M 0 9 0 - _ _ _	120				
	4.9	187.70	2057	3.11	43439	1 8 0								
	4.5	205.21	2243	3.23	43419	2 0 0								
	3.9	236.45	2576	2.81	43419	2 2 5								
	3.6	253.86	2772	2.31	43416	2 5 0								
	3.4	272.75	2974	2.15	43416	2 8 0								
	2.9	319.79	3481	2.08	43388	3 1 5								
	2.7	343.57	3731	1.94	43380	3 5 5								
	1.6	577.03	6201	1.17	43248	F 1 0 4 0 5 6 0 _ M _ - _ _ 1 . 1 6 A _					358.5	90L	X 6 1 1 0 9 M 0 9 0 - _ _ _	120
	1.4	651.34	6995	1.04	43248	6 3 0								
	1.3	716.06	7670	0.95	43248	7 1 0								
	1.1	808.27	8652	0.84	43248	8 0 0								
									X 6 1 1 1 0 M 0 9 0 - _ _ _	140				

NOTE
Other output speeds are available using 2 and 8 pole motors - Consult Textron Power Transmission

SERIES F

SELECTION TABLES

GEARED MOTORS

9608

	1.5 kW	N2 R/MIN	i	M2 Nm	Fm	N	UNIT DESIGNATION	Kg	SERIES X	MM	
		Output Speed	Ratio	Output Torque	Service Factor	Overhung Load	Column Entry 1 Through 20 Spaces to be filled when entering order	Weight of Base Mount Unit	Cone Ring Output Coupling Spaces to be filled when entering order	Max Bore Coupling Driven Half	
4 POLE		272	5.11	51	3.55	4105	F 0 4 2 0 5 . 0 _ M _ - _ _ 1 . 5 4 A _	38.0	X 6 1 1 0 2 M 0 3 0 - _ _ _	42	
		220	6.32	63	3.25	4233					
		194	7.17	71	3.07	4321					
		176	7.90	78	2.93	4422					
		155	8.97	89	2.74	4557					
		142	9.77	97	2.66	4669					
		122	11.40	113	2.42	4800					
		107	12.95	129	2.26	4920			X 6 1 1 0 3 M 0 3 0 - _ _ _	48	
		99	14.09	140	2.18	5032					
		87	16.01	160	2.03	5145					
		79	17.63	176	1.90	5184					
		69	20.03	200	1.76	5278					
		64	21.79	217	1.67	5380					
		56	24.75	247	1.49	5459					
		48	28.82	288	0.97	5460					
		44	31.33	311	0.91	5480					
		39	35.62	356	0.97	5560					
		36	38.72	385	0.91	5550					
		79	17.59	177	3.39	11589	F 0 6 2 0 1 8 . _ M _ - _ _ 1 . 5 4 A _	63.0	90L	X 6 1 1 0 4 M 0 4 5 - _ _ _	60
		68	20.46	205	3.20	12109					
		63	21.94	220	3.39	12404				X 6 1 1 0 5 M 0 4 5 - _ _ _	70
		54	25.51	255	3.14	12909					
		48	28.92	290	2.75	13219					
		45	30.88	309	2.61	13228					
		39	36.06	360	2.23	13335					
		36	38.50	385	2.09	13335					
		31	45.18	452	1.79	13414					
		28	49.47	495	1.64	13414					
		25	56.34	562	1.27	13558				X 6 1 1 0 4 M 0 4 5 - _ _ _	60
		23	61.69	615	1.18	14302				X 6 1 1 0 5 M 0 4 5 - _ _ _	70
		22	63.48	628	1.29	14209	F 0 6 3 0 6 3 . _ M _ - _ _ 1 . 5 4 A _	68.0	90L	X 6 1 1 0 5 M 0 4 5 - _ _ _	70
		19	72.12	716	1.13	14093					
		18	79.15	783	1.03	14800					
		15	89.92	888	0.91	14800					
		31	44.99	448	3.70	18586	F 0 7 2 0 4 5 . _ M _ - _ _ 1 . 5 4 A _	91.0	90L	X 6 1 1 0 6 M 0 5 0 - _ _ _	80
		28	49.27	492	3.17	18567					
		25	56.07	558	3.08	18606					
		23	61.40	610	2.82	18567					
		20	68.02	674	1.38	19642				X 6 1 1 0 5 M 0 5 0 - _ _ _	70
		18	75.58	750	1.02	19642					
		16	84.78	842	1.10	19642					
		15	94.20	933	0.99	19642					
		22	63.46	626	2.19	18526	F 0 7 3 0 6 3 . _ M _ - _ _ 1 . 5 4 A _	101.0	90L	X 6 1 1 0 6 M 0 5 0 - _ _ _	80
		19	73.81	731	1.98	18490					
		18	79.09	780	2.15	18632					
		15	91.99	906	1.85	18206					
		13	104.31	1028	1.58	18310					
		12	111.37	1100	1.51	19301					
		11	130.00	1276	1.32	18704					
		10	138.80	1362	1.23	18306					
		8.5	162.96	1609	0.90	19100					
		7.8	178.44	1757	0.83	18400					
		6.8	203.11	1991	0.84	17600					
		21	67.04	666	3.50	23529	F 0 8 2 0 7 1 . _ M _ - _ _ 1 . 5 4 A _	137.0	90L	X 6 1 1 0 6 M 0 6 0 - _ _ _	80
		18	77.20	765	2.36	23490					
		17	82.25	817	3.41	23548				X 6 1 1 0 7 M 0 6 0 - _ _ _	90
		15	94.71	938	2.36	23183				X 6 1 1 0 6 M 0 6 0 - _ _ _	80
		13	103.32	1018	2.73	22800	F 0 8 3 0 1 0 0 _ M _ - _ _ 1 . 5 4 A _	142.0	90L	X 6 1 1 0 7 M 0 6 0 - _ _ _	90
		12	116.63	1150	2.42	22800					
		11	126.77	1247	2.24	22662					
		10	143.09	1403	1.99	22166					
		8.4	164.88	1623	1.71	21714					
		7.7	181.11	1782	1.56	21171					
		6.9	202.29	1984	1.41	21475					
		6.3	222.21	2182	1.28	20727					
		5.7	242.37	2377	1.17	19633					
		5.0	279.09	2735	1.02	19300					
		4.7	297.37	2910	0.96	19000					
		4.1	342.42	3358	0.83	17200					
		12	113.85	1124	3.83	33100	F 0 9 3 0 1 1 2 _ M _ - _ _ 1 . 5 4 A _	202.0	90L	X 6 1 1 0 8 M 0 7 0 - _ _ _	100
		11	132.34	1299	3.25	33072					
		9.5	147.03	1444	2.92	33072					
		8.6	160.82	1583	2.72	33072					
		7.8	177.54	1751	2.46	33044					
		6.7	207.69	2042	2.07	33017					
		6.1	229.28	2259	1.87	33022					
		5.7	244.23	2400	1.80	33022					
		5.1	274.63	2697	1.60	32983					
		4.4	315.41	3092	1.37	32984					
		3.9	354.67	3483	1.21	32984					
		3.9	358.73	3492	1.21	32924	F 0 9 4 0 3 6 0 _ M _ - _ _ 1 . 5 4 A _	233.0	90L	X 6 1 1 0 8 M 0 7 0 - _ _ _	100
		3.4	412.21	4010	1.05	32924					
		3.0	457.90	4435	0.95	32924				X 6 1 1 0 9 M 0 7 0 - _ _ _	120
		2.6	526.17	5093	0.83	32924					
		8.5	162.91	1610	3.98	43458	F 1 0 3 0 1 6 0 _ M _ - _ _ 1 . 5 4 A _	296.0	90L	X 6 1 1 0 9 M 0 9 0 - _ _ _	120
		7.4	187.70	1854	3.45	43461					
		6.8	205.21	2018	3.59	43442					
		5.9	236.45	2324	3.12	43423					
		5.5	253.86	2503	2.56	43444					
		5.1	272.75	2684	2.38	43417					
		4.3	319.79	3142	2.31	43389					
		4.0	343.57	3366	2.15	43389					
		2.4	577.03	5613	1.29	43248	F 1 0 4 0 5 6 0 _ M _ - _ _ 1 . 5 4 A _	356.0	90L	X 6 1 1 0 9 M 0 9 0 - _ _ _	120
		2.1	651.34	6331	1.15	43248					
		1.9	716.06	6947	1.04	43248					
		1.7	808.27	7836	0.93	43248					

NOTE
Other output speeds are available using 2 and 8 pole motors - Consult Textron Power Transmission

SERIES F

SELECTION TABLES

GEARED MOTORS

9608

1.5 kW		N2 R/MIN	i	M2 Nm	Fm	N	UNIT DESIGNATION	Kg	SERIES X	MM
Output Speed	Ratio	Output Torque	Service Factor	Overhung Load	Column Entry 1 Through 20 Spaces to be filled when entering order		Weight of Base Mount Unit	Motor Frame Size	Cone Ring Output Coupling Spaces to be filled when entering order	Max Bore Coupling Driven Half
6 POLE										
186	5.11	74	2.74	4400	F 0 4 2 0 5 . 0	M _ _ _ 1 . 5 6 A _	44.2	100La	X 6 1 1 0 2 M 0 3 0 - _ _ _	42
150	6.32	92	2.51	4641	6 . 3					
132	7.17	105	2.37	4743	7 . 1					
120	7.90	115	2.26	4841	8 . 0					
106	8.97	131	2.12	4956	9 . 0				X 6 1 1 0 3 M 0 3 0 - _ _ _	48
97	9.77	143	2.05	5066	10 .					
83	11.40	167	1.87	5164	11 .					
73	12.95	189	1.75	5262	12 .					
67	14.09	206	1.68	5364	14 .					
59	16.01	234	1.56	5441	16 .					
54	17.63	258	1.46	5429	18 .					
47	20.03	293	1.29	5467	20 .					
44	21.79	319	1.19	5546	22 .					
38	24.75	361	1.06	5550	25 .					
67	14.09	207	3.82	12261	F 0 6 2 0 1 4 .	M _ _ _ 1 . 5 6 A _	69.2	100La	X 6 1 1 0 5 M 0 4 5 - _ _ _	70
59	15.97	234	3.41	12710	16 .					
54	17.59	258	2.32	12935	18 .				X 6 1 1 0 4 M 0 4 5 - _ _ _	60
46	20.46	300	2.19	13228	20 .					
43	21.94	322	2.32	13335	22 .					
37	25.51	374	2.15	13335	25 .				X 6 1 1 0 5 M 0 4 5 - _ _ _	70
33	28.92	424	1.88	13366	28 .					
31	30.88	453	1.79	13366	32 .					
26	36.06	528	1.52	14170	36 .					
25	38.50	564	1.42	14236	40 .					
21	45.18	660	1.23	14103	45 .					
19	49.47	723	1.12	14800	50 .					
17	56.34	824	0.95	14800	56 .					
15	61.69	902	0.88	14600	63 .					
15	63.48	924	0.88	14100	F 0 6 3 0 6 3 .	M _ _ _ 1 . 5 6 A _	74.2	100La	X 6 1 1 0 5 M 0 4 5 - _ _ _	70
33	28.77	420	3.78	18305	F 0 7 2 0 2 8 .	M _ _ _ 1 . 5 6 A _	97.2	100La	X 6 1 1 0 6 M 0 5 0 - _ _ _	80
29	32.53	475	3.49	18400	32 .					
26	35.86	523	3.29	18444	36 .					
23	40.55	592	2.90	18400	40 .					
21	44.99	656	2.53	19227	45 .					
19	49.27	716	2.19	19313	50 .					
17	56.07	817	2.10	19442	56 .					
15	61.40	892	1.93	19098	63 .					
14	68.02	986	0.94	19600	71 .				X 6 1 1 0 5 M 0 5 0 - _ _ _	70
11	84.78	1224	0.82	19600	90 .				X 6 1 1 0 6 M 0 5 0 - _ _ _	80
15	63.46	919	1.64	18693	F 0 7 3 0 6 3 .	M _ _ _ 1 . 5 6 A _	107.2	100La	X 6 1 1 0 6 M 0 5 0 - _ _ _	80
13	73.81	1067	1.52	17975	71 .					
12	79.09	1141	1.47	17831	80 .					
10	91.99	1326	1.27	18240	90 .					
9.1	104.31	1506	1.10	17046	10 0					
8.5	111.37	1612	1.03	18800	11 2					
7.3	130.00	1872	0.90	17900	12 5					
6.8	138.80	2005	0.84	17300	14 0					
29	32.26	471	3.98	23257	F 0 8 2 0 3 2 .	M _ _ _ 1 . 5 6 A _	143.2	100La	X 6 1 1 0 6 M 0 6 0 - _ _ _	80
24	39.58	577	3.98	23273	40 .					
21	45.60	664	3.17	23067	45 .					
19	50.09	730	2.75	23312	50 .					
17	55.95	813	3.17	23290	56 .				X 6 1 1 0 7 M 0 6 0 - _ _ _	90
15	61.46	894	2.75	23003	63 .					
14	67.04	976	2.47	23081	71 .				X 6 1 1 0 6 M 0 6 0 - _ _ _	80
12	77.20	1122	1.70	23153	80 .					
12	82.25	1198	2.33	23067	90 .				X 6 1 1 0 7 M 0 6 0 - _ _ _	90
10	94.71	1374	1.70	22422	10 0				X 6 1 1 0 6 M 0 6 0 - _ _ _	80
9.2	103.32	1494	1.86	21692	F 0 8 3 0 1 0 0	M _ _ _ 1 . 5 6 A _	148.2	100La	X 6 1 1 0 7 M 0 6 0 - _ _ _	90
8.1	116.63	1685	1.65	20961	11 2					
7.5	126.77	1822	1.53	20704	12 5					
6.6	143.09	2062	1.35	20686	14 0					
5.8	164.88	2380	1.17	18957	16 0					
5.2	181.11	2617	1.06	19500	18 0					
4.7	202.29	2916	0.96	18700	20 0					
4.3	222.21	3203	0.87	17400	22 5					
14	67.71	988	4.00	33077	F 0 9 2 0 7 1 .	M _ _ _ 1 . 5 6 A _	198.2	100La	X 6 1 1 0 8 M 0 7 0 - _ _ _	100
12	76.14	1107	3.31	33077	80 .					
11	87.44	1271	3.32	33055	90 .					
10	98.32	1427	2.96	33033	10 0					
9.3	102.48	1481	2.91	33100	F 0 9 3 0 1 0 0	M _ _ _ 1 . 5 6 A _	208.2	100La	X 6 1 1 0 8 M 0 7 0 - _ _ _	100
8.3	113.85	1645	2.62	33100	11 2					
7.2	132.34	1909	2.21	33100	12 5					
6.5	147.03	2123	1.99	33038	14 0					
5.9	160.82	2324	1.85	33038	16 0					
5.4	177.54	2561	1.68	33038	18 0					
4.6	207.69	2996	1.41	32976	20 0					
4.1	229.28	3305	1.28	32976	22 5					
3.9	244.23	3512	1.23	32914	25 0					
3.5	274.63	3959	1.09	33000	28 0					
3.0	315.41	4547	0.93	32900	31 5					
2.7	354.67	5088	0.83	32800	35 5				X 6 1 1 0 9 M 0 7 0 - _ _ _	120
2.6	358.73	5095	0.83	32924	F 0 9 4 0 3 6 0	M _ _ _ 1 . 5 6 A _	245.2	100La	X 6 1 1 0 9 M 0 7 0 - _ _ _	120
8.3	114.24	1655	3.87	43436	F 1 0 3 0 1 1 2	M _ _ _ 1 . 5 6 A _	302.2	100La	X 6 1 1 0 9 M 0 9 0 - _ _ _	120
7.3	129.50	1868	3.88	43433	12 5					
6.6	143.90	2077	3.49	43433	14 0					
5.8	162.91	2360	2.71	43437	16 0					
5.1	187.70	2717	2.36	43406	18 0					
4.6	205.21	2962	2.45	43375	20 0					
4.0	236.45	3402	2.13	43375	22 5					
3.7	253.86	3660	1.75	43371	25 0					
3.5	272.75	3927	1.63	43371	28 0					
3.0	319.79	4598	1.58	43328	31 5					
2.8	343.57	4928	1.47	43314	35 5					
2.6	360.95	5131	1.41	43248	F 1 0 4 0 3 6 0	M _ _ _ 1 . 5 6 A _	362.2	100La	X 6 1 1 0 9 M 0 9 0 - _ _ _	120
2.3	420.16	5971	1.21	43248	40 0					
2.1	447.92	6346	1.14	43248	45 0					
1.8	521.39	7385	0.98	43248	50 0					
1.6	577.03	8190	0.89	43248	56 0					

NOTE
Other output speeds are available using 2 and 8 pole motors - Consult Textron Power Transmision

SERIES F

SELECTION TABLES

GEARED MOTORS

9608

2.2 kW	N2 R/MIN	i	M2 Nm	Fm	N	UNIT DESIGNATION	Kg		SERIES X	MM
4 POLE	Output Speed	Ratio	Output Torque	Service Factor	Overhung Load	Column Entry 1 Through 20 Spaces to be filled when entering order	Weight of Base Mount Unit	Motor Frame Size	Cone Ring Output Coupling Spaces to be filled when entering order	Max Bore Coupling Driven Half
	276	5.11	73	2.45	3910	F 0 4 2 0 5 . 0 _ M _ _ _ 2 . 2 4 A _	44.0	100La	X 6 1 1 0 2 M 0 3 0 - _ _ _	42
223	6.32	91	2.25	4000	6 . 3					
197	7.17	103	2.12	4049	7 . 1					
178	7.90	114	2.02	4122	8 . 0					
157	8.97	129	1.90	4216	9 . 0					
144	9.77	141	1.84	4308	1 0 .					
124	11.40	164	1.67	4366	1 1 .					
109	12.95	187	1.56	4427	1 2 .			X 6 1 1 0 3 M 0 3 0 - _ _ _	48	
100	14.09	203	1.51	4510	1 4 .					
88	16.01	231	1.41	4553	1 6 .					
80	17.63	255	1.31	4516	1 8 .					
70	20.03	289	1.22	4518	2 0 .					
65	21.79	314	1.15	4577	2 2 .					
57	24.75	357	1.03	4544	2 5 .					
110	12.81	186	3.76	10300	F 0 6 2 0 1 2 . _ M _ _ _ 2 . 2 4 A _	69.0	100La	X 6 1 1 0 4 M 0 4 5 - _ _ _	60	
100	14.09	204	3.66	10585	1 4 .			X 6 1 1 0 5 M 0 4 5 - _ _ _	70	
88	15.97	231	3.33	10955	1 6 .					
80	17.59	256	2.35	11076	1 8 .			X 6 1 1 0 4 M 0 4 5 - _ _ _	60	
69	20.46	297	2.21	11506	2 0 .					
64	21.94	318	2.35	11798	2 2 .			X 6 1 1 0 5 M 0 4 5 - _ _ _	70	
55	25.51	369	2.17	12204	2 5 .					
49	28.92	419	1.90	12367	2 8 .					
46	30.88	448	1.81	12380	3 2 .					
39	36.06	521	1.54	12541	3 6 .					
37	38.50	556	1.45	12541	4 0 .					
31	45.18	654	1.24	12661	4 5 .					
28	49.47	716	1.13	12661	5 0 .					
25	56.34	812	0.88	12877	5 6 .					
23	61.69	890	0.81	14000	6 3 .					
22	63.48	908	0.89	13700	F 0 6 3 0 6 3 . _ M _ _ _ 2 . 2 4 A _	74.0	100La	X 6 1 1 0 5 M 0 4 5 - _ _ _	70	
56	25.04	361	3.84	16557	F 0 7 2 0 2 5 . _ M _ _ _ 2 . 2 4 A _	97.0	100La	X 6 1 1 0 6 M 0 5 0 - _ _ _	80	
49	28.77	415	3.44	17009	2 8 .					
43	32.53	471	3.18	17571	3 2 .					
39	35.86	518	3.09	17848	3 6 .					
35	40.55	585	2.85	17800	4 0 .					
31	44.99	648	2.56	17766	4 5 .					
29	49.27	711	2.19	17733	5 0 .					
25	56.07	807	2.13	17800	5 6 .					
23	61.40	882	1.95	17733	6 3 .					
21	68.02	975	0.95	19600	7 1 .			X 6 1 1 0 5 M 0 5 0 - _ _ _	70	
22	63.46	906	1.51	17930	F 0 7 3 0 6 3 . _ M _ _ _ 2 . 2 4 A _	107.0	100La	X 6 1 1 0 6 M 0 5 0 - _ _ _	80	
19	73.81	1058	1.37	17877	7 1 .					
18	79.09	1127	1.49	18091	8 0 .					
15	91.99	1310	1.28	17448	9 0 .					
14	104.31	1486	1.10	17605	1 0 0					
13	111.37	1591	1.04	19100	1 1 2					
11	130.00	1845	0.91	18200	1 2 5					
10	138.80	1969	0.85	17600	1 4 0					
31	45.60	657	3.21	22587	F 0 8 2 0 4 5 . _ M _ _ _ 2 . 2 4 A _	143.0	100La	X 6 1 1 0 6 M 0 6 0 - _ _ _	80	
28	50.09	721	2.78	22539	5 0 .					
25	55.95	803	3.21	22610	5 6 .			X 6 1 1 0 7 M 0 6 0 - _ _ _	90	
23	61.46	883	2.78	22539	6 3 .					
21	67.04	963	2.42	22666	7 1 .			X 6 1 1 0 6 M 0 6 0 - _ _ _	80	
18	77.20	1106	1.64	22600	8 0 .					
17	82.25	1182	2.36	22700	9 0 .			X 6 1 1 0 7 M 0 6 0 - _ _ _	90	
15	94.71	1357	1.64	22066	1 0 0			X 6 1 1 0 6 M 0 6 0 - _ _ _	80	
14	103.32	1472	1.89	21400	F 0 8 3 0 1 0 0 _ M _ _ _ 2 . 2 4 A _	148.0	100La	X 6 1 1 0 7 M 0 6 0 - _ _ _	90	
12	116.63	1663	1.67	21400	1 1 2					
11	126.77	1803	1.55	21160	1 2 5					
10	143.09	2029	1.37	20300	1 4 0					
8.6	164.88	2346	1.18	19514	1 6 0					
7.8	181.11	2577	1.08	18571	1 8 0					
7.0	202.29	2869	0.97	19100	2 0 0					
6.3	222.21	3156	0.88	17800	2 2 5					
5.8	242.37	3436	0.81	15900	2 5 0			X 6 1 1 0 8 M 0 6 0 - _ _ _	100	
21	67.71	975	3.69	33068	F 0 9 2 0 7 1 . _ M _ _ _ 2 . 2 4 A _	198.0	100La	X 6 1 1 0 8 M 0 7 0 - _ _ _	100	
19	76.14	1094	3.29	33052	8 0 .					
16	87.44	1257	3.35	33076	9 0 .					
14	98.32	1410	2.99	33052	1 0 0					
14	102.48	1461	2.95	33100	F 0 9 3 0 1 0 0 _ M _ _ _ 2 . 2 4 A _	208.0	100La	X 6 1 1 0 8 M 0 7 0 - _ _ _	100	
12	113.85	1625	2.65	33100	1 1 2					
11	132.34	1879	2.25	33052	1 2 5					
10	147.03	2089	2.02	33052	1 4 0					
8.8	160.82	2288	1.88	33052	1 6 0					
7.9	177.54	2532	1.70	33004	1 8 0					
6.8	207.69	2953	1.43	32956	2 0 0					
6.1	229.28	3266	1.30	32965	2 2 5					
5.8	244.23	3470	1.24	32965	2 5 0					
5.1	274.63	3900	1.11	32897	2 8 0					
4.5	315.41	4471	0.95	32900	3 1 5					
4.0	354.67	5036	0.84	32900	3 5 5					
3.9	358.73	5049	0.84	32924	F 0 9 4 0 3 6 0 _ M _ _ _ 2 . 2 4 A _	245.0	100La	X 6 1 1 0 9 M 0 7 0 - _ _ _	120	

NOTE
Other output speeds are available using 2 and 8 pole motors - Consult Textron Power Transmision

SERIES F

SELECTION TABLES

GEARED MOTORS

9608

2.2 kW	N2 R/MIN	i	M2 Nm	Fm	N	UNIT DESIGNATION	Kg		SERIES X	MM				
	Output Speed	Ratio	Output Torque	Service Factor	Overhung Load	Column Entry 1 Through 20 Spaces to be filled when entering order	Weight of Base Mount Unit	Motor Frame Size	Cone Ring Output Coupling Spaces to be filled when entering order	Max Bore Coupling Driven Half				
4 POLE	12	114.24	1632	3.92	43436	F 1 0 3 0 1 1 2 _ M _ _ _ 2 . 2 4 A _	302.0	100La	X 6 1 1 0 9 M 0 9 0 - _ _ _	120				
	11	129.50	1842	3.93	43436	1 2 5								
	10	143.90	2047	3.54	43428	1 4 0								
	8.7	162.91	2327	2.75	43428	1 6 0								
	7.5	187.70	2681	2.39	43433	1 8 0								
	6.9	205.21	2918	2.48	43400	2 0 0								
	6.0	236.45	3361	2.16	43366	2 2 5								
	5.6	253.86	3619	1.77	43404	2 5 0								
	5.2	272.75	3881	1.65	43356	2 8 0								
	4.4	319.79	4543	1.60	43308	3 1 5								
	4.1	343.57	4867	1.49	43308	3 5 5								
	3.9	360.95	5086	1.43	43248	F 1 0 4 0 3 6 0 _ M _ _ _ 2 . 2 4 A _					362.0	100La	X 6 1 1 0 9 M 0 9 0 - _ _ _	120
	3.4	420.16	5917	1.23	43248	4 0 0								
	3.1	447.92	6294	1.15	43248	4 5 0								
2.7	521.39	7323	0.99	43248	5 0 0									
2.4	577.03	8116	0.89	43248	5 6 0									
6 POLE	185	5.11	110	1.86	4110	F 0 4 2 0 5 . 0 _ M _ _ _ 2 . 2 6 A _	52.8	112M	X 6 1 1 0 2 M 0 3 0 - _ _ _	42				
	150	6.32	136	1.70	4290	6 . 3								
	132	7.17	155	1.61	4330	7 . 1								
	120	7.90	170	1.53	4390	8 . 0								
	105	8.97	194	1.44	4440	9 . 0								
	97	9.77	211	1.39	4520	1 0 .								
	83	11.40	246	1.27	4510	1 1 .								
	73	12.95	279	1.19	4520	1 2 .								
	67	14.09	305	1.14	4580	1 4 .								
	59	16.01	346	1.06	4550	1 6 .								
	54	17.63	380	0.99	4420	1 8 .								
	47	20.03	433	0.87	4320	2 0 .								
	43	21.79	470	0.81	4330	2 2 .								
	188	5.03	109	3.78	8984	F 0 6 2 0 5 . 0 _ M _ _ _ 2 . 2 6 A _					80.8	112M	X 6 1 1 0 3 M 0 4 5 - _ _ _ X 6 1 1 0 4 M 0 4 5 - _ _ _	48 60
	151	6.27	135	3.78	9522	6 . 3								
	134	7.07	153	3.51	9783	7 . 1								
	119	7.93	172	3.37	10079	8 . 0								
	106	8.90	193	3.02	10372	9 . 0								
	96	9.89	214	3.32	10733	1 0 .								
	84	11.30	245	2.92	10997	1 1 .								
	74	12.81	278	2.79	11323	1 2 .								
	67	14.09	305	2.59	11680	1 4 .								
	59	15.97	346	2.31	12035	1 6 .								
	54	17.59	381	1.57	12141	1 8 .								
	46	20.46	443	1.49	12380	2 0 .								
	43	21.94	474	1.57	12541	2 2 .								
	37	25.51	551	1.46	12541	2 5 .								
	33	28.92	625	1.28	12588	2 8 .								
	31	30.88	668	1.21	12588	3 2 .								
	26	36.06	778	1.03	13800	3 6 .								
	25	38.50	832	0.97	13900	4 0 .								
	21	45.18	974	0.83	13700	4 5 .								
	183	5.15	111	3.82	12016	F 0 7 2 0 5 . 0 _ M _ _ _ 2 . 2 6 A _	109.8	112M	X 6 1 1 0 4 M 0 5 0 - _ _ _	60				
	147	6.42	138	3.82	12678	6 . 3								
	132	7.14	154	3.82	13040	7 . 1								
	118	8.02	173	3.82	13414	8 . 0								
	107	8.81	190	3.82	13786	9 . 0								
	95	9.99	215	3.82	14361	1 0 .								
	82	11.51	248	3.82	14887	1 1 .								
	72	13.09	282	3.82	15429	1 2 .								
	66	14.35	309	3.82	15907	1 4 .								
	58	16.31	353	3.74	16442	1 6 .								
	54	17.48	378	3.19	16657	1 8 .								
	47	20.09	434	3.02	17226	2 0 .								
	43	21.79	470	3.17	17749	2 2 .								
	38	25.04	538	2.91	17672	2 5 .								
	33	28.77	620	2.56	17441	2 8 .								
29	32.53	701	2.37	17595	3 2 .									
26	35.86	771	2.23	17666	3 6 .									
23	40.55	873	1.97	17595	4 0 .									
21	44.99	968	1.71	18934	4 5 .									
19	49.27	1056	1.49	19073	5 0 .									
17	56.07	1205	1.43	19282	5 6 .									
15	61.40	1316	1.31	18725	6 3 .									
15	63.46	1355	1.11	18183	F 0 7 3 0 6 3 . _ M _ _ _ 2 . 2 6 A _	118.8	112M	X 6 1 1 0 6 M 0 5 0 - _ _ _	80					
13	73.81	1574	1.03	17100	7 1 .									
12	79.09	1683	1.00	16883	8 0 .									
10	91.99	1955	0.86	17500	9 0 .									
33	28.58	617	3.11	22415	F 0 8 2 0 2 8 . _ M _ _ _ 2 . 2 6 A _	150.8	112M	X 6 1 1 0 6 M 0 6 0 - _ _ _	80					
29	32.26	695	2.70	22364	3 2 .									
27	35.06	755	3.11	22467	3 6 .									
24	39.58	851	2.70	22390	4 0 .									
21	45.60	980	2.15	22056	4 5 .									
19	50.09	1077	1.87	22452	5 0 .									
17	55.95	1198	2.15	22416	5 6 .									
15	61.46	1318	1.87	21953	6 3 .									
14	67.04	1440	1.67	22078	7 1 .									
12	77.20	1654	1.15	22195	8 0 .									
11	82.25	1766	1.58	22055	9 0 .									
10	94.71	2027	1.15	21012	1 0 0									
NOTE Other output speeds are available using 2 and 8 pole motors - Consult Textron Power Transmission	15	63.46	1355	1.11	18183					F 0 7 3 0 6 3 . _ M _ _ _ 2 . 2 6 A _	118.8	112M	X 6 1 1 0 6 M 0 5 0 - _ _ _	80
	13	73.81	1574	1.03	17100					7 1 .				
	12	79.09	1683	1.00	16883	8 0 .								
	10	91.99	1955	0.86	17500	9 0 .								
	33	28.58	617	3.11	22415	F 0 8 2 0 2 8 . _ M _ _ _ 2 . 2 6 A _	150.8	112M	X 6 1 1 0 6 M 0 6 0 - _ _ _	80				
	29	32.26	695	2.70	22364	3 2 .								
	27	35.06	755	3.11	22467	3 6 .								
	24	39.58	851	2.70	22390	4 0 .								
	21	45.60	980	2.15	22056	4 5 .								
	19	50.09	1077	1.87	22452	5 0 .								
17	55.95	1198	2.15	22416	5 6 .									
15	61.46	1318	1.87	21953	6 3 .									
14	67.04	1440	1.67	22078	7 1 .									
12	77.20	1654	1.15	22195	8 0 .									
11	82.25	1766	1.58	22055	9 0 .									
10	94.71	2027	1.15	21012	1 0 0									
								X 6 1 1 0 7 M 0 6 0 - _ _ _	90					
								X 6 1 1 0 6 M 0 6 0 - _ _ _	80					
								X 6 1 1 0 7 M 0 6 0 - _ _ _	90					
								X 6 1 1 0 6 M 0 6 0 - _ _ _	80					

SERIES F

SELECTION TABLES

GEARED MOTORS

9608

2.2 kW	N2 R/MIN	i	M2 Nm	Fm	N	UNIT DESIGNATION	Kg	Motor Frame Size	SERIES X	MM
6 POLE	Output Speed	Ratio	Output Torque	Service Factor	Overhung Load	Column Entry 1 Through 20 Spaces to be filled when entering order	Weight of Base Mount Unit		Cone Ring Output Coupling Spaces to be filled when entering order	Max Bore Coupling Driven Half
	9.1	103.32	2203	1.26	19829	F 0 8 3 0 1 0 0 _ M _ _ _ 2 . 2 6 A _	155.8	112M	X 6 1 1 0 7 M 0 6 0 - _ _ _	90
8.1	116.63	2485	1.12	18646	1 1 2					
7.5	126.77	2687	1.04	18228	1 2 5					
6.6	143.09	3041	0.92	18200	1 4 0					
16	57.58	1239	3.41	33064	F 0 9 2 0 5 6 . _ M _ _ _ 2 . 2 6 A _	205.8	112M	X 6 1 1 0 8 M 0 7 0 - _ _ _	100	
15	63.56	1368	3.08	33064	6 3 .					
14	67.71	1456	2.71	33064	7 1 .					
12	76.14	1632	2.24	33064	8 0 .					
11	87.44	1875	2.25	33028	9 0 .					
10	98.32	2105	2.00	32992	1 0 0					
9.2	102.48	2184	1.97	33100	F 0 9 3 0 1 0 0 _ M _ _ _ 2 . 2 6 A _	215.8	112M	X 6 1 1 0 8 M 0 7 0 - _ _ _	100	
8.3	113.85	2426	1.78	33100	1 1 2					
7.1	132.34	2815	1.50	33100	1 2 5					
6.4	147.03	3130	1.35	33000	1 4 0					
5.9	160.82	3427	1.26	33000	1 6 0					
5.3	177.54	3777	1.14	33000	1 8 0					
4.6	207.69	4417	0.96	32900	2 0 0					
4.1	229.28	4873	0.87	32900	2 2 5					
3.9	244.23	5178	0.83	32800	2 5 0			X 6 1 1 0 9 M 0 7 0 - _ _ _	120	
13	74.39	1599	3.51	43488	F 1 0 2 0 8 0 . _ M _ _ _ 2 . 2 6 A _	289.8	112M	X 6 1 1 0 9 M 0 9 0 - _ _ _	120	
11	87.21	1871	3.87	43476	9 0 .					
10	93.70	2009	3.51	43465	1 0 0					
9.2	102.80	2197	2.91	43423	F 1 0 3 0 1 0 0 _ M _ _ _ 2 . 2 6 A _	309.8	112M	X 6 1 1 0 9 M 0 9 0 - _ _ _	120	
8.3	114.24	2440	2.62	43397	1 1 2					
7.3	129.50	2755	2.63	43392	1 2 5					
6.6	143.90	3062	2.37	43392	1 4 0					
5.8	162.91	3480	1.84	43399	1 6 0					
5.0	187.70	4006	1.60	43348	1 8 0					
4.6	205.21	4367	1.66	43298	2 0 0					
4.0	236.45	5016	1.45	43298	2 2 5					
3.7	253.86	5397	1.19	43291	2 5 0					
3.5	272.75	5790	1.11	43291	2 8 0					
3.0	319.79	6779	1.07	43221	3 1 5					
2.8	343.57	7265	1.00	43200	3 5 5					
2.6	360.95	7566	0.96	43248	F 1 0 4 0 3 6 0 _ M _ _ _ 2 . 2 6 A _	369.8	112M	X 6 1 1 0 9 M 0 9 0 - _ _ _	120	
2.2	420.16	8803	0.82	43248	4 0 0			X 6 1 1 1 0 M 0 9 0 - _ _ _	140	

NOTE

Other output speeds are available using 2 and 8 pole motors - Consult Textron Power Transmission

SERIES F

SELECTION TABLES

GEARED MOTORS

9608

	N2 R/MIN	i	M2 Nm	Fm	N	UNIT DESIGNATION	Kg	SERIES X	MM
	Output Speed	Ratio	Output Torque	Service Factor	Overhung Load	Column Entry 1 Through 20 Spaces to be filled when entering order	Weight of Base Mount Unit	Cone Ring Output Coupling Spaces to be filled when entering order	Max Bore Coupling Driven Half
4 POLE									
	278	5.11	99	1.81	3688	F 0 4 2 0 5 . 0 _ M _ - _ _ 3 . 0 4 A _	47.8	X 6 1 1 0 2 M 0 3 0 - _ _ _	42
	225	6.32	123	1.66	3733	6 . 3			
	198	7.17	140	1.57	3738	7 . 1			
	180	7.90	154	1.50	3778	8 . 0			
	158	8.97	175	1.40	3826	9 . 0			
	145	9.77	191	1.36	3895	1 0 .			
	125	11.40	222	1.23	3870	1 1 .			
	110	12.95	253	1.16	3864	1 2 .		X 6 1 1 0 3 M 0 3 0 - _ _ _	48
	101	14.09	275	1.11	3914	1 4 .			
	89	16.01	314	1.04	3876	1 6 .			
	81	17.63	345	0.97	3753	1 8 .			
	71	20.03	391	0.90	3650	2 0 .			
	65	21.79	426	0.85	3660	2 2 .			
	226	6.27	122	3.98	8570	F 0 6 2 0 6 . 3 _ M _ - _ _ 3 . 0 4 A _	72.8	X 6 1 1 0 4 M 0 4 5 - _ _ _	60
	201	7.07	139	3.72	8660	7 . 1			
	179	7.93	156	3.53	8782	8 . 0			
	160	8.90	174	3.33	9023	9 . 0			
	144	9.89	194	3.24	9341	1 0 .			
	126	11.30	222	2.96	9543	1 1 .			
	111	12.81	252	2.77	9863	1 2 .			
	101	14.09	276	2.70	10142	1 4 .		X 6 1 1 0 5 M 0 4 5 - _ _ _	70
	89	15.97	313	2.46	10448	1 6 .			
	81	17.59	346	1.73	10490	1 8 .		X 6 1 1 0 4 M 0 4 5 - _ _ _	60
	69	20.46	402	1.64	10816	2 0 .			
	65	21.94	430	1.73	11105	2 2 .		X 6 1 1 0 5 M 0 4 5 - _ _ _	70
	56	25.51	500	1.61	11398	2 5 .			
	49	28.92	567	1.40	11393	2 8 .			
	46	30.88	606	1.34	11411	3 2 .			
	39	36.06	706	1.14	11634	3 6 .			
	37	38.50	754	1.07	11634	4 0 .			
	31	45.18	886	0.91	11800	4 5 .			
	29	49.47	970	0.84	11800	5 0 .			
	99	14.35	280	3.92	13827	F 0 7 2 0 1 4 . _ M _ - _ _ 3 . 0 4 A _	100.8	X 6 1 2 0 6 M 0 5 0 - _ _ _	80
	87	16.31	317	3.66	14281	1 6 .			
	81	17.48	341	3.43	14446	1 8 .			
	71	20.09	393	3.15	14935	2 0 .		X 6 1 1 0 6 M 0 5 0 - _ _ _	80
	65	21.79	427	3.09	15369	2 2 .			
	57	25.04	489	2.84	15907	2 5 .			
	49	28.77	563	2.54	16238	2 8 .			
	44	32.53	639	2.35	16685	3 2 .			
	40	35.86	702	2.28	16950	3 6 .			
	35	40.55	793	2.11	16879	4 0 .			
	32	44.99	878	1.89	16829	4 5 .			
	29	49.27	963	1.62	16779	5 0 .			
	25	56.07	1093	1.57	16878	5 6 .			
	23	61.40	1194	1.44	16779	6 3 .			
	22	63.46	1227	1.12	17250	F 0 7 3 0 6 3 . _ M _ - _ _ 3 . 0 4 A _	110.8	X 6 1 1 0 6 M 0 5 0 - _ _ _	80
	19	73.81	1432	1.01	17176	7 1 .			
	18	79.09	1527	1.10	17473	8 0 .			
	15	91.99	1774	0.95	16582	9 0 .			
	14	104.31	2013	0.81	16800	1 0 0			
	50	28.58	557	3.43	19636	F 0 8 2 0 2 8 . _ M _ - _ _ 3 . 0 4 A _	146.8	X 6 1 1 0 6 M 0 6 0 - _ _ _	80
	44	32.26	630	2.98	20255	3 2 .			
	40	35.06	685	3.43	20761	3 6 .			
	36	39.58	771	2.98	21356	4 0 .			
	31	45.60	890	2.37	21562	4 5 .			
	28	50.09	977	2.06	21492	5 0 .			
	25	55.95	1088	2.37	21597	5 6 .		X 6 1 1 0 7 M 0 6 0 - _ _ _	90
	23	61.46	1196	2.06	21492	6 3 .			
	21	67.04	1304	1.79	21680	7 1 .		X 6 1 1 0 6 M 0 6 0 - _ _ _	80
	18	77.20	1498	1.21	21581	8 0 .			
	17	82.25	1600	1.74	21730	9 0 .		X 6 1 1 0 7 M 0 6 0 - _ _ _	90
	15	94.71	1838	1.21	20789	1 0 0		X 6 1 1 0 6 M 0 6 0 - _ _ _	80
	14	103.32	1994	1.39	19800	F 0 8 3 0 1 0 0 _ M _ - _ _ 3 . 0 4 A _	151.8	X 6 1 1 0 7 M 0 6 0 - _ _ _	90
	12	116.63	2252	1.23	19800	1 1 2			
	11	126.77	2441	1.14	19444	1 2 5			
	10	143.09	2748	1.02	18166	1 4 0			
	8.6	164.88	3177	0.87	17000	1 6 0			
	25	57.58	1124	3.75	33076	F 0 9 2 0 5 6 . _ M _ - _ _ 3 . 0 4 A _	201.8	X 6 1 1 0 8 M 0 7 0 - _ _ _	100
	22	63.56	1243	3.39	33053	6 3 .			
	21	67.71	1320	2.73	33053	7 1 .			
	19	76.14	1482	2.43	33029	8 0 .			
	16	87.44	1703	2.48	33064	9 0 .			
	14	98.32	1909	2.21	33029	1 0 0			
	14	102.48	1979	2.18	33100	F 0 9 3 0 1 0 0 _ M _ - _ _ 3 . 0 4 A _	211.8	X 6 1 1 0 8 M 0 7 0 - _ _ _	100
	12	113.85	2200	1.96	33100	1 1 2			
	11	132.34	2544	1.66	33028	1 2 5			
	10	147.03	2828	1.49	33028	1 4 0			
	8.8	160.82	3099	1.39	33028	1 6 0			
	8.0	177.54	3429	1.26	32957	1 8 0			
	6.8	207.69	3999	1.06	32886	2 0 0			
	6.2	229.28	4422	0.96	32900	2 2 5			
	5.8	244.23	4698	0.92	32900	2 5 0			
	5.2	274.63	5281	0.82	32800	2 8 0		X 6 1 1 0 9 M 0 7 0 - _ _ _	120

NOTE
Other output speeds are available using 2 and 8 pole motors - Consult Textron Power Transmission

SERIES F

SELECTION TABLES

GEARED MOTORS

9608

3.0 kW	N2 R/MIN	i	M2 Nm	Fm	N	UNIT DESIGNATION	Kg		SERIES X	MM
	Output Speed	Ratio	Output Torque	Service Factor	Overhung Load	Column Entry 1 Through 20 Spaces to be filled when entering order	Weight of Base Mount Unit	Motor Frame Size	Cone Ring Output Coupling Spaces to be filled when entering order	Max Bore Coupling Driven Half
4 POLE	19	74.39	1456	3.85	43481	F 1 0 2 0 8 0 . . M _ - _ . 3 . 0 4 A _	285.8	100Lb	X 6 1 1 0 9 M 0 9 0 - _ _ _	120
	15	93.70	1827	3.85	43475	1 0 0				
	14	102.80	1989	3.20	43429	F 1 0 3 0 1 0 0 . M _ - _ . 3 . 0 4 A _	305.8	100Lb	X 6 1 1 0 9 M 0 9 0 - _ _ _	120
	12	114.24	2210	2.90	43406	1 1 2				
	11	129.50	2495	2.91	43406	1 2 5				
	10	143.90	2772	2.61	43394	1 4 0				
	8.7	162.91	3152	2.03	43394	1 6 0				
	7.6	187.70	3630	1.76	43401	1 8 0				
	6.9	205.21	3951	1.83	43351	2 0 0				
	6.0	236.45	4551	1.59	43302	2 2 5				
	5.6	253.86	4901	1.31	43357	2 5 0				
	5.2	272.75	5256	1.22	43286	2 8 0				
	4.4	319.79	6152	1.18	43215	3 1 5				
	4.1	343.57	6590	1.10	43215	3 5 5				
	3.9	360.95	6886	1.05	43248	F 1 0 4 0 3 6 0 . M _ - _ . 3 . 0 4 A _	365.8	100Lb	X 6 1 1 0 9 M 0 9 0 - _ _ _	120
3.4	420.16	8013	0.91	43248	4 0 0					
3.2	447.92	8522	0.85	43248	4 5 0					
6 POLE	189	5.03	147	2.78	8729	F 0 6 2 0 5 . 0 M _ - _ . 3 . 0 6 A _	91.0	132Sa	X 6 1 1 0 3 M 0 4 5 - _ _ _	48
	151	6.27	184	2.78	9225	6 . 3				
	134	7.07	208	2.59	9425	7 . 1				
	120	7.93	233	2.49	9677	8 . 0				
	107	8.90	262	2.22	9923	9 . 0				
	96	9.89	290	2.45	10267	1 0 .				
	84	11.30	333	2.15	10428	1 1 .				
	74	12.81	377	2.06	10677	1 2 .				
	67	14.09	414	1.91	11016	1 4 .				
	59	15.97	469	1.71	11264	1 6 .				
	54	17.59	517	1.16	11234	1 8 .				
	46	20.46	601	1.10	11411	2 0 .				
	43	21.94	644	1.16	11634	2 2 .				
	37	25.51	748	1.08	11634	2 5 .				
	33	28.92	848	0.94	11700	2 8 .				
	31	30.88	907	0.89	11700	3 2 .				
	184	5.15	150	2.81	11806	F 0 7 2 0 5 . 0 M _ - _ . 3 . 0 6 A _	120.0	132Sa	X 6 1 1 0 4 M 0 5 0 - _ _ _	60
	148	6.42	187	2.81	12424	6 . 3				
	133	7.14	208	2.81	12744	7 . 1				
	119	8.02	234	2.81	13088	8 . 0				
	108	8.81	258	2.81	13427	9 . 0				
	95	9.99	292	2.81	13973	1 0 .				
	83	11.51	337	2.81	14415	1 1 .				
	73	13.09	383	2.81	14892	1 2 .				
	66	14.35	419	2.81	15345	1 4 .				
	58	16.31	479	2.75	15804	1 6 .				
	54	17.48	513	2.36	15939	1 8 .				
	47	20.09	589	2.22	16407	2 0 .				
	44	21.79	638	2.34	16896	2 2 .				
	38	25.04	731	2.15	16785	2 5 .				
	33	28.77	841	1.89	16453	2 8 .				
	29	32.53	951	1.74	16675	3 2 .				
	26	35.86	1047	1.64	16777	3 6 .				
	23	40.55	1185	1.45	16675	4 0 .				
	21	44.99	1313	1.26	18600	4 5 .				
19	49.27	1433	1.10	18800	5 0 .					
17	56.07	1634	1.05	19100	5 6 .					
15	61.40	1785	0.96	18300	6 3 .					
15	63.46	1838	0.82	17600	F 0 7 3 0 6 3 . M _ - _ . 3 . 0 6 A _	129.0	132Sa	X 6 1 1 0 6 M 0 5 0 - _ _ _	80	
53	17.88	526	3.89	19384	F 0 8 2 0 1 8 . M _ - _ . 3 . 0 6 A _					
46	20.81	611	3.53	20094	2 0 .					
43	21.93	644	3.89	20478	2 2 .					
37	25.53	746	3.50	21257	2 5 .					
33	28.58	837	2.29	21417	2 8 .					
29	32.26	943	1.99	21343	3 2 .					
27	35.06	1025	2.29	21490	3 6 .					
24	39.58	1154	1.99	21380	4 0 .					
21	45.60	1329	1.59	20900	4 5 .					
19	50.09	1461	1.38	21470	5 0 .					
17	55.95	1626	1.59	21418	5 6 .					
15	61.46	1788	1.38	20752	6 3 .					
14	67.04	1953	1.23	20932	7 1 .					
12	77.20	2244	0.85	21100	8 0 .					
12	82.25	2396	1.16	20900	9 0 .					
10	94.71	2749	0.85	19400	1 0 0					
9.2	103.32	2988	0.93	17700	F 0 8 3 0 1 0 0 . M _ - _ . 3 . 0 6 A _	166.0	132Sa	X 6 1 1 0 7 M 0 6 0 - _ _ _	90	
8.1	116.63	3371	0.82	16000	1 1 2					
26	36.69	1075	3.93	33075	F 0 9 2 0 3 6 . M _ - _ . 3 . 0 6 A _	216.0	132Sa	X 6 1 1 0 8 M 0 7 0 - _ _ _	100	
23	40.76	1195	3.53	33050	4 0 .					
21	44.58	1306	3.30	33063	4 5 .					
19	49.22	1440	2.99	33063	5 0 .					
16	57.58	1681	2.51	33048	5 6 .					
15	63.56	1856	2.27	33048	6 3 .					
14	67.71	1976	2.00	33048	7 1 .					
12	76.14	2214	1.65	33048	8 0 .					
11	87.44	2543	1.66	32997	9 0 .					
10	98.32	2855	1.48	32946	1 0 0					

NOTE

Other output speeds are available using 2 and 8 pole motors - Consult Textron Power Transmission

SERIES F

SELECTION TABLES

GEARED MOTORS

9608

	N2 R/MIN	i	M2 Nm	Fm	N	UNIT DESIGNATION	Kg	SERIES X	MM	
4.0 kW	Output Speed	Ratio	Output Torque	Service Factor	Overhung Load	Column Entry 1 Through 20 Spaces to be filled when entering order	Weight of Base Mount Unit	Cone Ring Output Coupling Spaces to be filled when entering order	Max Bore Coupling Driven Half	
6 POLE	15	64.49	1878	3.86	43452	F 1 0 2 0 6 3 . . M _ - _ _ 3 . 0 6 A _	300.0	132Sa	X 6 1 1 0 9 M 0 9 0 - _ _ _	120
	14	69.24	2022	3.05	43452	7 1 .				
	13	74.39	2169	2.59	43475	8 0 .				
	11	87.21	2537	2.86	43450	9 0 .				
	10	93.70	2726	2.59	43425	1 0 0				
	9.2	102.80	2980	2.15	43389	F 1 0 3 0 1 0 0 _ M _ - _ _ 3 . 0 6 A _	320.0	132Sa	X 6 1 1 0 9 M 0 9 0 - _ _ _	120
	8.3	114.24	3310	1.93	43352	1 1 2				
	7.3	129.50	3737	1.94	43346	1 2 5				
	6.6	143.90	4154	1.74	43346	1 4 0				
	5.8	162.91	4720	1.36	43355	1 6 0				
	5.1	187.70	5434	1.18	43282	1 8 0				
	4.6	205.21	5924	1.22	43210	2 0 0				
	4.0	236.45	6804	1.07	43210	2 2 5				
	3.7	253.86	7321	0.87	43200	2 5 0				
	3.5	272.75	7855	0.81	43200	2 8 0				

NOTE

Other output speeds are available using 2 and 8 pole motors - Consult Textron Power Transmission

SERIES F

SELECTION TABLES

GEARED MOTORS

9608

4.0 kW	N2	i	M2	Fm	N	UNIT DESIGNATION	Kg	SERIES X	MM		
	R/MIN		Nm			Column Entry 1 Through 20					
	Output Speed	Ratio	Output Torque	Service Factor	Overhung Load	Spaces to be filled when entering order	Weight of Base Mount Unit	Motor Frame Size	Cone Ring Output Coupling Spaces to be filled when entering order	Max Bore Coupling Driven Half	
4 POLE	279	5.11	132	1.36	3410	F 0 4 2 0 5 . 0 _ M _ - _ - . 4 . 0 4 A _	55.0		42		
	225	6.32	163	1.25	3400	6 . 3					
	199	7.17	186	1.18	3350	7 . 1					
	180	7.90	205	1.13	3350	8 . 0					
	159	8.97	233	1.05	3340	9 . 0					
	146	9.77	254	1.02	3380	10 .					
	125	11.40	296	0.93	3250	11 .					
	110	12.95	336	0.87	3160	12 .					
	101	14.09	366	0.84	3170	14 .					
	283	5.03	131	3.14	8040	F 0 6 2 0 5 . 0 _ M _ - _ - . 4 . 0 4 A _				83.0	112M
	227	6.27	163	3.00	8321	6 . 3					
	201	7.07	185	2.80	8362	7 . 1					
	180	7.93	208	2.65	8448	8 . 0					
	160	8.90	232	2.51	8649	9 . 0					
	144	9.89	257	2.44	8949	10 .					
	126	11.30	295	2.23	9071	11 .					
	111	12.81	335	2.09	9318	12 .					
	101	14.09	367	2.03	9588	14 .					
	89	15.97	416	1.85	9815	16 .					
	81	17.59	460	1.30	9758	18 .					
70	20.46	535	1.23	9953	20 .						
65	21.94	572	1.30	10239	22 .						
56	25.51	665	1.21	10391	25 .						
49	28.92	754	1.06	10176	28 .						
46	30.88	806	1.00	10200	32 .						
40	36.06	938	0.86	10500	36 .						
37	38.50	1001	0.80	10500	40 .						
277	5.15	133	3.17	10883	F 0 7 2 0 5 . 0 _ M _ - _ - . 4 . 0 4 A _	112.0	112M	60 70 80 80			
222	6.42	165	3.17	11321	6 . 3						
200	7.14	185	3.17	11457	7 . 1						
178	8.02	208	3.17	11609	8 . 0						
162	8.81	229	3.17	11760	9 . 0						
143	9.99	259	3.17	12213	10 .						
124	11.51	299	3.17	12591	11 .						
109	13.09	340	3.02	12994	12 .						
99	14.35	373	2.95	13361	14 .						
87	16.31	421	2.75	13759	16 .						
82	17.48	453	2.58	13853	18 .						
71	20.09	522	2.37	14255	20 .						
65	21.79	567	2.32	14663	22 .						
57	25.04	651	2.14	15093	25 .						
50	28.77	748	1.91	15274	28 .						
44	32.53	849	1.77	15577	32 .						
40	35.86	932	1.71	15828	36 .						
35	40.55	1053	1.58	15728	40 .						
29	49.27	1280	1.22	15587	50 .						
25	56.07	1452	1.18	15727	56 .						
23	61.40	1587	1.08	15587	63 .						
22	63.46	1630	0.84	16400	F 0 7 3 0 6 3 . _ M _ - _ - . 4 . 0 4 A _	121.0	112M	80			
18	79.09	2029	0.83	16700	80 .						
80	17.88	464	3.98	16843	F 0 8 2 0 1 8 . _ M _ - _ - . 4 . 0 4 A _	153.0	112M	80 90 80 90 90			
68	20.81	543	3.59	17489	20 .						
65	21.93	568	3.96	17875	22 .						
56	25.53	666	3.59	18492	25 .						
50	28.58	740	2.58	18794	28 .						
44	32.26	838	2.24	19298	32 .						
41	35.06	910	2.58	19766	36 .						
36	39.58	1025	2.24	20237	40 .						
28	50.09	1298	1.55	20182	50 .						
25	55.95	1446	1.78	20331	56 .						
23	61.46	1589	1.55	20182	63 .						
21	67.04	1733	1.34	20448	71 .						
18	77.20	1991	0.91	20309	80 .						
17	82.25	2126	1.31	20518	90 .						
15	94.71	2442	0.91	19193	100 .						
14	103.32	2649	1.05	17800	F 0 8 3 0 1 0 0 _ M _ - _ - . 4 . 0 4 A _				158.0	112M	90
12	116.63	2993	0.93	17800	11 2						
11	126.77	3244	0.86	17300	12 5						
35	40.76	1060	3.98	33061	F 0 9 2 0 4 0 . _ M _ - _ - . 4 . 0 4 A _				208.0	112M	100
32	44.58	1161	3.71	33042	45 .						
29	49.22	1280	3.37	33052	50 .						
25	57.58	1493	2.83	33066	56 .						
22	63.56	1651	2.56	33033	63 .						
21	67.71	1754	2.05	33033	71 .						
19	76.14	1969	1.83	33000	80 .						
16	87.44	2262	1.86	33050	90 .						
14	98.32	2537	1.66	33000	100 .						
14	102.48	2630	1.64	33100	F 0 9 3 0 1 0 0 _ M _ - _ - . 4 . 0 4 A _	218.0	112M	100			
13	113.85	2923	1.47	33100	11 2						
11	132.34	3381	1.25	33000	12 5						
10	147.03	3758	1.12	33000	14 0						
8.9	160.82	4117	1.05	33000	16 0						
8.0	177.54	4556	0.95	32900	18 0						
21	69.24	1793	3.44	43455	F 1 0 2 0 7 1 . _ M _ - _ - . 4 . 0 4 A _				292.0	112M	120
19	74.39	1935	2.90	43457	80 .						
16	87.21	2252	3.22	43443	90 .						
15	93.70	2428	2.90	43443	100 .						
14	102.80	2642	2.41	43400	F 1 0 3 0 1 0 0 _ M _ - _ - . 4 . 0 4 A _	312.0	112M	120 140			
12	114.24	2936	2.18	43367	11 2						
11	129.50	3315	2.19	43367	12 5						
10	143.90	3683	1.97	43351	14 0						
8.7	162.91	4187	1.53	43351	16 0						
7.6	187.70	4823	1.33	43360	18 0						
6.9	205.21	5250	1.38	43290	20 0						
6.0	236.45	6046	1.20	43221	22 5						
5.6	253.86	6512	0.98	43300	25 0						
5.2	272.75	6983	0.92	43200	28 0						
4.5	319.79	8174	0.89	43100	31 5						
4.1	343.57	8756	0.83	43100	35 5						
								X 6 1 1 1 0 M 0 9 0 - _ _ _	140		

NOTE

Other output speeds are available using 2 and 8 pole motors - Consult Textron Power Transmission

SERIES F

SELECTION TABLES

GEARED MOTORS

9608

4.0 kW	N2 R/MIN	i	M2 Nm	Fm	N	UNIT DESIGNATION	Kg	SERIES X	MM	
6 POLE	Output Speed	Ratio	Output Torque	Service Factor	Overhung Load	Column Entry 1 Through 20 Spaces to be filled when entering order	Weight of Base Mount Unit	Motor Frame Size	Cone Ring Output Coupling Spaces to be filled when entering order	Max Bore Coupling Driven Half
	190	5.03	196	2.10	8409	F 0 6 2 0 5 . 0 _ M _ _ _ 4 . 0 6 A _	100.0	132Ma	X 6 1 1 0 3 M 0 4 5 - _ _ _	48
	152	6.27	244	2.10	8855	6 . 3			X 6 1 1 0 4 M 0 4 5 - _ _ _	60
	135	7.07	276	1.95	8979	7 . 1				
	120	7.93	309	1.88	9174	8 . 0				
	107	8.90	347	1.68	9362	9 . 0				
	97	9.89	385	1.85	9684	1 0 .				
	84	11.30	442	1.62	9717	1 1 .			X 6 1 1 0 5 M 0 4 5 - _ _ _	70
	75	12.81	500	1.55	9870	1 2 .				
	68	14.09	550	1.44	10185	1 4 .				
	60	15.97	622	1.29	10300	1 6 .				
	54	17.59	686	0.88	10100	1 8 .			X 6 1 1 0 4 M 0 4 5 - _ _ _	60
	47	20.46	798	0.83	10200	2 0 .			X 6 1 1 0 5 M 0 4 5 - _ _ _	70
	44	21.94	854	0.88	10500	2 2 .				
	37	25.51	992	0.81	10500	2 5 .				
	185	5.15	199	2.12	11544	F 0 7 2 0 5 . 0 _ M _ _ _ 4 . 0 6 A _	129.0	132Ma	X 6 1 1 0 4 M 0 5 0 - _ _ _	60
	149	6.42	248	2.12	12107	6 . 3				
	134	7.14	277	2.12	12373	7 . 1				
	119	8.02	311	2.12	12681	8 . 0				
	108	8.81	342	2.12	12978	9 . 0			X 6 1 1 0 5 M 0 5 0 - _ _ _	70
	96	9.99	387	2.12	13489	1 0 .				
	83	11.51	447	2.12	13826	1 1 .				
	73	13.09	509	2.12	14221	1 2 .			X 6 1 2 0 6 M 0 5 0 - _ _ _	80
	67	14.35	556	2.12	14642	1 4 .				
	59	16.31	635	2.08	15007	1 6 .			X 6 1 1 0 6 M 0 5 0 - _ _ _	80
	55	17.48	681	1.78	15041	1 8 .			X 6 1 2 0 6 M 0 5 0 - _ _ _	80
	48	20.09	781	1.68	15383	2 0 .			X 6 1 1 0 6 M 0 5 0 - _ _ _	80
	44	21.79	846	1.76	15830	2 2 .				
	38	25.04	969	1.62	15677	2 5 .				
	33	28.77	1115	1.43	15219	2 8 .				
	29	32.53	1261	1.32	15525	3 2 .				
	27	35.86	1388	1.24	15666	3 6 .				
	24	40.55	1571	1.09	15525	4 0 .				
	83	11.52	450	3.95	16710	F 0 8 2 0 1 1 . _ M _ _ _ 4 . 0 6 A _	170.0	132Ma	X 6 1 1 0 6 M 0 6 0 - _ _ _	80
	74	12.94	505	3.68	17226	1 2 .				
	68	14.14	547	3.85	17700	1 4 .				
	60	15.87	618	3.61	18189	1 6 .				
	53	17.88	698	2.93	18573	1 8 .				
	46	20.81	811	2.66	19157	2 0 .				
	44	21.93	855	2.93	19531	2 2 .			X 6 1 1 0 7 M 0 6 0 - _ _ _	90
	37	25.53	990	2.64	20163	2 5 .				
	33	28.58	1110	1.73	20168	2 8 .			X 6 1 1 0 6 M 0 6 0 - _ _ _	80
	30	32.26	1251	1.50	20067	3 2 .				
	27	35.06	1359	1.73	20270	3 6 .				
	24	39.58	1531	1.50	20117	4 0 .				
	19	50.09	1938	1.04	20242	5 0 .				
	17	55.95	2156	1.20	20171	5 6 .			X 6 1 1 0 7 M 0 6 0 - _ _ _	90
	16	61.46	2372	1.04	19251	6 3 .				
	14	67.04	2591	0.93	19500	7 1 .				
	34	28.41	1103	3.90	33075	F 0 9 2 0 2 8 . _ M _ _ _ 4 . 0 6 A _	225.0	132Ma	X 6 1 1 0 8 M 0 7 0 - _ _ _	100
	30	31.56	1229	3.51	33065	3 2 .				
	26	36.69	1425	2.96	33065	3 6 .				
	23	40.76	1585	2.66	33031	4 0 .				
	21	44.58	1733	2.49	33049	4 5 .				
	19	49.22	1910	2.26	33049	5 0 .				
	17	57.58	2229	1.89	33029	5 6 .				
	15	63.56	2462	1.71	33029	6 3 .				
	14	67.71	2620	1.51	33029	7 1 .				
	13	76.14	2937	1.25	33029	8 0 .				
	11	87.44	3373	1.25	32958	9 0 .				
	10	98.32	3787	1.11	32887	1 0 0				
	21	44.43	1727	3.71	43441	F 1 0 2 0 4 5 . _ M _ _ _ 4 . 0 6 A _	309.0	132Ma	X 6 1 1 0 9 M 0 9 0 - _ _ _	120
	19	51.19	1994	3.21	43444	5 0 .				
	17	55.97	2175	3.33	43425	5 6 .				
	15	64.49	2491	2.91	43421	6 3 .				
	14	69.24	2682	2.30	43421	7 1 .				
	13	74.39	2877	1.95	43458	8 0 .				
	11	87.21	3366	2.15	43416	9 0 .				
	10	93.70	3615	1.95	43375	1 0 0				
	9.3	102.80	3953	1.62	43347	F 1 0 3 0 1 0 0 _ M _ _ _ 4 . 0 6 A _	329.0	132Ma	X 6 1 1 0 9 M 0 9 0 - _ _ _	120
	8.4	114.24	4391	1.46	43296	1 1 2				
	7.4	129.50	4957	1.46	43287	1 2 5				
	6.6	143.90	5510	1.32	43287	1 4 0				
	5.9	162.91	6261	1.02	43300	1 6 0				
	5.1	187.70	7208	0.89	43200	1 8 0				
	4.7	205.21	7857	0.92	43100	2 0 0				
	4.0	236.45	9025	0.80	43100	2 2 5			X 6 1 1 1 0 M 0 9 0 - _ _ _	140

NOTE
Other output speeds are available using 2 and 8 pole motors - Consult Textron Power Transmission

SERIES F

SELECTION TABLES

GEARED MOTORS

9608

5.5 kW		N2 R/MIN	i	M2 Nm	Fm	N	UNIT DESIGNATION	Kg	SERIES X	MM
4 POLE	Output Speed	Ratio	Output Torque	Service Factor	Overhung Load	Column Entry 1 Through 20 Spaces to be filled when entering order	Weight of Base Mount Unit	Motor Frame Size	Cone Ring Output Coupling Spaces to be filled when entering order	Max Bore Coupling Driven Half
		288	5.03	177	2.33	7723	F 0 6 2 0 5 . 0 _ M _ _ _ 5 . 5 4 A _	94.0	132Sa	X 6 1 1 0 3 M 0 4 5 - _ _ _
	231	6.27	220	2.22	7947	6 . 3			X 6 1 1 0 4 M 0 4 5 - _ _ _	60
	205	7.07	250	2.07	7915	7 . 1				
	183	7.93	281	1.96	7947	8 . 0				
	163	8.90	313	1.85	8088	9 . 0				
	147	9.89	348	1.81	8362	10 .				
	128	11.30	399	1.65	8363	11 .				
	113	12.81	452	1.55	8500	12 .				
	103	14.09	496	1.50	8757	14 .			X 6 1 1 0 5 M 0 4 5 - _ _ _	70
	91	15.97	563	1.37	8866	16 .			X 6 1 1 0 4 M 0 4 5 - _ _ _	60
	82	17.59	622	0.97	8660	18 .			X 6 1 1 0 5 M 0 4 5 - _ _ _	70
	71	20.46	723	0.91	8660	20 .				
	66	21.94	773	0.97	8940	22 .				
	57	25.51	898	0.89	8880	25 .				
	281	5.15	179	2.35	10619	F 0 7 2 0 5 . 0 _ M _ _ _ 5 . 5 4 A _	123.0	132Sa	X 6 1 1 0 4 M 0 5 0 - _ _ _	60
	226	6.42	224	2.35	11006	6 . 3				
	203	7.14	250	2.35	11087	7 . 1				
	181	8.02	281	2.35	11200	8 . 0				
	165	8.81	309	2.35	11310	9 . 0			X 6 1 1 0 5 M 0 5 0 - _ _ _	70
	145	9.99	350	2.35	11724	10 .				
	126	11.51	404	2.35	12000	11 .				
	111	13.09	460	2.24	12322	12 .			X 6 1 2 0 6 M 0 5 0 - _ _ _	80
	101	14.35	504	2.18	12663	14 .				
	89	16.31	569	2.04	12975	16 .				
	83	17.48	612	1.91	12963	18 .				
	72	20.09	706	1.76	13236	20 .			X 6 1 1 0 6 M 0 5 0 - _ _ _	80
	67	21.79	767	1.72	13604	22 .				
	58	25.04	879	1.58	13873	25 .				
	50	28.77	1010	1.41	13828	28 .				
	45	32.53	1147	1.31	13915	32 .				
	40	35.86	1260	1.27	14144	36 .				
	36	40.55	1424	1.17	14002	40 .				
	32	44.99	1576	1.05	13900	45 .				
	29	49.27	1729	0.90	13800	50 .				
	26	56.07	1962	0.88	14000	56 .				
	24	61.40	2145	0.80	13800	63 .				
	126	11.52	406	3.96	14491	F 0 8 2 0 1 1 . _ M _ _ _ 5 . 5 4 A _	164.0	132Sa	X 6 1 1 0 6 M 0 6 0 - _ _ _	80
	112	12.94	455	3.69	14936	12 .				
	103	14.14	496	3.76	15359	14 .				
	91	15.87	558	3.53	15804	16 .				
	81	17.88	628	2.95	16046	18 .				
	70	20.81	734	2.65	16563	20 .				
	66	21.93	768	2.93	16937	22 .				
	57	25.53	900	2.65	17402	25 .				
	51	28.58	1000	1.91	17531	28 .				
	45	32.26	1132	1.66	17863	32 .				
	41	35.06	1230	1.91	18273	36 .				
	37	39.58	1385	1.66	18557	40 .				
	32	45.60	1598	1.32	18361	45 .				
	29	50.09	1754	1.15	18218	50 .				
	26	55.95	1954	1.32	18432	56 .			X 6 1 1 0 7 M 0 6 0 - _ _ _	90
	24	61.46	2147	1.15	18218	63 .				
	22	67.04	2342	0.99	18600	71 .			X 6 1 1 0 6 M 0 6 0 - _ _ _	80
	18	82.25	2873	0.97	18700	90 .			X 6 1 1 0 7 M 0 6 0 - _ _ _	90
	46	31.56	1112	3.87	33053	F 0 9 2 0 3 2 . _ M _ _ _ 5 . 5 4 A _	219.0	132Sa	X 6 1 1 0 8 M 0 7 0 - _ _ _	100
	40	36.69	1289	3.27	33030	36 .				
	36	40.76	1432	2.95	33044	40 .				
	33	44.58	1569	2.75	33017	45 .				
	29	49.22	1730	2.49	33031	50 .				
	25	57.58	2018	2.09	33052	56 .				
	23	63.56	2231	1.89	33005	63 .				
	21	67.71	2371	1.52	33005	71 .				
	19	76.14	2661	1.35	32957	80 .				
	17	87.44	3057	1.38	33028	90 .				
	15	98.32	3428	1.23	32957	100				
	28	51.19	1805	3.55	43450	F 1 0 2 0 5 0 . _ M _ _ _ 5 . 5 4 A _	303.0	132Sa	X 6 1 1 0 9 M 0 9 0 - _ _ _	120
	26	55.97	1964	3.69	43433	56 .				
	22	64.49	2265	3.20	43433	63 .				
	21	69.24	2423	2.55	43419	71 .				
	19	74.39	2614	2.15	43422	80 .				
	17	87.21	3043	2.38	43396	90 .				
	15	93.70	3281	2.15	43396	100				
	14	102.80	3571	1.78	43357	F 1 0 3 0 1 0 0 _ M _ _ _ 5 . 5 4 A _	323.0	132Sa	X 6 1 1 0 9 M 0 9 0 - _ _ _	120
	13	114.24	3968	1.61	43310	112				
	11	129.50	4480	1.62	43310	125				
	10	143.90	4978	1.46	43286	140				
	8.9	162.91	5659	1.13	43286	160				
	7.7	187.70	6518	0.98	43300	180				
	7.1	205.21	7095	1.02	43200	200				
	6.1	236.45	8171	0.89	43100	225				

NOTE
Other output speeds are available using 2 and 8 pole motors - Consult Textron Power Transmission

SERIES F

SELECTION TABLES

GEARED MOTORS

9608

	N2 R/MIN	i	M2 Nm	Fm	N	UNIT DESIGNATION	Kg	SERIES X	MM	
	Output Speed	Ratio	Output Torque	Service Factor	Overhung Load	Column Entry 1 Through 20 Spaces to be filled when entering order	Weight of Base Mount Unit	Cone Ring Output Coupling Spaces to be filled when entering order	Max Bore Coupling Driven Half	
6 POLE	191	5.03	268	1.53	7930	F 0 6 2 0 5 . 0 _ M _ - _ _ 5 . 5 6 A _	110.0	132Mb	X 6 1 1 0 3 M 0 4 5 - _ _ _	48
	153	6.27	334	1.53	8300	6 . 3			X 6 1 1 0 4 M 0 4 5 - _ _ _	60
	136	7.07	378	1.43	8310	7 . 1				
	121	7.93	423	1.37	8420	8 . 0				
	108	8.90	475	1.23	8520	9 . 0				
	97	9.89	527	1.35	8810	10 .				
	85	11.30	604	1.19	8650	11 .			X 6 1 1 0 5 M 0 4 5 - _ _ _	70
	75	12.81	685	1.13	8660	12 .				
	68	14.09	752	1.05	8940	14 .				
	186	5.15	273	1.55	11151	F 0 7 2 0 5 . 0 _ M _ - _ _ 5 . 5 6 A _	139.0	132Mb	X 6 1 1 0 4 M 0 5 0 - _ _ _	60
	150	6.42	339	1.55	11632	6 . 3				
	135	7.14	379	1.55	11817	7 . 1				
	120	8.02	426	1.55	12070	8 . 0				
	109	8.81	468	1.55	12306	9 . 0			X 6 1 1 0 5 M 0 5 0 - _ _ _	70
	96	9.99	530	1.55	12763	10 .				
	83	11.51	612	1.55	12942	11 .				
	73	13.09	696	1.55	13213	12 .			X 6 1 2 0 6 M 0 5 0 - _ _ _	80
	67	14.35	760	1.55	13587	14 .				
	59	16.31	869	1.52	13812	16 .			X 6 1 1 0 6 M 0 5 0 - _ _ _	80
	55	17.48	932	1.30	13695	18 .			X 6 1 2 0 6 M 0 5 0 - _ _ _	80
	48	20.09	1068	1.23	13847	20 .			X 6 1 1 0 6 M 0 5 0 - _ _ _	80
	44	21.79	1157	1.29	14231	22 .				
	38	25.04	1326	1.18	14015	25 .				
	33	28.77	1526	1.04	13368	28 .				
	30	32.53	1725	0.96	13800	32 .				
	27	35.86	1899	0.91	14000	36 .				
	24	40.55	2150	0.80	13800	40 .				
	189	5.09	269	3.16	13415	F 0 8 2 0 5 . 0 _ M _ - _ _ 5 . 5 6 A _	180.0	132Mb	X 6 1 1 0 5 M 0 6 0 - _ _ _	70
	154	6.24	331	3.16	13847	6 . 3			X 6 1 2 0 6 M 0 6 0 - _ _ _	80
	133	7.21	382	3.16	14294	7 . 1				
	120	8.01	426	3.16	14668	8 . 0			X 6 1 1 0 6 M 0 6 0 - _ _ _	80
	108	8.91	474	3.16	15100	9 . 0				
	98	9.83	521	3.16	15515	10 .				
	83	11.52	615	2.89	15936	11 .				
	74	12.94	691	2.69	16342	12 .				
	68	14.14	748	2.82	16800	14 .				
	60	15.87	845	2.64	17163	16 .				
	54	17.88	955	2.15	17357	18 .				
	46	20.81	1110	1.95	17752	20 .				
	44	21.93	1169	2.15	18110	22 .			X 6 1 1 0 7 M 0 6 0 - _ _ _	90
	38	25.53	1354	1.93	18521	25 .				
	34	28.58	1519	1.26	18296	28 .			X 6 1 1 0 6 M 0 6 0 - _ _ _	80
	30	32.26	1711	1.10	18152	32 .				
	27	35.06	1859	1.26	18440	36 .				
	24	39.58	2094	1.10	18224	40 .				
21	45.60	2412	0.87	17289	45 .					
17	55.95	2950	0.87	18300	56 .			X 6 1 1 0 7 M 0 6 0 - _ _ _	90	
34	28.41	1509	2.85	33064	F 0 9 2 0 2 8 . _ M _ - _ _ 5 . 5 6 A _	235.0	132Mb	X 6 1 1 0 8 M 0 7 0 - _ _ _	100	
30	31.56	1681	2.56	33051	32 .					
26	36.69	1950	2.16	33051	36 .					
24	40.76	2169	1.95	33003	40 .					
22	44.58	2370	1.82	33028	45 .					
20	49.22	2613	1.65	33028	50 .					
17	57.58	3049	1.38	33000	56 .					
15	63.56	3368	1.25	33000	63 .					
14	67.71	3584	1.10	33000	71 .					
13	76.14	4017	0.91	33000	80 .					
11	87.44	4614	0.91	32900	90 .					
10	98.32	5180	0.81	32800	10 0			X 6 1 1 0 9 M 0 7 0 - _ _ _	120	
31	31.16	1660	3.85	43460	F 1 0 2 0 3 2 . _ M _ - _ _ 5 . 5 6 A _	319.0	132Mb	X 6 1 1 0 9 M 0 9 0 - _ _ _	120	
27	35.32	1872	3.87	43441	36 .					
24	39.25	2087	3.47	43421	40 .					
22	44.43	2362	2.71	43405	45 .					
19	51.19	2728	2.35	43411	50 .					
17	55.97	2975	2.44	43381	56 .					
15	64.49	3408	2.13	43373	63 .					
14	69.24	3668	1.68	43373	71 .					
13	74.39	3935	1.43	43433	80 .					
11	87.21	4604	1.57	43366	90 .					
10	93.70	4945	1.43	43300	10 0					
9.3	102.80	5407	1.18	43284	F 1 0 3 0 1 0 0 _ M _ - _ _ 5 . 5 6 A _	339.0	132Mb	X 6 1 1 0 9 M 0 9 0 - _ _ _	120	
8.4	114.24	6006	1.07	43212	11 2					
7.4	129.50	6781	1.07	43200	12 5					
6.7	143.90	7537	0.96	43200	14 0					

NOTE
Other output speeds are available using 2 and 8 pole motors - Consult Textron Power Transmission

SERIES F

SELECTION TABLES

GEARED MOTORS

9608

7.5 kW	N2 R/MIN	i	M2 Nm	Fm	N	UNIT DESIGNATION	Kg		SERIES X	MM
4 POLE	Output Speed	Ratio	Output Torque	Service Factor	Overhung Load	Column Entry 1 Through 20 Spaces to be filled when entering order	Weight of Base Mount Unit	Motor Frame Size	Cone Ring Output Coupling Spaces to be filled when entering order	Max Bore Coupling Driven Half
	288	5.03	241	1.71	7300	F 0 6 2 0 5 . 0 _ M _ - _ _ 7 . 5 4 A _	104.0	132Ma	X 6 1 1 0 3 M 0 4 5 - _ _ _	48
231	6.27	300	1.63	7450	6 . 3			X 6 1 1 0 4 M 0 4 5 - _ _ _	60	
205	7.07	341	1.52	7320	7 . 1					
183	7.93	384	1.44	7280	8 . 0					
163	8.90	427	1.36	7340	9 . 0					
147	9.89	475	1.32	7580	1 0 .					
128	11.30	545	1.21	7420	1 1 .					
113	12.81	617	1.13	7410	1 2 .					
103	14.09	677	1.10	7650	1 4 .			X 6 1 1 0 5 M 0 4 5 - _ _ _	70	
91	15.97	767	1.00	7600	1 6 .					
281	5.15	245	1.72	10268	F 0 7 2 0 5 . 0 _ M _ - _ _ 7 . 5 4 A _	133.0	132Ma	X 6 1 1 0 4 M 0 5 0 - _ _ _	60	
226	6.42	305	1.72	10586	6 . 3					
203	7.14	341	1.72	10595	7 . 1					
181	8.02	383	1.72	10654	8 . 0					
165	8.81	422	1.72	10710	9 . 0			X 6 1 1 0 5 M 0 5 0 - _ _ _	70	
145	9.99	477	1.72	11073	1 0 .					
126	11.51	551	1.72	11213	1 1 .					
111	13.09	628	1.64	11427	1 2 .			X 6 1 2 0 6 M 0 5 0 - _ _ _	80	
101	14.35	687	1.60	11732	1 4 .					
89	16.31	776	1.49	11929	1 6 .					
83	17.48	835	1.40	11776	1 8 .					
72	20.09	962	1.29	11877	2 0 .			X 6 1 1 0 6 M 0 5 0 - _ _ _	80	
67	21.79	1046	1.26	12191	2 2 .					
58	25.04	1199	1.16	12246	2 5 .					
50	28.77	1378	1.04	11900	2 8 .					
45	32.53	1564	0.96	11700	3 2 .					
40	35.86	1719	0.93	11900	3 6 .					
36	40.55	1941	0.86	11700	4 0 .					
285	5.09	242	3.51	12313	F 0 8 2 0 5 . 0 _ M _ - _ _ 7 . 5 4 A _	174.0	132Ma	X 6 1 1 0 5 M 0 6 0 - _ _ _	70	
232	6.24	296	3.51	12747	6 . 3			X 6 1 2 0 6 M 0 6 0 - _ _ _	80	
201	7.21	345	3.51	12882	7 . 1					
181	8.01	384	3.51	13016	8 . 0			X 6 1 1 0 6 M 0 6 0 - _ _ _	80	
163	8.91	426	3.37	13192	9 . 0					
148	9.83	471	3.33	13450	1 0 .					
126	11.52	553	2.91	13819	1 1 .					
112	12.94	620	2.71	14171	1 2 .					
103	14.14	677	2.76	14546	1 4 .					
91	15.87	761	2.59	14898	1 6 .					
81	17.88	856	2.16	14984	1 8 .					
70	20.81	1001	1.95	15328	2 0 .					
66	21.93	1048	2.15	15687	2 2 .					
57	25.53	1227	1.95	15949	2 5 .					
51	28.58	1364	1.40	15847	2 8 .					
45	32.26	1544	1.22	15949	3 2 .					
41	35.06	1678	1.40	16283	3 6 .					
37	39.58	1889	1.22	16318	4 0 .					
32	45.60	2179	0.97	15800	4 5 .					
29	50.09	2392	0.84	15600	5 0 .					
26	55.95	2665	0.97	15900	5 6 .			X 6 1 1 0 7 M 0 6 0 - _ _ _	90	
24	61.46	2928	0.84	15600	6 3 .					
51	28.41	1363	3.16	33067	F 0 9 2 0 2 8 . _ M _ - _ _ 7 . 5 4 A _	229.0	132Ma	X 6 1 1 0 8 M 0 7 0 - _ _ _	100	
46	31.56	1517	2.84	33035	3 2 .					
40	36.69	1758	2.40	33002	3 6 .					
36	40.76	1953	2.16	33022	4 0 .					
33	44.58	2140	2.01	32983	4 5 .					
29	49.22	2359	1.83	33003	5 0 .					
25	57.58	2752	1.53	33033	5 6 .					
23	63.56	3043	1.39	32966	6 3 .					
21	67.71	3233	1.11	32966	7 1 .					
19	76.14	3629	0.99	32900	8 0 .					
17	87.44	4169	1.01	33000	9 0 .					
15	98.32	4675	0.90	32900	1 0 0					
41	35.32	1694	3.81	43439	F 1 0 2 0 3 6 . _ M _ - _ _ 7 . 5 4 A _	313.0	132Ma	X 6 1 1 0 9 M 0 9 0 - _ _ _	120	
37	39.25	1879	3.56	43439	4 0 .					
33	44.43	2133	3.00	43423	4 5 .					
28	51.19	2461	2.60	43419	5 0 .					
26	55.97	2678	2.71	43392	5 6 .					
22	64.49	3089	2.35	43392	6 3 .					
21	69.24	3305	1.87	43369	7 1 .					
19	74.39	3565	1.57	43375	8 0 .					
17	87.21	4150	1.75	43334	9 0 .					
15	93.70	4474	1.57	43334	1 0 0					
14	102.80	4870	1.31	43300	F 1 0 3 0 1 0 0 _ M _ - _ _ 7 . 5 4 A _	333.0	132Ma	X 6 1 1 0 9 M 0 9 0 - _ _ _	120	
13	114.24	5411	1.18	43233	1 1 2					
11	129.50	6109	1.19	43233	1 2 5					
10	143.90	6788	1.07	43200	1 4 0					
8.9	162.91	7717	0.83	43200	1 6 0					

NOTE
Other output speeds are available using 2 and 8 pole motors - Consult Textron Power Transmission

SERIES F

SELECTION TABLES

GEARED MOTORS

9608

	N2 R/MIN	i	M2 Nm	Fm	N	UNIT DESIGNATION	Kg	SERIES X	MM	
	Output Speed	Ratio	Output Torque	Service Factor	Overhung Load	Column Entry 1 Through 20 Spaces to be filled when entering order	Weight of Base Mount Unit	Cone Ring Output Coupling Spaces to be filled when entering order	Max Bore Coupling Driven Half	
6 POLE	187	5.15	370	1.14	10627	F 0 7 2 0 5 . 0 _ M _ - _ _ 7 . 5 6 A _	150.0	160M	60	
	150	6.42	460	1.14	10998	6 . 3				
	135	7.14	514	1.14	11076	7 . 1				
	120	8.02	578	1.14	11255	8 . 0				
	109	8.81	635	1.14	11409	9 . 0				
	97	9.99	719	1.14	11794	1 0 .				
	84	11.51	830	1.14	11763	1 1 .				
	74	13.09	944	1.14	11870	1 2 .				
	67	14.35	1032	1.14	12181	1 4 .				
	59	16.31	1179	1.12	12218	1 6 .				
	55	17.48	1264	0.96	11900	1 8 .				
	48	20.09	1450	0.90	11800	2 0 .				
	44	21.79	1570	0.95	12100	2 2 .				
	39	25.04	1799	0.87	11800	2 5 .				
		190	5.09	365	2.33	12973				F 0 8 2 0 5 . 0 _ M _ - _ _ 7 . 5 6 A _
	155	6.24	450	2.33	13321	6 . 3				
	134	7.21	518	2.33	13642	7 . 1				
	120	8.01	578	2.33	13952	8 . 0				
	108	8.91	643	2.33	14300	9 . 0				
	98	9.83	707	2.33	14673	1 0 .				
	84	11.52	835	2.13	14905	1 1 .				
	75	12.94	937	1.98	15163	1 2 .				
	68	14.14	1015	2.08	15600	1 4 .				
	61	15.87	1147	1.94	15794	1 6 .				
	54	17.88	1296	1.58	15736	1 8 .				
	46	20.81	1506	1.43	15878	2 0 .				
	44	21.93	1587	1.58	16215	2 2 .				
	38	25.53	1837	1.42	16331	2 5 .				
		34	28.58	2061	0.93	15800	2 8 .	251.0	160M	100
	30	32.26	2322	0.81	15600	3 2 .				
	28	35.06	2522	0.93	16000	3 6 .				
	24	39.58	2841	0.81	15700	4 0 .				
	76	12.68	916	3.87	33100	F 0 9 2 0 1 2 . _ M _ - _ _ 7 . 5 6 A _	337.0			
	66	14.66	1057	3.63	33100	1 4 .				
	59	16.37	1182	3.39	33100	1 6 .				
	55	17.58	1271	3.22	33100	1 8 .				
	48	20.04	1448	2.98	33100	2 0 .				
	43	22.70	1639	2.57	33100	2 2 .				
	37	25.88	1863	2.27	33100	2 5 .				
	34	28.41	2048	2.10	33051	2 8 .				
	31	31.56	2280	1.89	33032	3 2 .				
	26	36.69	2645	1.59	33032	3 6 .				
	24	40.76	2942	1.43	32965	4 0 .				
	22	44.58	3215	1.34	33000	4 5 .				
	20	49.22	3545	1.22	33000	5 0 .				
	47	20.46	1479	3.94	43500	F 1 0 2 0 2 0 . _ M _ - _ _ 7 . 5 6 A _		337.0	160M	120
42	22.76	1643	3.77	43500	2 2 .					
37	25.77	1859	3.48	43500	2 5 .					
34	28.04	2031	3.15	43415	2 8 .					
31	31.16	2252	2.84	43441	3 2 .					
27	35.32	2539	2.85	43412	3 6 .					
25	39.25	2832	2.56	43382	4 0 .					
22	44.43	3204	2.00	43358	4 5 .					
19	51.19	3701	1.73	43366	5 0 .					
17	55.97	4036	1.80	43322	5 6 .					
15	64.49	4623	1.57	43310	6 3 .					
14	69.24	4976	1.24	43310	7 1 .					
13	74.39	5338	1.05	43400	8 0 .					
11	87.21	6246	1.16	43300	9 0 .					
10	93.70	6709	1.05	43200	1 0 0					
	9.4	102.80	7335	0.87	43200	F 1 0 3 0 1 0 0 _ M _ - _ _ 7 . 5 6 A _	337.0	160M	120	

NOTE
Other output speeds are available using 2 and 8 pole motors - Consult Textron Power Transmission

SERIES F

SELECTION TABLES

GEARED MOTORS

9608

	N2 R/MIN	i	M2 Nm	Fm	N	UNIT DESIGNATION	Kg	SERIES X	MM					
	Output Speed	Ratio	Output Torque	Service Factor	Overhung Load	Column Entry 1 Through 20 Spaces to be filled when entering order	Weight of Base Mount Unit	Cone Ring Output Coupling Spaces to be filled when entering order	Max Bore Coupling Driven Half					
4 POLE	282	5.15	358	1.18	9653	F 0 7 2 0 5 . 0 _ M _ - _ _ 1 1 . 4 A _	155.0	160M	X 6 1 1 0 4 M 0 5 0 - _ _ _	60				
	227	6.42	446	1.18	9850	6 . 3								
	204	7.14	498	1.18	9734	7 . 1								
	182	8.02	560	1.18	9700	8 . 0								
	165	8.81	616	1.18	9660	9 . 0								
	146	9.99	698	1.18	9933	1 0 .								
	126	11.51	806	1.18	9835	1 1 .								
	111	13.09	917	1.12	9860	1 2 .								
	101	14.35	1004	1.09	10102	1 4 .								
	89	16.31	1135	1.02	10100	1 6 .								
	83	17.48	1221	0.96	9700	1 8 .								
	72	20.09	1407	0.88	9500	2 0 .								
	67	21.79	1529	0.86	9720	2 2 .								
	286	5.09	354	2.40	11793	F 0 8 2 0 5 . 0 _ M _ - _ _ 1 1 . 4 A _					194.0	160M	X 6 1 1 0 5 M 0 6 0 - _ _ _	70
	233	6.24	433	2.40	12118	6 . 3								
	202	7.21	504	2.40	12143	7 . 1								
	182	8.01	562	2.40	12168	8 . 0								
	163	8.91	623	2.31	12262	9 . 0								
	148	9.83	688	2.28	12493	1 0 .								
	126	11.52	809	1.99	12643	1 1 .								
	112	12.94	907	1.85	12831	1 2 .								
	103	14.14	990	1.89	13125	1 4 .								
	92	15.87	1113	1.77	13312	1 6 .								
	81	17.88	1251	1.48	13125	1 8 .								
	70	20.81	1464	1.33	13168	2 0 .								
	66	21.93	1531	1.47	13500	2 2 .								
	57	25.53	1794	1.33	13406	2 5 .								
	51	28.58	1994	0.96	12900	2 8 .								
	45	32.26	2257	0.83	12600	3 2 .								
	41	35.06	2453	0.96	12800	3 6 .								
	37	39.58	2761	0.83	12400	4 0 .								
	128	11.35	797	3.75	33100	F 0 9 2 0 1 1 . _ M _ - _ _ 1 1 . 4 A _	256.0	160M	X 6 1 1 0 7 M 0 7 0 - _ _ _	90				
	115	12.68	888	3.52	33100	1 2 .								
	99	14.66	1026	3.30	33100	1 4 .								
	89	16.37	1147	3.09	33100	1 6 .								
	83	17.58	1236	2.92	33100	1 8 .								
	73	20.04	1411	2.70	33100	2 0 .								
	64	22.70	1589	2.55	33100	2 2 .								
	56	25.88	1814	2.33	33100	2 5 .								
	51	28.41	1993	2.16	33051	2 8 .								
	46	31.56	2218	1.94	33002	3 2 .								
	40	36.69	2570	1.64	32953	3 6 .								
	36	40.76	2855	1.48	32983	4 0 .								
	33	44.58	3128	1.38	32925	4 5 .								
	30	49.22	3448	1.25	32955	5 0 .								
25	57.58	4022	1.05	33000	5 6 .									
23	63.56	4448	0.95	32900	6 3 .									
81	18.07	1269	3.87	43500	F 1 0 2 0 1 8 . _ M _ - _ _ 1 1 . 4 A _	342.0	160M	X 6 1 1 0 8 M 0 9 0 - _ _ _	100					
71	20.46	1436	3.59	43500	2 0 .									
64	22.76	1594	3.43	43500	2 2 .									
56	25.77	1804	3.17	43500	2 5 .									
52	28.04	1969	2.96	43417	2 8 .									
47	31.16	2185	2.76	43424	3 2 .									
41	35.32	2476	2.61	43398	3 6 .									
37	39.25	2746	2.44	43398	4 0 .									
33	44.43	3118	2.05	43373	4 5 .									
28	51.19	3597	1.78	43366	5 0 .									
26	55.97	3915	1.85	43322	5 6 .									
23	64.49	4515	1.61	43322	6 3 .									
21	69.24	4831	1.28	43284	7 1 .									
20	74.39	5211	1.08	43293	8 0 .									
17	87.21	6066	1.20	43225	9 0 .									
16	93.70	6540	1.08	43225	1 0 0									
14	102.80	7118	0.89	43200	F 1 0 3 0 1 0 0 _ M _ - _ _ 1 1 . 4 A _	342.0	160M	X 6 1 1 0 9 M 0 9 0 - _ _ _	120					
13	114.24	7909	0.81	43100	1 1 2									
11	129.50	8929	0.81	43100	1 2 5									
								X 6 1 1 1 0 M 0 9 0 - _ _ _	140					

NOTE
Other output speeds are available using 2 and 8 pole motors - Consult Textron Power Transmission

SERIES F

SELECTION TABLES

GEARED MOTORS

9608

	N2 R/MIN	i	M2 Nm	Fm	N	UNIT DESIGNATION	Kg	Motor Frame Size	SERIES X	MM				
	Output Speed	Ratio	Output Torque	Service Factor	Overhung Load	Column Entry 1 Through 20 Spaces to be filled when entering order	Weight of Base Mount Unit		Cone Ring Output Coupling Spaces to be filled when entering order	Max Bore Coupling Driven Half				
11.0 kW	6 POLE													
	190	5.09	536	1.59	12200	F 0 8 2 0 5 . 0 _ M _ - _ _ 1 1 . 6 A _	208.0	160L	X 6 1 1 0 5 M 0 6 0 - _ _ _	70				
	155	6.24	660	1.59	12400	6 . 3			X 6 1 2 0 6 M 0 6 0 - _ _ _	80				
	134	7.21	760	1.59	12500	7 . 1								
	120	8.01	849	1.59	12700	8 . 0			X 6 1 1 0 6 M 0 6 0 - _ _ _	80				
	108	8.91	943	1.59	12900	9 . 0								
	98	9.83	1037	1.59	13200	1 0 .								
	84	11.52	1225	1.45	13100	1 1 .								
	75	12.94	1375	1.35	13100	1 2 .								
	68	14.14	1489	1.42	13500	1 4 .								
	61	15.87	1682	1.33	13400	1 6 .								
	54	17.88	1901	1.08	12900	1 8 .								
	46	20.81	2209	0.98	12600	2 0 .								
	44	21.93	2327	1.08	12900	2 2 .			X 6 1 1 0 7 M 0 6 0 - _ _ _	90				
	38	25.53	2694	0.97	12500	2 5 .								
	147	6.57	694	3.70	33100	F 0 9 2 0 6 . 3 _ M _ - _ _ 1 1 . 6 A _			270.0	160L	X 6 1 1 0 7 M 0 7 0 - _ _ _	90		
	138	7.00	741	3.57	33100	7 . 1								
	123	7.85	831	3.39	33100	8 . 0								
	110	8.81	934	3.20	33100	9 . 0								
	95	10.13	1071	3.01	33100	1 0 .								
	85	11.35	1200	2.81	33084	1 1 .					X 6 1 1 0 8 M 0 7 0 - _ _ _	100		
	76	12.68	1344	2.64	33100	1 2 .								
	66	14.66	1550	2.48	33075	1 4 .								
	59	16.37	1734	2.31	33075	1 6 .								
	55	17.58	1864	2.19	33075	1 8 .								
	48	20.04	2124	2.03	33068	2 0 .								
	43	22.70	2405	1.75	33068	2 2 .								
	37	25.88	2732	1.54	33053	2 5 .								
	34	28.41	3004	1.43	33027	2 8 .								
	31	31.56	3344	1.29	33000	3 2 .								
	26	36.69	3880	1.09	33000	3 6 .								
	24	40.76	4315	0.98	32900	4 0 .								
	84	11.48	1219	3.76	43500	F 1 0 2 0 1 1 . _ M _ - _ _ 1 1 . 6 A _					356.0	160L	X 6 1 1 0 8 M 0 9 0 - _ _ _	100
	78	12.39	1314	3.59	43500	1 2 .								
	67	14.46	1529	3.35	43500	1 4 .							X 6 1 1 0 9 M 0 9 0 - _ _ _	120
	62	15.61	1653	3.20	43484	1 6 .								
	53	18.07	1919	2.90	43484	1 8 .								
	47	20.46	2169	2.69	43468	2 0 .								
	42	22.76	2410	2.57	43468	2 2 .								
	37	25.77	2727	2.38	43453	2 5 .								
34	28.04	2980	2.15	43366	2 8 .									
31	31.16	3303	1.94	43407	3 2 .									
27	35.32	3724	1.95	43360	3 6 .									
25	39.25	4153	1.75	43314	4 0 .									
22	44.43	4700	1.36	43276	4 5 .									
19	51.19	5429	1.18	43288	5 0 .									
17	55.97	5920	1.22	43218	5 6 .									
15	64.49	6780	1.07	43200	6 3 .									
14	69.24	7299	0.85	43200	7 1 .									

NOTE
Other output speeds are available using 2 and 8 pole motors - Consult Textron Power Transmission

SERIES F

SELECTION TABLES

GEARED MOTORS

9608

	N2 R/MIN	i	M2 Nm	Fm	N	UNIT DESIGNATION	Kg	Motor Frame Size	SERIES X	MM	
	Output Speed	Ratio	Output Torque	Service Factor	Overhung Load	Column Entry 1 Through 20 Spaces to be filled when entering order	Weight of Base Mount Unit		Cone Ring Output Coupling Spaces to be filled when entering order	Max Bore Coupling Driven Half	
15.0 kW	4 POLE										
	283	5.15	487	0.87	8950	F 0 7 2 0 5 . 0 _ M _ - _ _ 1 5 . 4 A _	168.0	160L	X 6 1 1 0 4 M 0 5 0 - _ _ _	60	
	227	6.42	607	0.87	9010	6 . 3					
	205	7.14	677	0.87	8750	7 . 1					
	182	8.02	762	0.87	8610	8 . 0			X 6 1 1 0 5 M 0 5 0 - _ _ _	70	
	166	8.81	838	0.87	8460	9 . 0					
	146	9.99	949	0.87	8630	1 0 .					
	127	11.51	1095	0.87	8260	1 1 .			X 6 1 2 0 6 M 0 5 0 - _ _ _	80	
	112	13.09	1247	0.83	8070	1 2 .			X 6 1 1 0 6 M 0 5 0 - _ _ _	80	
	102	14.35	1365	0.81	8240	1 4 .					
	287	5.09	482	1.77	11200	F 0 8 2 0 5 . 0 _ M _ - _ _ 1 5 . 4 A _	207.0	160L	X 6 1 1 0 5 M 0 6 0 - _ _ _	70	
	234	6.24	589	1.77	11400	6 . 3			X 6 1 2 0 6 M 0 6 0 - _ _ _	80	
	202	7.21	685	1.77	11300	7 . 1					
	182	8.01	764	1.77	11200	8 . 0			X 6 1 1 0 6 M 0 6 0 - _ _ _	80	
	164	8.91	847	1.70	11200	9 . 0					
	149	9.83	935	1.68	11400	1 0 .					
	127	11.52	1100	1.46	11300	1 1 .					
	113	12.94	1232	1.36	11300	1 2 .					
	103	14.14	1345	1.39	11500	1 4 .					
	92	15.87	1512	1.30	11500	1 6 .					
	82	17.88	1701	1.09	11000	1 8 .					
	70	20.81	1989	0.98	10700	2 0 .					
	67	21.93	2081	1.08	11000	2 2 .					
	57	25.53	2438	0.98	10500	2 5 .			X 6 1 1 0 7 M 0 6 0 - _ _ _	90	
	222	6.57	625	3.63	33100	F 0 9 2 0 6 . 3 _ M _ - _ _ 1 5 . 4 A _	269.0	160L	X 6 1 1 0 6 M 0 7 0 - _ _ _	80	
	209	7.00	666	3.51	33100	7 . 1					
	186	7.85	749	3.32	33100	8 . 0			X 6 1 1 0 7 M 0 7 0 - _ _ _	90	
	166	8.81	840	3.14	33100	9 . 0					
	144	10.13	963	2.95	33100	1 0 .					
	129	11.35	1083	2.76	33088	1 1 .					
	115	12.68	1207	2.59	33088	1 2 .					
	100	14.66	1395	2.43	33076	1 4 .			X 6 1 1 0 8 M 0 7 0 - _ _ _	100	
	89	16.37	1560	2.28	33084	1 6 .					
	83	17.58	1680	2.15	33084	1 8 .					
	73	20.04	1917	1.99	33069	2 0 .					
	64	22.70	2160	1.88	33057	2 2 .					
	56	25.88	2465	1.71	33057	2 5 .					
	51	28.41	2709	1.59	33032	2 8 .					
	46	31.56	3014	1.43	32965	3 2 .					
	40	36.69	3492	1.21	32897	3 6 .					
	36	40.76	3880	1.09	32938	4 0 .					
	33	44.58	4252	1.01	32858	4 5 .					
	30	49.22	4686	0.92	32900	5 0 .					
	127	11.48	1094	3.69	43500	F 1 0 2 0 1 1 . _ M _ - _ _ 1 5 . 4 A _	355.0	160L	X 6 1 1 0 8 M 0 9 0 - _ _ _	100	
	118	12.39	1183	3.52	43500	1 2 .					
101	14.46	1377	3.29	43500	1 4 .						
94	15.61	1486	3.14	43488	1 6 .						
81	18.07	1725	2.85	43488	1 8 .						
71	20.46	1952	2.64	43476	2 0 .			X 6 1 1 0 9 M 0 9 0 - _ _ _	120		
64	22.76	2167	2.52	43476	2 2 .						
57	25.77	2452	2.34	43464	2 5 .						
52	28.04	2675	2.17	43380	2 8 .						
47	31.16	2969	2.03	43389	3 2 .						
41	35.32	3364	1.92	43352	3 6 .						
37	39.25	3732	1.79	43352	4 0 .						
33	44.43	4237	1.51	43315	4 5 .						
29	51.19	4889	1.31	43306	5 0 .						
26	55.97	5320	1.36	43241	5 6 .						
23	64.49	6136	1.18	43241	6 3 .						
21	69.24	6565	0.94	43185	7 1 .						
17	87.21	8244	0.88	43100	9 0 .						

NOTE
Other output speeds are available using 2 and 8 pole motors - Consult Textron Power Transmission

SERIES F

SELECTION TABLES

GEARED MOTORS

9608

	N2 R/MIN	i	M2 Nm	Fm	N	UNIT DESIGNATION	Kg	SERIES X	MM			
	Output Speed	Ratio	Output Torque	Service Factor	Overhung Load	Column Entry <input type="text" value="1"/> Through <input type="text" value="20"/> Spaces to be filled when entering order	Weight of Base Mount Unit	Cone Ring Output Coupling Spaces to be filled when entering order	Max Bore Coupling Driven Half			
							Motor Frame Size					
6 POLE	191	5.08	730	3.04	33100	F 0 9 2 0 5 . 0 _ M _ - _ _ 1 5 . 6 A _	294.0	180L	80			
	148	6.57	942	2.73	33100	6 . 3						
	139	7.00	1006	2.63	33100	7 . 1						
	124	7.85	1128	2.50	33100	8 . 0						
	110	8.81	1268	2.36	33100	9 . 0						
	96	10.13	1452	2.22	33100	1 0 .						
	85	11.35	1629	2.07	33066	1 1 .						
	77	12.68	1823	1.95	33100	1 2 .						
	66	14.66	2103	1.83	33048	1 4 .						
	59	16.37	2352	1.70	33048	1 6 .						
	55	17.58	2529	1.62	33048	1 8 .						
	48	20.04	2882	1.50	33031	2 0 .						
	43	22.70	3262	1.29	33031	2 2 .						
	37	25.88	3706	1.14	33000	2 5 .						
	34	28.41	4075	1.06	33000	2 8 .						
	190	5.11	733	3.49	43500	F 1 0 2 0 5 . 0 _ M _ - _ _ 1 5 . 6 A _				380.0	180L	90
	151	6.43	922	3.49	43500	6 . 3						
	136	7.13	1025	3.49	43500	7 . 1						
	125	7.76	1115	3.39	43500	8 . 0						
	110	8.81	1270	3.18	43500	9 . 0						
99	9.77	1402	3.04	43500	1 0 .							
85	11.48	1654	2.77	43500	1 1 .							
78	12.39	1782	2.65	43500	1 2 .							
67	14.46	2075	2.47	43500	1 4 .							
62	15.61	2243	2.36	43466	1 6 .							
54	18.07	2603	2.14	43466	1 8 .							
47	20.46	2943	1.98	43433	2 0 .							
43	22.76	3270	1.89	43433	2 2 .							
38	25.77	3699	1.75	43400	2 5 .							
35	28.04	4042	1.58	43310	2 8 .							
31	31.16	4481	1.43	43368	3 2 .							
27	35.32	5052	1.43	43302	3 6 .							
25	39.25	5635	1.29	43236	4 0 .							
22	44.43	6376	1.00	43182	4 5 .							
19	51.19	7365	0.87	43200	5 0 .							
17	55.97	8032	0.90	43100	5 6 .							

NOTE
Other output speeds are available using 2 and 8 pole motors - Consult Textron Power Transmission

SERIES F

SELECTION TABLES

GEARED MOTORS

9608

	18.0 kW	N2 R/MIN	i	M2 Nm	Fm	N	UNIT DESIGNATION	Kg	SERIES X	MM	
		Output Speed	Ratio	Output Torque	Service Factor	Overhung Load	Column Entry <input type="text" value="1"/> Through <input type="text" value="20"/> Spaces to be filled when entering order	Weight of Base Mount Unit	Cone Ring Output Coupling Spaces to be filled when entering order	Max Bore Coupling Driven Half	
								Motor Frame Size			
4 POLE		287	5.08	597	3.28	33100	F 0 9 2 0 5 . 0 _ M _ _ _ 1 8 . 4 A _	292.0		80	
		222	6.57	770	2.94	33100	6 . 3				
		209	7.00	822	2.85	33100	7 . 1				
		186	7.85	924	2.69	33100	8 . 0		X 6 1 1 0 7 M 0 7 0 - _ _ _	90	
		166	8.81	1036	2.55	33100	9 . 0				
		144	10.13	1188	2.39	33100	1 0 .				
		129	11.35	1336	2.24	33077	1 1 .				
		115	12.68	1489	2.10	33077	1 2 .				
		100	14.66	1720	1.97	33055	1 4 .		X 6 1 1 0 8 M 0 7 0 - _ _ _	100	
		89	16.37	1924	1.85	33071	1 6 .				
		83	17.58	2072	1.74	33071	1 8 .				
		73	20.04	2364	1.61	33042	2 0 .				
		64	22.70	2664	1.52	33021	2 2 .				
		56	25.88	3040	1.39	33021	2 5 .				
		51	28.41	3341	1.29	33016	2 8 .				
		46	31.56	3717	1.16	32932	3 2 .				
		40	36.69	4307	0.98	32848	3 6 .				
		36	40.76	4786	0.88	32900	4 0 .				
		33	44.58	5244	0.82	32800	4 5 .		X 6 1 1 0 9 M 0 7 0 - _ _ _	120	
		205	7.13	839	3.81	43500	F 1 0 2 0 7 . 1 _ M _ _ _ 1 8 . 4 A _	378.0	180M	X 6 1 1 0 7 M 0 9 0 - _ _ _	90
		188	7.76	913	3.66	43500	8 . 0				
		166	8.81	1036	3.43	43500	9 . 0		X 6 1 1 0 8 M 0 9 0 - _ _ _	100	
		149	9.77	1146	3.29	43500	1 0 .				
	127	11.48	1349	2.99	43500	1 1 .					
	118	12.39	1459	2.86	43500	1 2 .					
	101	14.46	1698	2.67	43500	1 4 .					
	94	15.61	1833	2.55	43477	1 6 .					
	81	18.07	2127	2.31	43477	1 8 .					
	71	20.46	2407	2.14	43455	2 0 .		X 6 1 1 0 9 M 0 9 0 - _ _ _	120		
	64	22.76	2672	2.05	43455	2 2 .					
	57	25.77	3025	1.89	43433	2 5 .					
	52	28.04	3300	1.76	43347	2 8 .					
	47	31.16	3662	1.65	43359	3 2 .					
	41	35.32	4150	1.56	43312	3 6 .					
	37	39.25	4603	1.45	43312	4 0 .					
	33	44.43	5226	1.22	43265	4 5 .					
	29	51.19	6030	1.06	43253	5 0 .					
	26	55.97	6561	1.10	43170	5 6 .					
	23	64.49	7568	0.96	43170	6 3 .					
6 POLE		191	5.08	901	2.46	33100	F 0 9 2 0 5 . 0 _ M _ _ _ 1 8 . 6 A _	309.0	200LA	X 6 1 1 0 6 M 0 7 0 - _ _ _	80
		148	6.57	1161	2.21	33100	6 . 3		X 6 1 1 0 7 M 0 7 0 - _ _ _	90	
		139	7.00	1240	2.14	33100	7 . 1				
		124	7.85	1391	2.03	33100	8 . 0				
		110	8.81	1564	1.91	33100	9 . 0				
		96	10.13	1791	1.80	33100	1 0 .				
		85	11.35	2009	1.68	33051	1 1 .		X 6 1 1 0 8 M 0 7 0 - _ _ _	100	
		77	12.68	2249	1.58	33100	1 2 .				
		66	14.66	2594	1.48	33024	1 4 .				
		59	16.37	2901	1.38	33024	1 6 .				
		55	17.58	3120	1.31	33024	1 8 .				
		48	20.04	3554	1.21	33000	2 0 .				
		43	22.70	4024	1.05	33000	2 2 .				
		190	5.11	904	2.83	43500	F 1 0 2 0 5 . 0 _ M _ _ _ 1 8 . 6 A _	395.0	200LA	X 6 1 1 0 7 M 0 9 0 - _ _ _	90
		151	6.43	1138	2.83	43500	6 . 3				
		136	7.13	1265	2.83	43500	7 . 1		X 6 1 1 0 8 M 0 9 0 - _ _ _	100	
		125	7.76	1375	2.75	43500	8 . 0				
		110	8.81	1567	2.58	43500	9 . 0				
		99	9.77	1729	2.47	43500	1 0 .				
		85	11.48	2040	2.24	43500	1 1 .				
		78	12.39	2198	2.15	43500	1 2 .				
		67	14.46	2559	2.00	43500	1 4 .		X 6 1 1 0 9 M 0 9 0 - _ _ _	120	
		62	15.61	2767	1.91	43451	1 6 .				
	54	18.07	3211	1.73	43451	1 8 .					
	47	20.46	3630	1.61	43402	2 0 .					
	43	22.76	4033	1.53	43402	2 2 .					
	38	25.77	4563	1.42	43353	2 5 .					
	35	28.04	4986	1.28	43261	2 8 .					
	31	31.16	5527	1.16	43334	3 2 .					
	27	35.32	6232	1.16	43251	3 6 .					
	25	39.25	6949	1.04	43168	4 0 .					
	22	44.43	7864	0.81	43100	4 5 .					

NOTE
Other output speeds are available using 2 and 8 pole motors - Consult Textron Power Transmission

SERIES F

SELECTION TABLES

GEARED MOTORS

9608

	N2 R/MIN	i	M2 Nm	Fm	N	UNIT DESIGNATION	Kg	Motor Frame Size	SERIES X	MM	
	Output Speed	Ratio	Output Torque	Service Factor	Overhung Load	Column Entry 1 Through 20 Spaces to be filled when entering order	Weight of Base Mount Unit		Cone Ring Output Coupling Spaces to be filled when entering order	Max Bore Coupling Driven Half	
22.0 kW	4 POLE										
	288	5.08	707	2.77	33100	F 0 9 2 0 5 . 0 _ M _ - _ _ 2 2 . 4 A _	328.0	180L	X 6 1 1 0 6 M 0 7 0 - _ _ _	80	
	223	6.57	913	2.48	33100	6 . 3					
	209	7.00	974	2.40	33100	7 . 1					
	187	7.85	1095	2.27	33100	8 . 0			X 6 1 1 0 7 M 0 7 0 - _ _ _	90	
	166	8.81	1228	2.15	33100	9 . 0					
	145	10.13	1408	2.02	33100	1 0 .					
	129	11.35	1584	1.89	33067	1 1 .					
	116	12.68	1765	1.77	33067	1 2 .					
	100	14.66	2039	1.66	33035	1 4 .			X 6 1 1 0 8 M 0 7 0 - _ _ _	100	
	89	16.37	2280	1.56	33057	1 6 .					
	83	17.58	2456	1.47	33057	1 8 .					
	73	20.04	2802	1.36	33015	2 0 .					
	65	22.70	3157	1.29	32984	2 2 .					
	57	25.88	3603	1.17	32984	2 5 .					
	52	28.41	3959	1.09	33000	2 8 .					
	46	31.56	4406	0.98	32900	3 2 .					
	40	36.69	5104	0.83	32800	3 6 .			X 6 1 1 0 9 M 0 7 0 - _ _ _	120	
	287	5.11	712	3.59	43500	F 1 0 2 0 5 . 0 _ M _ - _ _ 2 2 . 4 A _	414.0	180L	X 6 1 1 0 7 M 0 9 0 - _ _ _	90	
	228	6.43	893	3.38	43500	6 . 3					
	205	7.13	995	3.21	43500	7 . 1					
	189	7.76	1082	3.09	43500	8 . 0					
	166	8.81	1228	2.90	43500	9 . 0			X 6 1 1 0 8 M 0 9 0 - _ _ _	100	
150	9.77	1359	2.77	43500	1 0 .						
128	11.48	1599	2.53	43500	1 1 .						
118	12.39	1729	2.41	43500	1 2 .						
101	14.46	2013	2.25	43500	1 4 .						
94	15.61	2172	2.15	43467	1 6 .						
81	18.07	2521	1.95	43467	1 8 .						
72	20.46	2853	1.80	43435	2 0 .			X 6 1 1 0 9 M 0 9 0 - _ _ _	120		
64	22.76	3167	1.73	43435	2 2 .						
57	25.77	3585	1.60	43402	2 5 .						
52	28.04	3911	1.49	43314	2 8 .						
47	31.16	4340	1.39	43329	3 2 .						
41	35.32	4918	1.31	43272	3 6 .						
37	39.25	5455	1.23	43272	4 0 .						
33	44.43	6193	1.03	43215	4 5 .						
29	51.19	7146	0.90	43200	5 0 .						
26	55.97	7776	0.93	43100	5 6 .						
23	64.49	8969	0.81	43100	6 3 .			X 6 1 1 1 0 M 0 9 0 - _ _ _	140		
22.0 kW	6 POLE										
	191	5.08	1071	2.07	33100	F 0 9 2 0 5 . 0 _ M _ - _ _ 2 2 . 6 A _	329.0	200LB	X 6 1 1 0 6 M 0 7 0 - _ _ _	80	
	148	6.57	1381	1.86	33100	6 . 3			X 6 1 1 0 7 M 0 7 0 - _ _ _	90	
	139	7.00	1475	1.80	33100	7 . 1					
	124	7.85	1654	1.70	33100	8 . 0					
	110	8.81	1860	1.61	33100	9 . 0					
	96	10.13	2130	1.51	33100	1 0 .					
	85	11.35	2389	1.41	33035	1 1 .			X 6 1 1 0 8 M 0 7 0 - _ _ _	100	
	77	12.68	2674	1.33	33100	1 2 .					
	66	14.66	3085	1.24	33000	1 4 .					
	59	16.37	3451	1.16	33000	1 6 .					
	55	17.58	3710	1.10	33000	1 8 .					
	190	5.11	1076	2.38	43500	F 1 0 2 0 5 . 0 _ M _ - _ _ 2 2 . 6 A _	415.0	200LB	X 6 1 1 0 7 M 0 9 0 - _ _ _	90	
	151	6.43	1353	2.38	43500	6 . 3					
	136	7.13	1504	2.38	43500	7 . 1					
	125	7.76	1636	2.31	43500	8 . 0			X 6 1 1 0 8 M 0 9 0 - _ _ _	100	
	110	8.81	1863	2.17	43500	9 . 0					
	99	9.77	2056	2.08	43500	1 0 .					
	85	11.48	2426	1.89	43500	1 1 .					
	78	12.39	2614	1.80	43500	1 2 .					
	67	14.46	3043	1.69	43500	1 4 .					
	62	15.61	3290	1.61	43435	1 6 .					
	54	18.07	3818	1.46	43435	1 8 .					
47	20.46	4317	1.35	43371	2 0 .						
43	22.76	4796	1.29	43371	2 2 .			X 6 1 1 0 9 M 0 9 0 - _ _ _	120		
38	25.77	5426	1.19	43306	2 5 .						
35	28.04	5929	1.08	43212	2 8 .						
31	31.16	6573	0.97	43300	3 2 .						
27	35.32	7411	0.98	43200	3 6 .						
25	39.25	8264	0.88	43100	4 0 .						

NOTE
Other output speeds are available using 2 and 8 pole motors - Consult Textron Power Transmission

SERIES F

SELECTION TABLES

GEARED MOTORS

9608

30.0 kW	N2 R/MIN	i	M2 Nm	Fm	N	UNIT DESIGNATION	Kg	SERIES X	MM	
4 POLE	Output Speed	Ratio	Output Torque	Service Factor	Overhung Load	Column Entry 1 Through 20 Spaces to be filled when entering order	Weight of Base Mount Unit	Motor Frame Size	Cone Ring Output Coupling Spaces to be filled when entering order	Max Bore Coupling Driven Half
	289	5.08	961	2.04	33100	F 0 9 2 0 5 . 0 _ M _ _ _ 30 . 4 A _	352.0	200L	X 6 1 1 0 6 M 0 7 0 - _ _ _	80
	224	6.57	1241	1.83	33100	6 . 3				
	210	7.00	1323	1.77	33100	7 . 1				
	187	7.85	1488	1.67	33100	8 . 0			X 6 1 1 0 7 M 0 7 0 - _ _ _	90
	167	8.81	1669	1.58	33100	9 . 0				
	145	10.13	1914	1.48	33100	1 0 .				
	130	11.35	2152	1.39	33044	1 1 .				
	116	12.68	2399	1.30	33044	1 2 .				
	100	14.66	2771	1.22	32988	1 4 .			X 6 1 1 0 8 M 0 7 0 - _ _ _	100
	90	16.37	3098	1.15	33026	1 6 .				
	84	17.58	3338	1.08	33026	1 8 .				
	73	20.04	3808	1.00	32953	2 0 .				
	65	22.70	4290	0.95	32900	2 2 .				
	57	25.88	4897	0.86	32900	2 5 .				
	288	5.11	968	2.64	43500	F 1 0 2 0 5 . 0 _ M _ _ _ 30 . 4 A _	438.0	200L	X 6 1 1 0 7 M 0 9 0 - _ _ _	90
	229	6.43	1214	2.49	43500	6 . 3				
	206	7.13	1352	2.37	43500	7 . 1				
	189	7.76	1470	2.27	43500	8 . 0				
	167	8.81	1669	2.13	43500	9 . 0			X 6 1 1 0 8 M 0 9 0 - _ _ _	100
	150	9.77	1847	2.04	43500	1 0 .				
	128	11.48	2173	1.86	43500	1 1 .				
	119	12.39	2350	1.77	43500	1 2 .				
	102	14.46	2735	1.66	43500	1 4 .				
	94	15.61	2952	1.58	43444	1 6 .				
	81	18.07	3426	1.43	43444	1 8 .				
	72	20.46	3877	1.33	43388	2 0 .			X 6 1 1 0 9 M 0 9 0 - _ _ _	120
	65	22.76	4304	1.27	43388	2 2 .				
	57	25.77	4872	1.18	43332	2 5 .				
	52	28.04	5315	1.09	43240	2 8 .				
	47	31.16	5898	1.02	43260	3 2 .				
	42	35.32	6684	0.97	43180	3 6 .				
	37	39.25	7414	0.90	43180	4 0 .				
	192	5.08	1453	1.53	33100	F 0 9 2 0 5 . 0 _ M _ _ _ 30 . 6 A _	414.0	225M	X 6 1 1 0 6 M 0 7 0 - _ _ _ X 6 1 1 0 7 M 0 7 0 - _ _ _	80 90
	148	6.57	1874	1.37	33100	6 . 3				
	139	7.00	2001	1.32	33100	7 . 1				
	124	7.85	2245	1.26	33100	8 . 0				
	111	8.81	2523	1.18	33100	9 . 0				
	96	10.13	2890	1.11	33100	1 0 .				
	86	11.35	3241	1.04	33000	1 1 .			X 6 1 1 0 8 M 0 7 0 - _ _ _	100
	191	5.11	1459	1.75	43500	F 1 0 2 0 5 . 0 _ M _ _ _ 30 . 6 A _	500.0	225M	X 6 1 1 0 7 M 0 9 0 - _ _ _	90
	152	6.43	1836	1.75	43500	6 . 3				
	137	7.13	2041	1.75	43500	7 . 1			X 6 1 1 0 8 M 0 9 0 - _ _ _	100
	126	7.76	2219	1.70	43500	8 . 0				
	111	8.81	2528	1.60	43500	9 . 0				
	100	9.77	2790	1.53	43500	1 0 .				
	85	11.48	3291	1.39	43500	1 1 .				
	79	12.39	3547	1.33	43500	1 2 .				
	67	14.46	4128	1.24	43500	1 4 .			X 6 1 1 0 9 M 0 9 0 - _ _ _	120
	62	15.61	4464	1.18	43400	1 6 .				
	54	18.07	5180	1.07	43400	1 8 .				
	48	20.46	5857	1.00	43300	2 0 .				
	43	22.76	6506	0.95	43300	2 2 .				
	38	25.77	7361	0.88	43200	2 5 .				

NOTE
Other output speeds are available using 2 and 8 pole motors - Consult Textron Power Transmission

SERIES F

SELECTION TABLES

GEARED MOTORS

9608

37.0 kW		N2 R/MIN	i	M2 Nm	Fm	N	UNIT DESIGNATION	Kg		SERIES X	MM	
4 POLE	Output Speed	Ratio	Output Torque	Service Factor	Overhung Load	Column Entry <input type="text" value="1"/> Through <input type="text" value="20"/> Spaces to be filled when entering order	Weight of Base Mount Unit	Motor Frame Size	Cone Ring Output Coupling Spaces to be filled when entering order	Max Bore Coupling Driven Half		
		290	5.08	1182	1.66	33100	F 0 9 2 0 5 . 0 _ M _ - _ _ 3 7 . 4 A _	405.0	225S	X 6 1 1 0 6 M 0 7 0 - _ _ _	80	
	225	6.57	1526	1.49	33100	6 . 3						
	211	7.00	1627	1.44	33100	7 . 1						
	188	7.85	1829	1.36	33100	8 . 0						
	167	8.81	2051	1.29	33100	9 . 0						
	146	10.13	2353	1.21	33100	1 0 .						
	130	11.35	2646	1.13	33023	1 1 .						
	116	12.68	2949	1.06	33023	1 2 .						
	101	14.66	3406	1.00	32947	1 4 .						
	90	16.37	3808	0.93	33000	1 6 .						
	84	17.58	4103	0.88	33000	1 8 .						
	74	20.04	4681	0.81	32900	2 0 .						
	289	5.11	1190	2.15	43500	F 1 0 2 0 5 . 0 _ M _ - _ _ 3 7 . 4 A _	491.0			225S	X 6 1 1 0 7 M 0 9 0 - _ _ _	90
	229	6.43	1492	2.02	43500	6 . 3						
	207	7.13	1662	1.92	43500	7 . 1						
	190	7.76	1807	1.85	43500	8 . 0						
	167	8.81	2052	1.73	43500	9 . 0						
	151	9.77	2270	1.66	43500	1 0 .						
	129	11.48	2671	1.51	43500	1 1 .						
	119	12.39	2889	1.44	43500	1 2 .						
	102	14.46	3362	1.35	43500	1 4 .						
	94	15.61	3629	1.29	43423	1 6 .						
	82	18.07	4212	1.17	43423	1 8 .						
	72	20.46	4766	1.08	43347	2 0 .						
	65	22.76	5291	1.03	43347	2 2 .						
	57	25.77	5988	0.96	43270	2 5 .						
	53	28.04	6533	0.89	43174	2 8 .						
	47	31.16	7250	0.83	43200	3 2 .						

45.0 kW

45.0 kW		N2 R/MIN	i	M2 Nm	Fm	N	UNIT DESIGNATION	Kg		SERIES X	MM	
4 POLE	Output Speed	Ratio	Output Torque	Service Factor	Overhung Load	Column Entry <input type="text" value="1"/> Through <input type="text" value="20"/> Spaces to be filled when entering order	Weight of Base Mount Unit	Motor Frame Size	Cone Ring Output Coupling Spaces to be filled when entering order	Max Bore Coupling Driven Half		
		290	5.08	1437	1.36	33100	F 0 9 2 0 5 . 0 _ M _ - _ _ 4 5 . 4 A _	423.0	225M	X 6 1 1 0 6 M 0 7 0 - _ _ _	80	
	225	6.57	1856	1.22	33100	6 . 3						
	211	7.00	1979	1.18	33100	7 . 1						
	188	7.85	2225	1.12	33100	8 . 0						
	167	8.81	2495	1.06	33100	9 . 0						
	146	10.13	2861	0.99	33100	1 0 .						
	130	11.35	3218	0.93	33000	1 1 .						
	116	12.68	3587	0.87	33000	1 2 .						
	101	14.66	4142	0.82	32900	1 4 .						
	289	5.11	1448	1.77	43500	F 1 0 2 0 5 . 0 _ M _ - _ _ 4 5 . 4 A _	509.0			225M	X 6 1 1 0 7 M 0 9 0 - _ _ _	90
	229	6.43	1815	1.66	43500	6 . 3						
	207	7.13	2022	1.58	43500	7 . 1						
	190	7.76	2198	1.52	43500	8 . 0						
	167	8.81	2495	1.43	43500	9 . 0						
	151	9.77	2761	1.37	43500	1 0 .						
	129	11.48	3249	1.24	43500	1 1 .						
	119	12.39	3513	1.19	43500	1 2 .						
	102	14.46	4089	1.11	43500	1 4 .						
	94	15.61	4414	1.06	43400	1 6 .						
	82	18.07	5122	0.96	43400	1 8 .						
	72	20.46	5796	0.89	43300	2 0 .						
	65	22.76	6435	0.85	43300	2 2 .						

<p>NOTE</p> <p>Other output speeds are available using 2 and 8 pole motors - Consult Textron Power Transmission</p>
--

SERIES F

DIMENSIONS

DOUBLE REDUCTION

9706

F		2	0			W	M
---	--	---	---	--	--	---	---

STANDARD UNIT

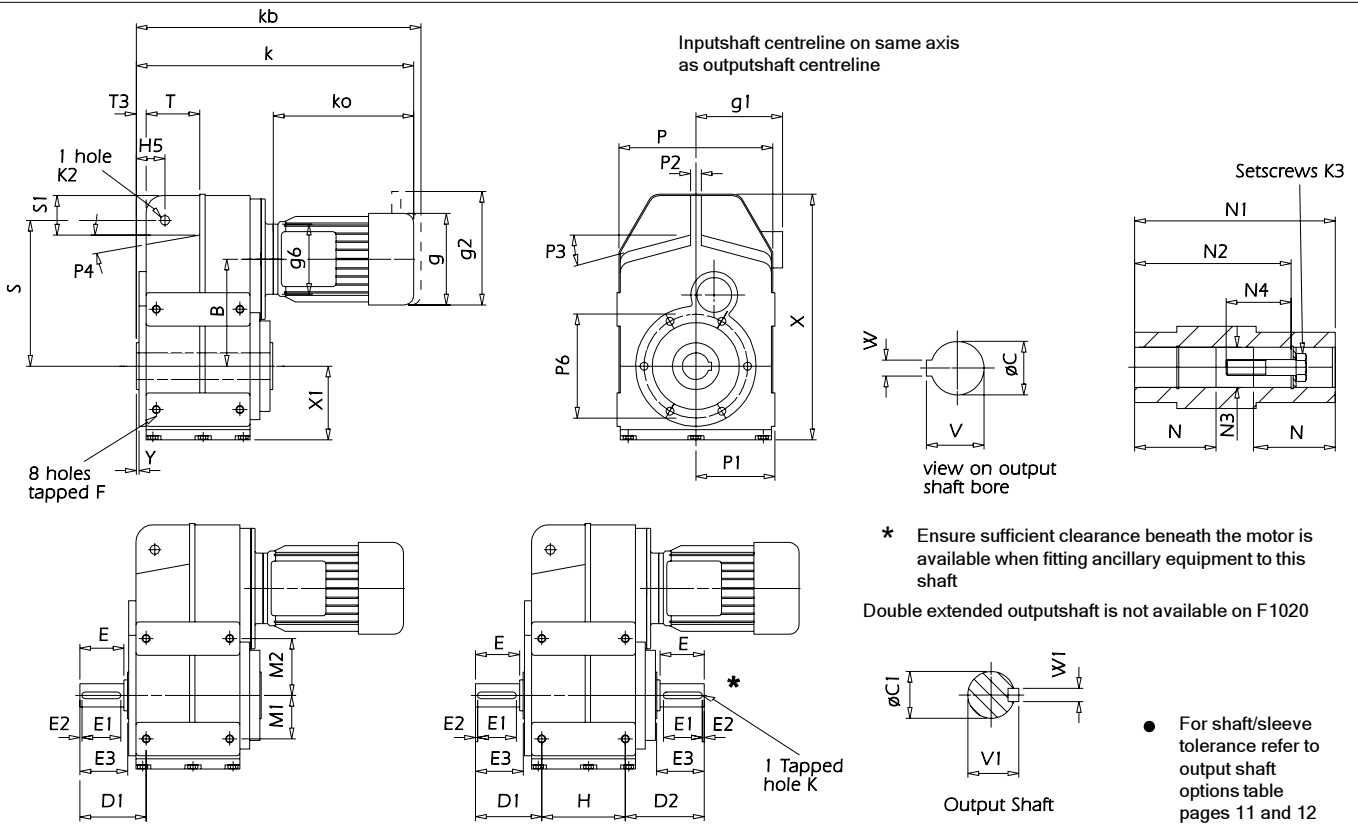

SIZE	B	øC	øC1	D1	D2	E	E1	E2	E3	F	H	H5	K	øK2	K3	M1	M2	N
F0420	120	30	30	85	97	57	50	3	61	M10x1.5x17	90	32	M10x1.5x22	14	M10x50L	50	60	67.5
F0620	160	40	35	99	118	66	58	3	71	M12x1.75x20	125	41	M16x2x36	14	M16x70L	65	85	90
F0720	200	50	50	121	146	86	80	3	91	M16x2x25	150	50	M16x2x36	22	M16x70L	85	115	105
F0820	226	60	60	155	180	114	100	3	120	M16x2x24	170	62	M20x2.5x42	22	M20x80L	100	100	117.5
F0920	274	70	70	179	218	135	110	3	141	M16 x 2Px24	215	70	M20 x 2.5x42	27	M20x80L	125	225	147.5
F1020	332	80	90	213.5	-	172	140	5	172	M20 x 2Px27	250	88	M20 x 2.5x42	27	M20x80L	158	272	165

SIZE	N1	N2	øN3	N4	P	P1	P2	P3	P4	P6	S	S1	T	T3	V	V1	W	W1	X	X1	Y
F0420	150	122	30.2	42	166	88	12	11°	10°	4 holes, M8x1.25 x14, 130 pcd	170	50	55	13	33.5	33	8	8	282	85	3
F0620	200	156	40.2	60	226	118	16	15°	10°	6 holes, M12x1.75 x20, 150 pcd	218	59	80	13	43.5	38	12	10	367	110	2
F0720	235	183	50.2	60	266	140	20	20°	11°	6 holes, M12x1.75 x20, 150 pcd	278	68	95	13	54	53.5	14	14	449	134	2
F0820	265	210	60.2	66	320	170	26	20°	11°	8 holes, M12x1.75 x20, 195 pcd	346	79	105	15	64.5	64	18	18	526	148	3
F0920	330	270	70.2	66	384	200	30	20°	11°	6 holes, M16x2P x27, 230 pcd	395	100	131	19	75	74.5	20	20	612	175	5
F1020	370	313	80.2	66	454	235	36	17°	10°	10 holes, M16x2P x27, 280 pcd	485	136	152	19.5	85	95	22	25	748	216	5.5

MOTORS		ALL SIZES						F0420		F0620		F0720		F0820		F0920		F1020	
		ko	g	g1	g2	g6	k	kb	k	kb	k	kb	k	kb	k	kb	k	kb	
MOTOR FRAME SIZE	63	185	122	101	160	140	322	364	382	424	-	-	-	-	-	-	-	-	
	71	210	137	107	167	105	351	392	413	454	-	-	-	-	-	-	-	-	
	80	230	158	118	190	120	386	436	433	483	474	524	525	575	584	634	-	-	
	90S/L	270	177	149	218	140	436	495	482	541	524	583	565	624	624	683	-	-	
	100/112	340	197	159	238	160	514	582	596	664	617	685	641	709	700	768	729.5	797.5	
	132	402	253	184	288	200	-	-	660	731	681	752	703	774	762	833	791.5	862.5	
	160M/L	538	314	230	*	350	-	-	-	-	847	*	869	*	933	*	962.5	*	
	180L	613	354	257	*	350	-	-	-	-	-	-	-	-	1008	*	1037.5	*	
	200L	613	354	257	*	400	-	-	-	-	-	-	-	-	1008	*	1037.5	*	
225S/M	690	411	280	*	450	-	-	-	-	-	-	-	-	1112	*	1141.5	*		

* Consult Textron Power Transmission

SERIES F

DIMENSIONS

TRIPLE REDUCTION SIZES F04, F06 & F07

9610

F	0	3	0			W	M
---	---	---	---	--	--	---	---

STANDARD UNIT TRIPLE REDUCTION

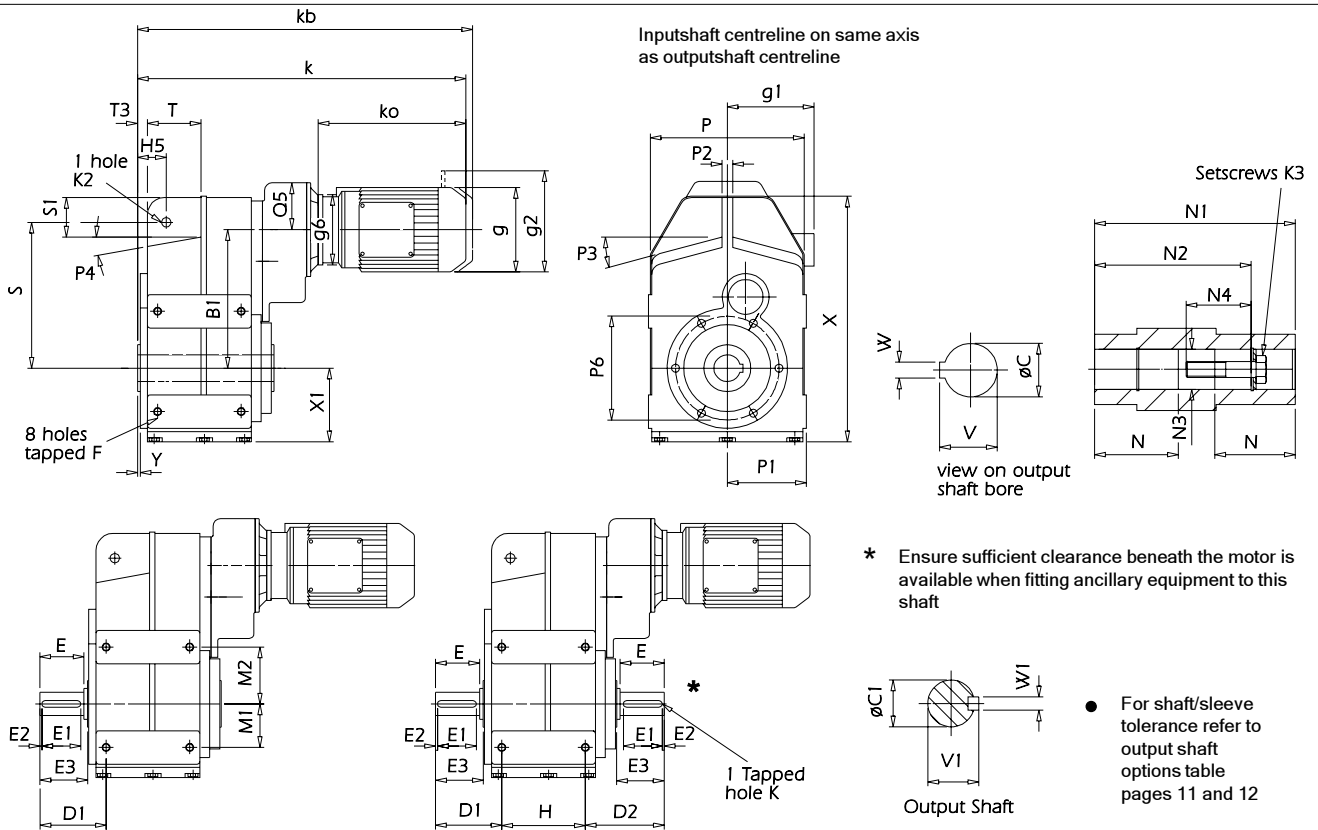

SIZE	B1	øC	øC1	D1	D2	E	E1	E2	E3	F	H	H5	K	øK2	K3	M1	M2	N
F0430	156	30	30	85	97	57	50	3	61	M10x1.5x17	90	32	M10x1.5x22	14	M10x50L	50	60	67.5
F0630	207	40	35	99	118	66	58	3	71	M12x1.75x20	125	41	M16x2x36	14	M16x70L	65	85	90
F0730	260	50	50	121	146	86	80	3	91	M16x2x25	150	50	M16x2x36	22	M16x70L	85	115	105

SIZE	N1	N2	øN3	N4	P	P1	P2	P3	P4	P6	Q5	S	S1	T	T3	V	V1	W	W1	X	X1	Y
F0430	150	122	30.2	42	166	88	12	11°	10°	4 holes, M8x1.25x14, 130 pcd	70	170	50	55	13	33.5	33	8	8	282	85	3
F0630	200	156	40.2	60	226	118	16	15°	10°	6 holes, M12x1.75x20, 150 pcd	70	218	59	80	13	43.5	38	12	10	367	110	2
F0730	235	183	50.2	60	266	140	20	20°	11°	6 holes, M12x1.75x20, 150 pcd	90	278	68	95	13	54	53.5	14	14	449	134	2

MOTORS		ALL SIZES						F0430		F0630		F0730	
		ko	g	g1	g2	g6	k	kb	k	kb	k	kb	
MOTOR FRAME SIZE	63	185	122	101	160	140	378	420	449	491	503	545	
	71	210	137	107	167	105	407	448	478	519	534	575	
	80	230	158	118	190	120	442	492	513	563	554	604	
	90S/L	270	177	149	218	140	-	-	563	622	603	662	
	100/112	340	197	159	238	160	-	-	641	709	717	785	
	132	402	253	184	288	200	-	-	-	-	781	852	

SERIES F

DIMENSIONS

TRIPLE REDUCTION SIZES F08, F09 & F10

9706

F			3	0					W	M
---	--	--	---	---	--	--	--	--	---	---

STANDARD UNIT

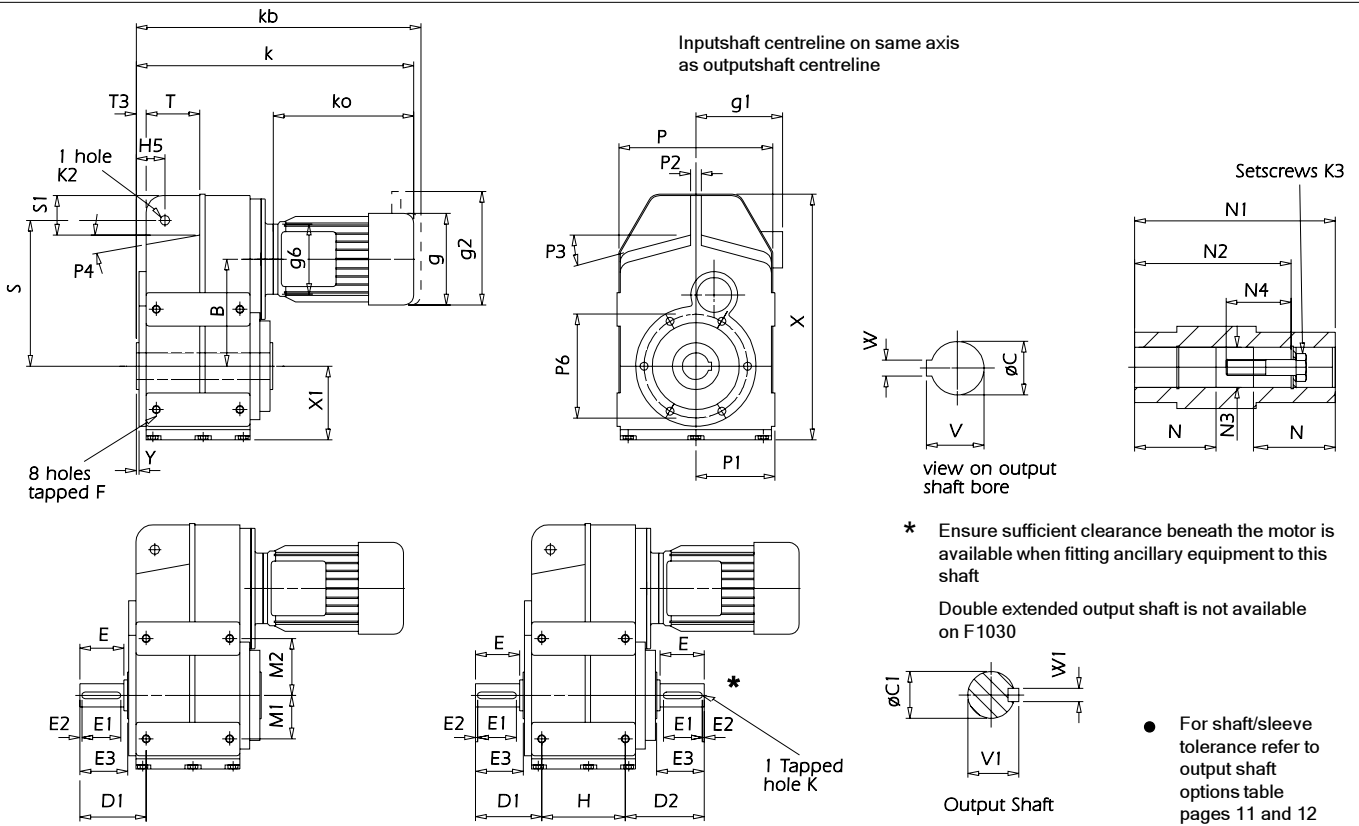

SIZE	B	øC	øC1	D1	D2	E	E1	E2	E3	F	H	H5	K	øK2	K3	M1	M2
F0830	226	60	60	155	180	114	100	3	120	M16 x 2 24 Deep	170	62	M20 x 2.5 42 Deep	22	M20 x 80L	100	100
F0930	274	70	70	179	218	135	110	3	141	M16 x 2P 24 Deep	215	70	M20 x 2.5P 42 Deep	27	M20 x 80L	125	225
F1030	332	80	90	213.5	-	172	140	5	172	M20 x 2P 27 Deep	250	88	M20 x 2.5P 42 Deep	27	M20 x 80L	158	272

SIZE	N	N1	N2	øN3	N4	P	P1	P2	P3	P4	P6	S	S1	T	T3	V	V1	W	W1	X	X1	Y
F0830	117.5	265	210	60.2	66	320	170	26	20°	11°	8 holes, M12x1.75x20, 195 pcd 6 holes, M16x2Px27, 230 pcd	346	79	105	15	64.5	64	18	18	526	148	3
F0930	147.5	330	270	70.2	66	384	200	30	20°	11°	10 holes, M16x2Px27, 280 pcd	395	100	131	19	75	74	20	20	612	175	5
F1030	165	370	313	80.2	66	454	235	36	17°	10°		485	136	152	19.5	85	95	22	25	748	216	5.5

MOTORS		ALL SIZES					F0830		F0930		F1030	
		ko	g	g1	g2	g6	k	kb	k	kb	k	kb
MOTOR FRAME SIZE	80	230	158	118	190	200	532	582	610	660	670.5	720.5
	90S/L	270	177	149	218	200	582	641	650	709	710.5	769.5
	100/112	340	197	159	238	250	675	743	726	794	786.5	854.5
	132S/M	402	253	184	288	300	739	810	-	-	848.5	919.5
	160M/L/180M	538	314	230	*	350	905	*	-	-	1019.5	*
	180L	613	354	257	*	350	-	*	-	-	1094.5	*

* Consult Textron Power Transmission

SERIES F

DIMENSIONS

QUADRUPLE REDUCTION

9610

F			4	0				W	M
---	--	--	---	---	--	--	--	---	---

STANDARD UNIT

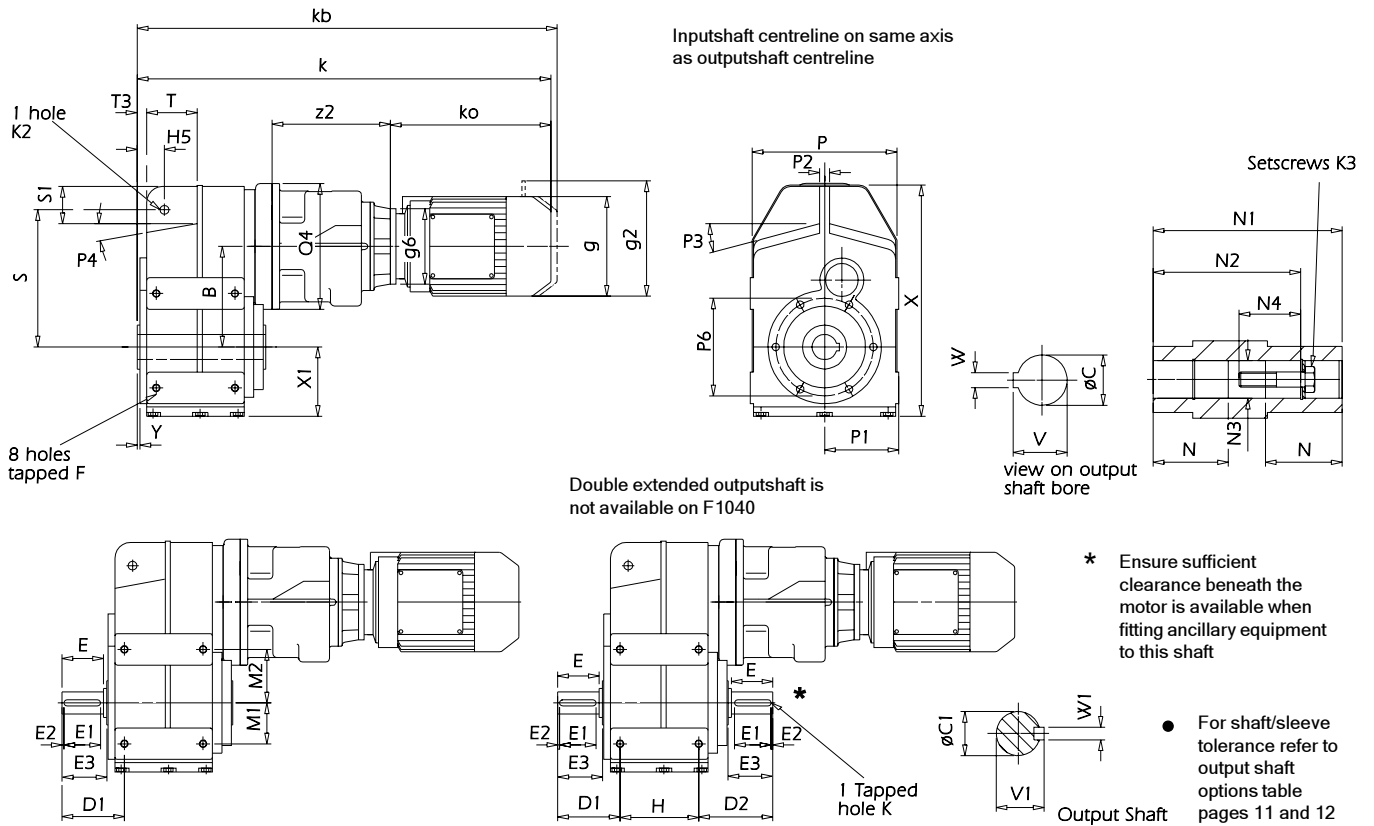

SIZE	B	øC	øC1	D1	D2	E	E1	E2	E3	F	H	H5	K	øK2	K3	M1	M2	N
F0640	160	40	35	99	118	66	58	3	71	M12x1.75x20	125	41	M16x2x36	14	M16x70L	65	85	90
F0740	200	50	50	121	146	86	80	3	91	M16x2x25	150	50	M16x2x36	22	M16x70L	85	115	105
F0840	226	60	60	155	180	114	100	3	120	M16x2x24	170	62	M20x2.5x42	22	M20x80L	100	100	117.5
F0940	274	70	70	179	218	135	110	3	141	M16 x 2Px42	215	70	M20 x 2.5Px42	27	M20x80L	125	225	147.5
F1040	332	80	90	213.5	-	172	140	5	172	M20 x 2Px27	250	88	M20 x 2.5Px42	27	M20x80L	158	272	165

SIZE	N1	N2	øN3	N4	P	P1	P2	P3	P4	P6	Q4	S	S1	T	T3	V	V1	W	W1	X	X1	Y
F0640	200	156	40.2	60	226	118	16	15°	10°	6 holes, M12x1.75x20, 150 pcd	200	218	59	80	13	43.5	40	12	10	367	110	2
F0740	235	183	50.2	60	266	140	20	20°	11°	6 holes, M12x1.75x20, 150 pcd	200	278	68	95	13	54	58.5	14	14	449	134	2
F0840	265	210	60.2	66	320	170	26	20°	11°	8 holes, M12x1.75x20, 195 pcd	250	346	79	105	15	64.5	71	18	18	526	148	3
F0940	330	270	70.2	66	384	200	30	20°	11°	6 holes, M16x2Px27, 230 pcd	300	395	100	131	19	75	74	20	20	612	175	5
F1040	370	313	80.2	66	454	235	36	17°	10°	10 holes, M16x2Px27, 280 pcd	350	485	136	152	19.5	85	95	22	25	748	216	5.5

MOTORS		ALL SIZES					F0640			F0740			F0840			F0940			F1040		
		ko	g	g1	g2	g6	k	kb	z2	k	kb	z2	k	kb	z2	k	kb	z2	k	kb	z2
MOTOR FRAME SIZE	63	185	122	101	160	140	566	608	169	608	650	169	696	738	210	-	-	-	-	-	-
	71	210	137	107	167	105	595	636	173	637	678	173	727	768	216	-	-	-	-	-	-
	80	230	158	118	190	120	630	680	188	672	722	188	747	797	216	859	909	269	996.5	1046.5	342
	90S/L	270	177	149	218	140	680	739	198	722	781	198	796	855	225	909	968	279	1036.5	1095.5	342
	100/112	340	197	159	238	160	-	-	-	800	868	206	910	978	269	1002	1070	302	1112.5	1180.5	348
	132	402	253	184	288	200	-	-	-	-	-	-	-	-	-	1066	1137	304	1174.5	1245.5	348
	160	538	314	230	*	350	-	-	-	-	-	-	-	-	-	1232	*	334	1340.5	*	378

* Consult Textron Power Transmission

SERIES F

DIMENSIONS

QUINTUPLE REDUCTION SIZES F06 & F07

9610

F	0	5	0			W	M
---	---	---	---	--	--	---	---

STANDARD UNIT QUINTUPLE REDUCTION

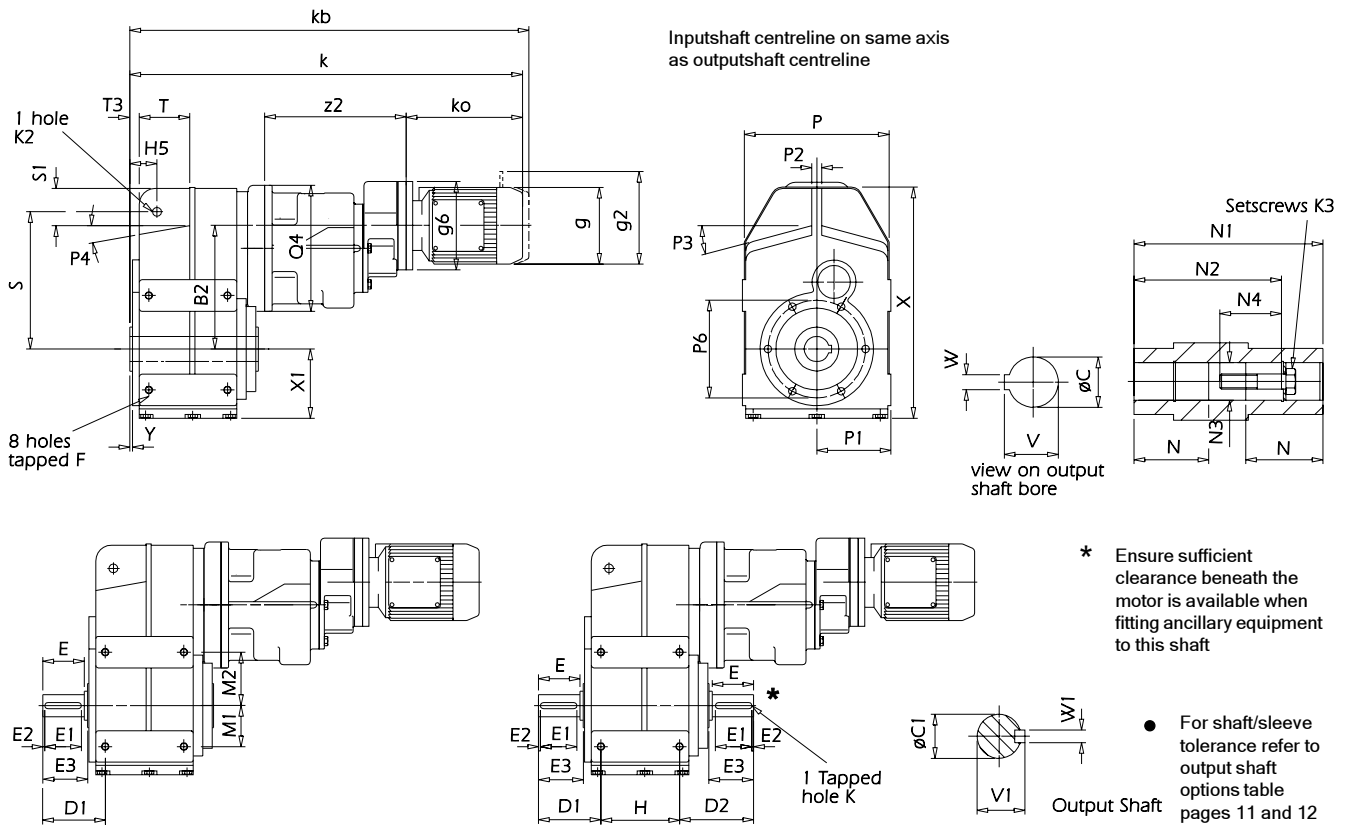

SIZE	B2	øC	øC1	D1	D2	E	E1	E2	E3	F	H	H5	K	øK2	K3	M1	M2	N
F0650	196	40	35	99	118	66	58	3	71	M12x1.75x20	125	41	M16x2x36	14	M16x70L	65	85	90
F0750	236	50	50	121	146	86	80	3	91	M16x2x25	150	50	M16x2x36	22	M16x70L	85	115	105

SIZE	N1	N2	øN3	N4	P	P1	P2	P3	P4	P6	Q4	S	S1	T	T3	V	V1	W	W1	X	X1	Y
F0650	200	156	40.2	66	226	118	16	15°	10°	6 holes, M12x1.75x20, 150 pcd	200	218	59	80	13	43.5	38	12	10	367	110	2
F0750	235	183	50.2	78	266	140	20	20°	11°	6 holes, M12x1.75x20, 150 pcd	200	278	68	95	13	54	53.5	14	14	449	134	2

MOTORS		ALL SIZES					F0650			F0750		
		ko	g	g1	g2	g6	k	kb	z2	k	kb	z2
MOTOR FRAME SIZE	63	185	122	101	160	140	622	664	225	664	706	225
	71	210	137	107	167	105	651	692	229	693	734	229

SERIES F

DIMENSIONS

QUINTUPLE REDUCTION SIZES F08, F09 & F10

9610

F		5	0			W	M
---	--	---	---	--	--	---	---

STANDARD UNIT

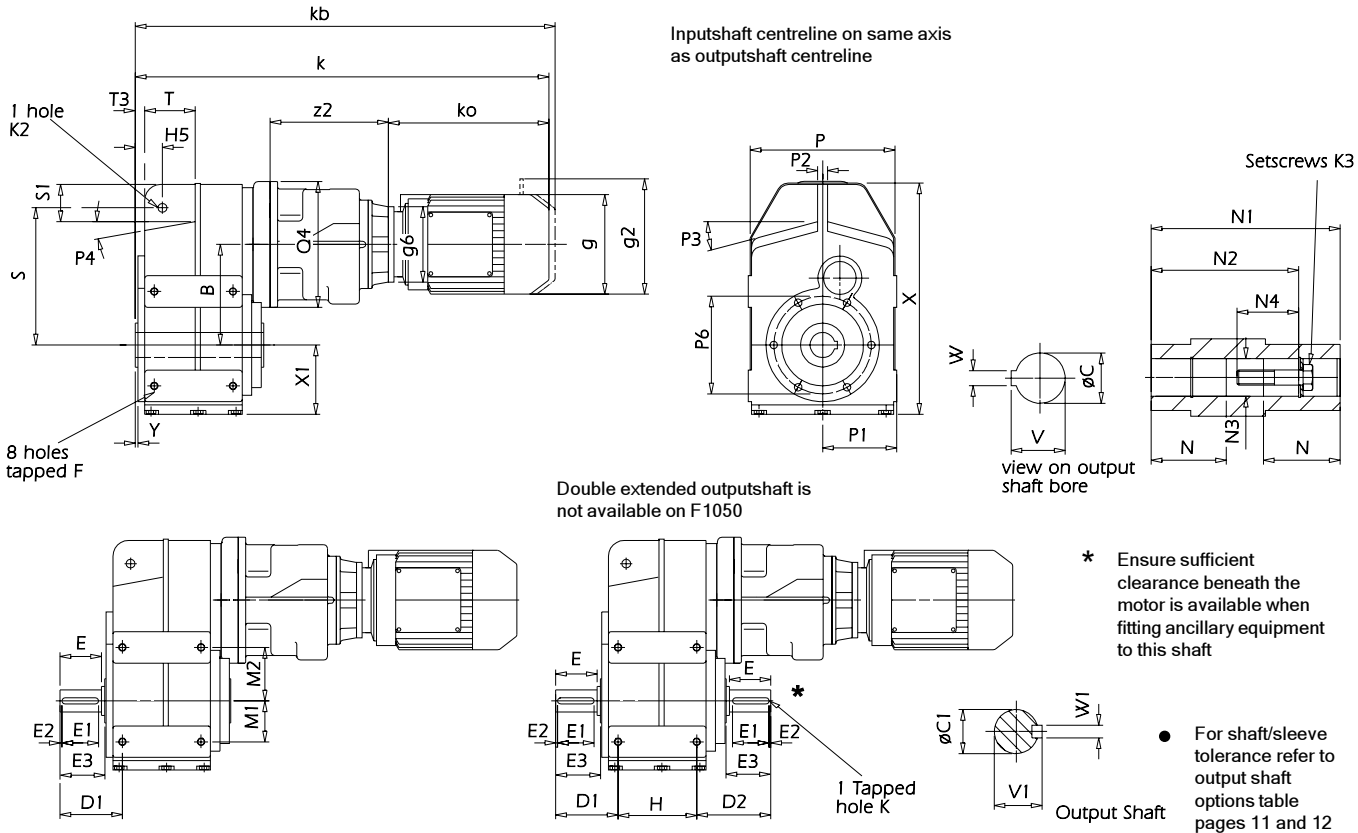

SIZE	B	øC	øC1	D1	D2	E	E1	E2	E3	F	H	H5	K	øK2	K3	M1	M2	N
F0850	226	60	60	155	180	114	100	3	120	M16x2x24	170	62	M20x2.5x42	22	M20x80L	100	100	117.5
F0950	274	70	70	179	218	135	110	3	141	M16 x 2P x 24	215	70	M20x2.5Px42	27	M20	125	225	147.5
F1050	332	80	90	213.5	-	172	140	5	172	M20 x 2P x 27	250	88	M20x2.5Px42	27	M24	158	272	165

SIZE	N1	N2	øN3	N4	P	P1	P2	P3	P4	P6	Q4	S	S1	T	T3	V	V1	W	W1	X	X1	Y
F0850	265	210	60.2	66	320	170	26	20°	11°	8 holes, M12x1.75x20, 195 pcd	250	346	79	105	15	64.5	64	18	18	526	148	3
F0950	330	270	70.2	66	384	200	30	20°	11°	6 holes, M16x2Px27, 230 pcd	200	395	100	131	19	75	74.5	20	20	612	175	5
F1050	370	313	80.2	66	454	235	36	17°	10°	10 holes, M16x2Px27, 200 pcd	200	485	136	152	19.5	85	95	22	25	748	216	5.5

MOTORS		ALL SIZES									F0850			F0950			F1050		
		ko	g	g1	g2	g6	k	kb	z2	k	kb	z2	k	kb	z2				
MOTOR FRAME SIZE	63	185	122	101	160	140	666	708	169	734	776	169	794.5	836.5	169				
	71	210	137	107	167	105	695	736	173	763	804	173	823.5	864.5	173				
	80	230	158	118	190	120	730	780	188	798	848	188	858.5	908.5	188				
	90S/L	270	177	149	218	140	780	839	198	848	907	198	908.5	967.5	198				
	100/112	340	197	159	238	160	858	926	206	926	994	206	986.5	1054.5	206				

SERIES F

DIMENSIONS

ALL UNITS

9703

F			0			B	M
---	--	--	---	--	--	---	---

STANDARD UNIT WITH FEET

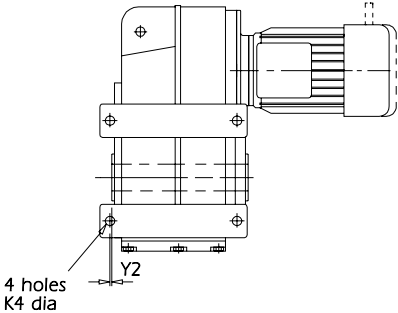

Inputshaft centreline on same axis
as outputshaft centreline

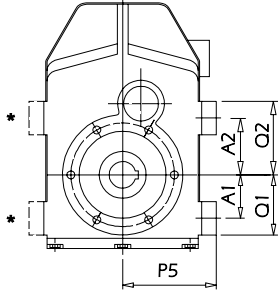

* Alternative feet position

Double extended outputshaft is not available on size F10

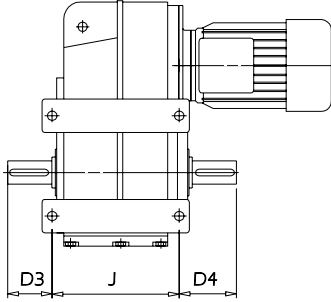
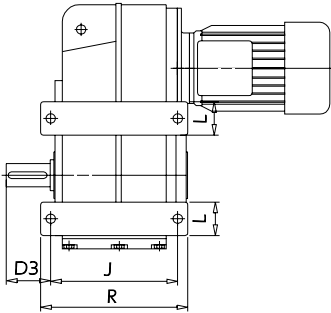

SIZE	A1	A2	D3	D4	J	K4	L	P5	Q1	Q2	R	Y2
F04	50	60	60	72	140	11	35	108	67.5	77.5	165	1
F06	65	85	66.5	85.5	190	14	50	140	90	110	220	4.5
F07	85	115	81	106	230	17.5	60	170	115	145	265	10
F08	100	110	112.5	137.5	255	17.5	60	200	130	130	290	7.5
F09	125	225	136.5	175.5	300	17.5	60	230	155	255	335	4.5
F10	158	272	163.5	-	350	22	75	270	195.5	309.5	400	8.5

SERIES F

DIMENSIONS

ALL UNITS

9706

F			0			F	M
---	--	--	---	--	--	---	---

STANDARD UNIT WITH FLANGE

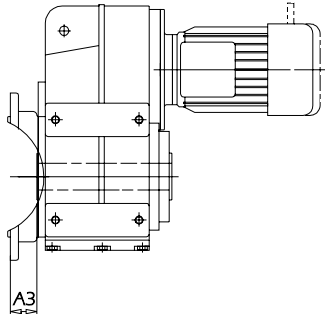

Inputshaft centreline on same axis as outputshaft centreline

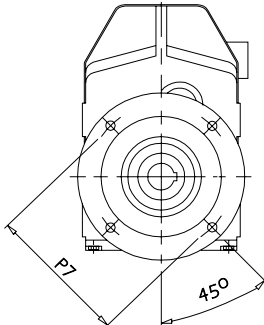

Sizes F04, F06, F07 & F08

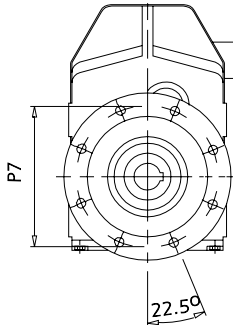

Sizes F09 & F10

Double extended outputshaft is not available on size F10

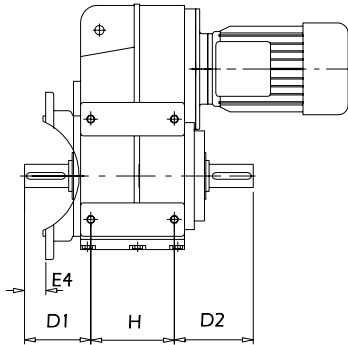
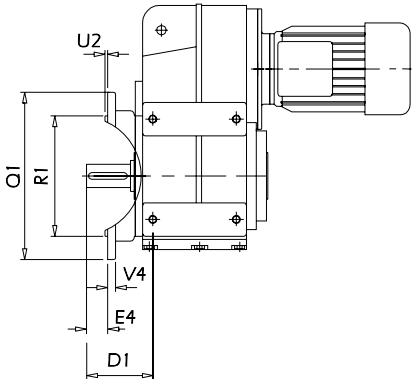

SIZE	A3	D1	D2	E4	H	P7	øQ1	øR1	U2	V4
F04	42	85	97	19	90	4 holes, 11 dia on a 165 pcd	200	130 j6	3.5	12
F06	39.5	99	118	31.5	125	4 holes, 14 dia on a 215 pcd	250	180 j6	4	12
F07	39.5	121	146	51.5	150	4 holes, 14 dia on 215 pcd	250	180 j6	4	12
F08	47	155	180	73	170	4 holes, 18 dia on a 300 pcd	350	250 h6	5	18
F09	51	179	218	90	215	8 holes, 18 dia on a 400 pcd	450	350 h6	5	20
F10	60	213.5	-	112	250	8 holes, 18 dia on a 400 pcd	450	350 h6	5	22

SERIES F

MOTORISED BACKSTOP MODULE

0203

Motorised backstop modules can be fitted between the gear unit and motor. The backstop device incorporates high quality centrifugal lift off sprags which are wear free above the lift off speed (n min). To ensure correct operation motor speed must exceed lift off speed.

Suitable for ambient temperature -40°C to + 50°C

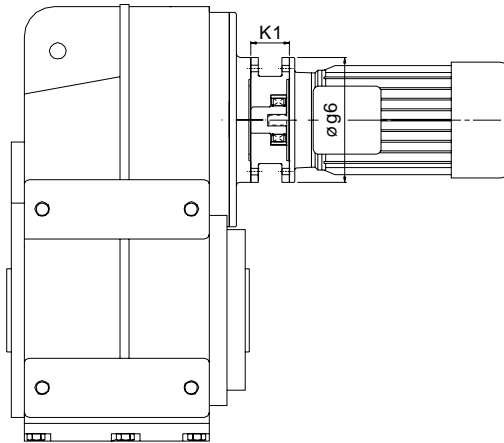

Warning

Removal of motor or backstop will release the drive. Ensure all driven machinery is secure prior to any maintenance work

IEC B5 FLANGE

Motor Frame Size	Lift off Speed ('n' min) (rev/min)	Rated Locking Torque ('T max') (at motor) (Nm)	øg6	K1
100	670	170	250	70
112	670	170	250	70
132	620	940	300	95
160	620	940	350	130
180	620	940	350	130
200	550	1260	400	130

NEMA C FLANGE

Motor Frame Size	Lift off Speed ('n' min) (rev/min)	Rated Locking Torque ('T max') (at motor) (Nm)	øg6	K1
182TC / 184TC	670	300	228	95.25
213TC / 215 TC	670	300	228	95.25
254TC / 256TC	620	940	228	120.65
284TC / 286TC	620	940	280	136.50
324TC / 326TC	550	1260	330	152.4

When a backstop module is fitted dimension K1 should be added to the overall length of the geared motor assembly.

Rotation of outputshaft must be specified when ordering as viewed from the outputshaft end (as shown in the diagram)

- | | | | | |
|----|---|---------------|---|---------------|
| CW | - | Free Rotation | - | Clockwise |
| | | Locked | | Anticlockwise |
| AC | - | Free Rotation | - | Anticlockwise |
| | | Locked | | Clockwise |

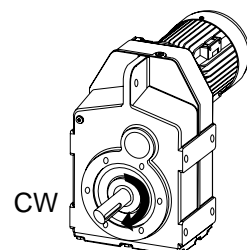

SERIES F

NOTES

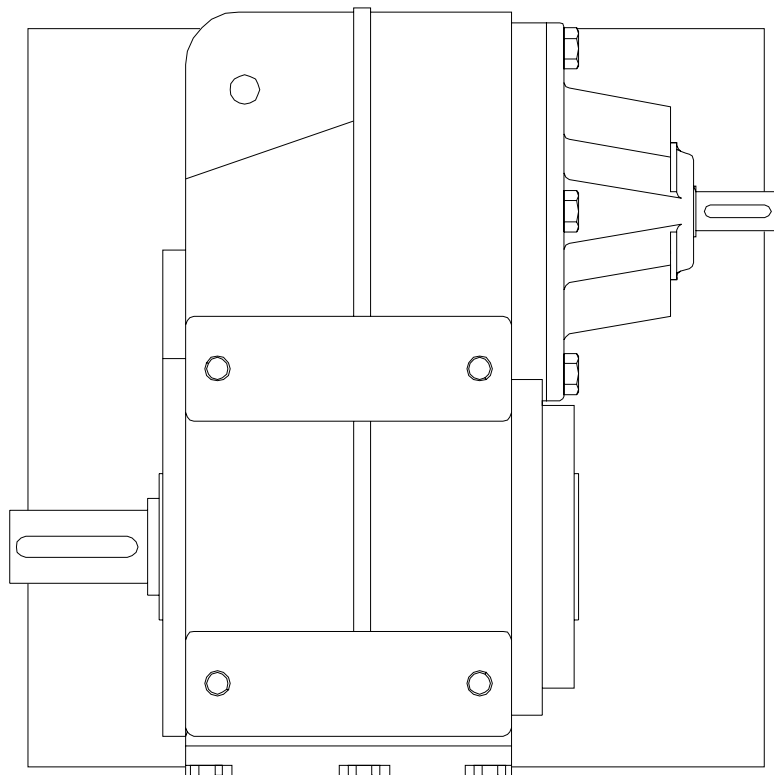

REDUCER SERIES F

OVERHUNG LOADS (NEWTONS) ON OUTPUT SHAFTS

9608

Maximum permissible overhung loads

When a sprocket, gear etc. is mounted on the shaft a calculation, as below, must be made to determine the overhung load on the shaft, and the results compared to the maximum permissible overhung loads tabulated. Overhung loads can be reduced by increasing the diameter to the sprocket, gear, etc. If the maximum permissible overhung load is exceeded, the sprocket, gear, etc. should be mounted on a separate shaft, flexibly coupled and supported in its own bearings, or the gear unit shaft should be extended to run in an outboard bearing. Alternatively, a larger gear is often a less expensive solution.

Permissible overhung loads vary according to the direction of rotation. The values tabulated are for the most unfavourable direction with the unit transmitting full rated power and the load P applied midway along the shaft extension. Hence they can sometimes be increased for a more favourable direction of rotation, or if the power transmitted is less than the rated capacity of the gear unit, or if the load is applied nearer to the gear unit case. Refer to Textron Power Transmission for further details. In any event, the sprocket, gear etc. should be positioned as close as possible to the gear unit case in order to reduce bearing loads and shaft stresses, and to prolong life.

Overhung load (Newtons)

$$P = \frac{\text{kW} \times 9,500,000 \times K}{N \times R}$$

where

- P = equivalent overhung load (Newtons)
- KW = power transmitted by the shaft (kilowatts)
- N = speed of shaft (rev/min)
- R = pitch radius of sprocket, etc. (mm)
- K = factor

Overhung member	K (factor)
Chain sprocket*	1.00
Spur or helical pinion	1.25
Vee belt sheave	1.50
Flat belt pulley	2.00

* If multistrand chain drives are equally loaded and the outer stand is further than dimension A output or B input refer to Textron Power Transmission.

Note: 1 Newton = 0.10197 kg = 0.2248 lbs.

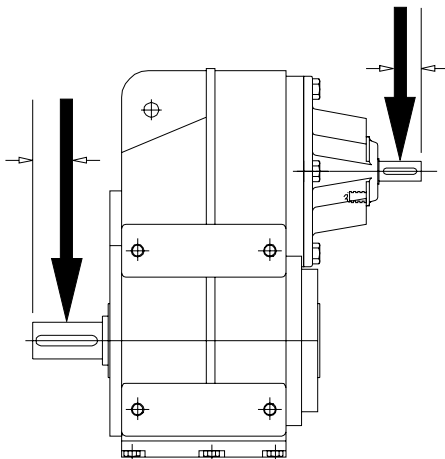

Distance midway along the shaft extension

Size of unit	No. of Reductions	Dimension A (mm)	Dimension B (mm)
F04	2 - 3	28.5	20
F06	2 - 5	33	20
F07	2	43	25
	3 - 5	43	20
F08	2	57	30
	3	57	25
	4 - 5	57	20
F09	2	67.5	40
	3	67.5	30
	4	67.5	25
	5	67.5	20
F10	2	86	55
	3	86	40
	4	86	30
	5	86	20

Axial Thrust Capacities (Newtons)

Permissible axial thrust capacities vary according to the direction of rotation and the direction of thrust, towards or away from the unit. The values tabulated are for the most unfavourable direction and hence can sometimes be increased. Similarly they can sometimes be increased if the power transmitted is less than the rated capacity of the gear unit.

Thrust capacities tabulated refer to outputshafts, and are calculated without any overhung loads being applied. In cases where combined axial thrusts and overhung loads are to be applied, refer to Textron Power Transmission.

SERIES F

OVERHUNG LOADS (NEWTONS) & AXIAL THRUSTS (NEWTONS)

9608

REDUCER OVERHUNG LOADS (Fra) & AXIAL THRUST CAPACITIES ON OUTPUTSHAFT

		OUTPUT REV/MIN							
		280	200	160	100	63	40	25	2.5 & Under
F0420 F0430	OHL (Fra)	3090	3090	3250	3670	4380	5200	6410	6410
	THRUST	5160	5300	5340	5340	5340	5340	5340	5340
F0620 F0630	OHL (Fra)	6150	6150	6340	7220	9460	11400	13800	14200
	THRUST	9600	9820	10300	12600	12600	12600	12600	12600
F0720 F0730	OHL (Fra)	9100	9100	9100	9640	11300	12600	15200	18500
	THRUST	14200	14500	14500	16800	17000	17000	17000	17000
F0820 F0830	OHL (Fra)	8280	8280	8280	9240	10700	12500	16300	18500
	THRUST	14200	14200	14200	17300	18800	18800	18800	18800
F0920 F0930	OHL (Fra)	32900	32900	32900	32900	32900	32900	32900	32900
	THRUST	33400	33400	33400	33400	33400	33400	33400	33400
F1020 F1030	OHL (Fra)	43300	43300	43300	43300	43300	43300	43300	43300
	THRUST	42800	42800	42800	42800	42800	42800	42800	42800

REDUCER OVERHUNG LOADS (Frb) ON INPUTSHAFT

AT 1450 rev/min

		RATIO	SIZE				
			F04	F06	F07	F08	F09
DOUBLE REDUCTION UNIT	5.0	1360	1090	2110	2000	3050	4870
	7.1	1360	1090	2110	2000	3050	4870
	9.0	1360	1090	2110	2000	3050	4870
	14.0	1360	1450	2110	2000	3890	5140
	22.0	1360	1450	2110	2850	3910	5140
	36.0	1430	1450	2110	2930	4080	5140
	56.0	1430	1690	2120	2930	4160	5140
	80.0	1540	1810	2440	3250	4160	5340
TRIPLE REDUCTION UNIT	100.0	1560	1920	2530	3670	4280	5340
	63.0	1630	1530	1800	-	-	-
	100.0	1650	1570	1800	2510	3850	4690
	160.0	1660	1580	1830	2550	3910	4760
	250.0	1680	1600	1850	2580	3940	4810
	355.0	1690	1650	1920	2660	4050	4860
QUADRUPLE REDUCTION UNIT ALL RATIOS	-	1720	1720	1800	2350	3500	
QUINTUPLE REDUCTION UNIT ALL RATIOS	-	1840	1840	1840	1840	1840	

SERIES F

MOMENTS OF INERTIA

9608

MOMENTS OF INERTIA (Kg cm²) Referred to Input Shaft

DOUBLE REDUCTION

RATIO	F0420	F0620	F0720	F0820	F0920	F1020
5.01	4.23	18.89	44.20	103.24	278.37	611.92
6.31	3.55	16.02	35.83	88.29	233.10	501.00
7.11	2.55	11.03	25.99	62.01	174.92	366.28
8.01	2.23	9.31	21.79	53.69	150.41	324.08
9.01	1.87	7.88	19.17	46.63	129.83	270.56
10.00	1.94	8.15	18.33	47.66	131.40	276.02
11.00	1.39	5.71	13.15	33.81	97.62	189.83
12.00	1.22	4.87	11.18	29.50	84.75	169.03
14.00	1.25	5.14	11.48	30.89	88.54	167.88
16.00	1.11	4.43	9.88	27.19	77.47	150.19
18.00	0.93	3.40	8.11	20.37	61.20	109.20
20.00	0.84	2.92	6.95	17.76	54.13	93.90
22.00	0.87	3.16	7.31	19.16	57.41	100.34
25.00	0.80	2.75	6.26	16.87	51.22	86.99
28.00	0.67	2.18	4.87	13.36	40.73	69.98
32.00	0.65	2.07	4.37	12.06	37.23	62.63
36.00	0.65	2.09	4.60	12.89	39.28	66.30
40.00	0.63	2.00	4.16	11.69	36.06	59.65
45.00	0.56	1.65	3.56	9.32	30.29	47.51
50.00	0.55	1.58	3.40	8.91	28.70	43.31
56.00	0.55	1.61	3.46	9.14	29.70	46.04
63.00	0.54	1.55	3.31	8.75	28.22	42.20
71.00	0.52	1.42	3.01	7.73	25.24	38.47
80.00	0.51	1.37	2.89	7.54	24.63	36.65
90.00	0.52	1.41	2.96	7.64	24.98	37.86
100.00	0.51	1.36	2.86	7.48	24.43	36.12

TRIPLE REDUCTION

RATIO	F0430	F0630	F0730	F0830	F0930	F1030
63.00	0.59	0.93	2.69	-	-	-
71.00	0.57	0.85	2.36	-	-	-
80.00	0.59	0.92	2.63	-	-	-
90.00	0.57	0.83	2.32	-	-	-
100.00	0.53	0.68	1.86	8.55	23.39	53.01
112.00	0.52	0.65	1.79	7.52	20.43	47.48
125.00	0.53	0.67	1.84	8.51	23.28	52.73
140.00	0.52	0.65	1.77	7.50	20.34	47.26
160.00	0.50	0.56	1.50	5.30	14.61	36.30
180.00	0.50	0.55	1.45	4.96	13.23	33.03
200.00	0.50	0.56	1.49	5.28	14.57	36.19
225.00	0.50	0.55	1.44	4.95	13.19	32.95
250.00	0.49	0.52	1.35	3.97	10.21	29.50
280.00	0.49	0.51	1.31	3.84	9.70	27.89
315.00	0.49	0.52	1.34	3.97	10.19	29.45
355.00	0.48	0.51	1.31	3.84	9.69	27.85

SERIES F

MOMENTS OF INERTIA

9608

QUADRUPLE REDUCTION

RATIO	F0640	F0740	F0840	F0940	F1040
360.00	0.66	1.06	2.70	7.06	18.11
400.00	0.66	0.91	2.38	6.07	16.09
450.00	0.64	0.83	2.50	6.46	17.46
500.00	0.64	0.84	2.23	5.61	15.62
560.00	0.62	0.77	1.86	4.51	12.48
630.00	0.56	0.67	1.79	4.09	11.37
710.00	0.54	0.64	1.79	4.29	12.23
800.00	0.66	0.64	1.73	3.92	11.17
900.00	0.63	0.62	2.65	6.91	17.83
1000.00	0.64	0.67	2.34	5.95	15.89
1100.00	0.62	0.64	2.47	6.37	17.29
1200.00	0.56	0.64	2.20	5.54	15.49
1400.00	0.54	0.62	1.84	4.46	12.37
1600.00	0.55	0.56	1.78	4.05	11.28
1800.00	0.53	0.54	1.78	4.26	12.16
2000.00	0.54	0.55	1.72	3.89	11.12
2200.00	0.53	0.54	1.49	3.39	8.93
2500.00	0.51	0.54	1.45	3.26	8.58
2800.00	0.51	0.53	1.47	3.31	8.85
3200.00	0.50	0.51	1.45	3.19	8.51
3600.00	0.51	0.51	1.41	3.27	8.77
4000.00	0.50	0.51	1.33	3.15	8.44
4500.00	0.51	0.51	1.30	2.90	7.37
5000.00	0.51	0.51	1.33	2.88	7.47
5600.00	0.50	0.51	1.30	2.79	7.35

QUINTUPLE REDUCTION

RATIO	F0650	F0750	F0850	F0950	F1050
4500.00	0.50	0.53	-	-	-
5000.00	0.50	0.52	-	-	-
5600.00	0.50	0.50	-	-	-
6300.00	0.50	0.50	0.62	0.66	0.70
7100.00	0.50	0.50	0.56	0.63	0.67
8000.00	0.50	0.50	0.54	0.57	0.60
9000.00	0.49	0.50	0.55	0.55	0.58
10000.00	0.48	0.50	0.54	0.56	0.58
11000.00	0.49	0.49	0.54	0.54	0.56
12000.00	0.48	0.48	0.53	0.55	0.56
14000.00	0.49	0.49	0.52	0.53	0.54
16000.00	0.48	0.48	0.51	0.51	0.52
18000.00	0.49	0.49	0.51	0.51	0.52
20000.00	0.48	0.48	0.51	0.51	0.51

GD² (Kg cm²) = 4 x Moment of Inertia (Kg cm²)

SERIES F

RATINGS AT 2900 RPM INPUT

9608

DOUBLE REDUCTION

NOMINAL RATIO	NOMINAL OUTPUT SPEED REV / MIN	CAPACITY	SIZES OF UNIT					
			F0420	F0620	F0720	F0820	F0920	F1020
5.0	578.84	Input kW	CONSULT TEXTRON POWER TRANSMISSION					
		Output Torque Nm						
6.3	459.59	Input kW						
		Output Torque Nm						
7.1	407.88	Input kW						
		Output Torque Nm						
8.0	362.05	Input kW						
		Output Torque Nm						
9.0	321.86	Input kW						
		Output Torque Nm						
10.	290.00	Input kW						
		Output Torque Nm						
11.	263.64	Input kW						
		Output Torque Nm						
12.	241.67	Input kW						
		Output Torque Nm						
14.	207.14	Input kW						
		Output Torque Nm						
16.	181.25	Input kW						
		Output Torque Nm						
18.	161.11	Input kW						
		Output Torque Nm						
20.	145.00	Input kW						
		Output Torque Nm						
22.	131.82	Input kW	4.34	10.50	15.40	26.20	45.60	61.20
		Output Torque Nm	302.	735.	1070.	1820.	3300.	4440.
25.	116.00	Input kW	4.02	9.27	14.20	23.90	42.10	56.60
		Output Torque Nm	317.	756.	1130.	1940.	3470.	4650.
28.	103.57	Input kW	3.07	8.34	12.50	19.70	35.50	52.80
		Output Torque Nm	281.	772.	1150.	1790.	3220.	4730.
32.	90.63	Input kW	3.04	7.91	11.20	17.80	32.30	49.30
		Output Torque Nm	303.	782.	1160.	1830.	3250.	4910.
36.	80.56	Input kW	3.07	6.77	11.40	19.70	33.80	46.60
		Output Torque Nm	348.	780.	1300.	2190.	3960.	5240.
40.	72.50	Input kW	2.91	6.38	10.50	17.80	31.60	43.50
		Output Torque Nm	359.	784.	1350.	2240.	4100.	5440.
45.	64.44	Input kW	2.36	5.60	8.62	13.20	24.30	39.30
		Output Torque Nm	338.	809.	1230.	1910.	3460.	5570.
50.	58.00	Input kW	1.85	5.01	7.97	12.30	22.30	35.80
		Output Torque Nm	298.	792.	1250.	1950.	3500.	5850.
56.	51.79	Input kW	2.10	4.48	8.53	13.20	23.00	34.60
		Output Torque Nm	372.	804.	1520.	2340.	4220.	6160.
63.	46.03	Input kW	1.85	4.10	7.97	12.30	20.80	31.50
		Output Torque Nm	369.	805.	1550.	2390.	4220.	6460.
71.	40.85	Input kW	1.22	2.48	4.31	9.47	16.80	27.90
		Output Torque Nm	259.	534.	930.	2020.	3610.	6160.
80.	36.25	Input kW	1.04	1.58	3.19	7.61	14.90	23.70
		Output Torque Nm	251.	380.	762.	1860.	3610.	5600.
90.	32.22	Input kW	1.22	2.48	4.31	9.47	15.20	25.60
		Output Torque Nm	320.	664.	1160.	2470.	4220.	7080.
100	29.00	Input kW	1.04	1.58	3.19	7.61	13.50	23.70
		Output Torque Nm	310.	472.	949.	2280.	4220.	7040.

■ Input mechanical rating exceeds thermal capacity, check thermal power page 108

SERIES F

RATINGS AT 2900 RPM INPUT

9608

TRIPLE REDUCTION

NOMINAL RATIO	NOMINAL OUTPUT SPEED REV / MIN	CAPACITY	SIZES OF UNIT					
			F0430	F0630	F0730	F0830	F0930	F1030
63.	46.03	Input kW	1.88	3.75	5.82	*	*	*
		Output Torque Nm	378.	752.	1160.	*	*	*
71.	40.85	Input kW	1.65	3.46	5.28	*	*	*
		Output Torque Nm	378.	789.	1230.	*	*	*
80.	36.25	Input kW	1.56	3.23	5.82	*	*	*
		Output Torque Nm	386.	805.	1450.	*	*	*
90.	32.22	Input kW	1.36	2.84	5.28	*	*	*
		Output Torque Nm	386.	805.	1530.	*	*	*
100	29.00	Input kW	1.22	2.47	4.19	7.99	13.00	16.70
		Output Torque Nm	378.	811.	1370.	2580.	4190.	5380.
112	25.89	Input kW	1.04	2.28	4.00	7.31	12.00	15.40
		Output Torque Nm	378.	811.	1400.	2670.	4310.	5530.
125	23.20	Input kW	1.01	1.98	4.19	6.92	10.20	16.70
		Output Torque Nm	386.	806.	1710.	2740.	4220.	6760.
140	20.71	Input kW	0.86	1.82	3.95	6.21	9.20	15.40
		Output Torque Nm	386.	806.	1720.	2770.	4220.	6950.
160	18.13	Input kW	0.75	1.59	3.07	5.38	8.55	11.90
		Output Torque Nm	378.	811.	1570.	2780.	4310.	6080.
180	16.11	Input kW	0.68	1.41	2.86	4.90	7.73	10.70
		Output Torque Nm	378.	811.	1600.	2780.	4310.	6290.
200	14.50	Input kW	0.62	1.27	2.70	4.42	6.51	11.30
		Output Torque Nm	386.	806.	1720.	2790.	4220.	7250.
225	12.89	Input kW	0.56	1.13	2.47	4.02	5.89	9.79
		Output Torque Nm	386.	806.	1720.	2790.	4220.	7250.
250	11.60	Input kW	0.46	1.07	2.18	3.66	5.63	8.03
		Output Torque Nm	352.	811.	1660.	2780.	4310.	6400.
280	10.36	Input kW	0.39	0.94	1.58	3.19	5.02	7.49
		Output Torque Nm	341.	811.	1350.	2780.	4310.	6400.
315	9.21	Input kW	0.40	0.85	1.81	3.00	4.29	7.25
		Output Torque Nm	386.	806.	1720.	2790.	4220.	7250.
355	8.17	Input kW	0.36	0.75	1.58	2.62	3.82	6.76
		Output Torque Nm	386.	806.	1680.	2790.	4220.	7250.

* These ratios are not available on sizes F0830, F0930 and F1030

SERIES F

RATINGS AT 1750 RPM INPUT

9608

DOUBLE REDUCTION

NOMINAL RATIO	NOMINAL OUTPUT SPEED REV / MIN	CAPACITY	SIZES OF UNIT					
			F0420	F0620	F0720	F0820	F0920	F1020
5.0	349.30	Input kW	6.22	15.00	15.50	31.80	68.90	92.50
		Output Torque Nm	168.	402.	422.	854.	1850.	2500.
6.3	277.34	Input kW	5.81	13.90	15.50	31.80	61.80	84.00
		Output Torque Nm	194.	462.	526.	1050.	2140.	2860.
7.1	246.13	Input kW	5.48	13.00	15.50	31.80	59.70	79.90
		Output Torque Nm	208.	491.	586.	1210.	2210.	3020.
8.0	218.48	Input kW	5.23	12.40	15.50	31.10	56.50	76.70
		Output Torque Nm	219.	522.	659.	1320.	2350.	3160.
9.0	194.23	Input kW	4.90	11.70	15.50	29.50	53.40	72.00
		Output Torque Nm	233.	555.	725.	1390.	2490.	3370.
10.	175.00	Input kW	4.75	11.30	15.50	28.50	50.20	69.00
		Output Torque Nm	245.	595.	821.	1480.	2690.	3570.
11.	159.09	Input kW	4.31	10.40	15.10	25.90	46.90	62.70
		Output Torque Nm	260.	624.	921.	1580.	2820.	3820.
12.	145.83	Input kW	4.04	9.70	14.10	24.30	44.00	60.00
		Output Torque Nm	277.	662.	977.	1670.	2960.	3940.
14.	125.00	Input kW	3.89	9.44	13.70	23.60	41.30	56.00
		Output Torque Nm	290.	706.	1040.	1760.	3200.	4280.
16.	109.38	Input kW	3.63	8.81	12.70	22.10	38.70	53.50
		Output Torque Nm	308.	748.	1100.	1860.	3350.	4410.
18.	97.22	Input kW	3.39	6.41	12.00	19.90	36.40	48.40
		Output Torque Nm	317.	600.	1110.	1880.	3400.	4640.
20.	87.50	Input kW	3.15	6.05	11.00	18.00	33.10	44.80
		Output Torque Nm	333.	658.	1170.	1980.	3530.	4870.
22.	79.55	Input kW	3.04	6.41	10.80	18.30	31.90	42.90
		Output Torque Nm	351.	747.	1250.	2120.	3840.	5170.
25.	70.00	Input kW	2.76	5.84	9.92	16.80	29.50	39.70
		Output Torque Nm	361.	791.	1310.	2260.	4040.	5410.
28.	62.50	Input kW	1.85	5.19	8.87	12.70	25.30	37.00
		Output Torque Nm	282.	797.	1350.	1910.	3810.	5500.
32.	54.69	Input kW	1.83	4.93	8.01	11.00	23.00	34.50
		Output Torque Nm	303.	809.	1380.	1880.	3850.	5710.
36.	48.61	Input kW	1.85	4.21	7.96	12.70	21.70	32.60
		Output Torque Nm	348.	805.	1510.	2340.	4220.	6100.
40.	43.75	Input kW	1.83	3.95	7.36	11.00	19.60	30.50
		Output Torque Nm	375.	805.	1580.	2300.	4220.	6330.
45.	38.89	Input kW	1.44	3.38	6.16	8.76	17.40	27.20
		Output Torque Nm	341.	810.	1460.	2110.	4100.	6400.
50.	35.00	Input kW	1.12	3.04	5.69	7.61	15.90	23.60
		Output Torque Nm	299.	797.	1480.	2010.	4150.	6400.
56.	31.25	Input kW	1.31	2.71	5.82	8.76	13.90	24.20
		Output Torque Nm	386.	805.	1720.	2580.	4220.	7170.
63.	27.78	Input kW	1.12	2.47	5.32	7.61	12.60	21.30
		Output Torque Nm	369.	805.	1720.	2460.	4220.	7250.
71.	24.65	Input kW	0.74	1.50	2.60	6.52	11.10	16.90
		Output Torque Nm	261.	534.	931.	2300.	3950.	6170.
80.	21.88	Input kW	0.63	0.95	1.92	4.41	9.13	14.30
		Output Torque Nm	251.	380.	763.	1790.	3660.	5610.
90.	19.44	Input kW	0.74	1.50	2.60	6.38	9.17	15.80
		Output Torque Nm	323.	665.	1160.	2760.	4220.	7250.
100	17.50	Input kW	0.63	0.95	1.92	4.41	8.17	14.30
		Output Torque Nm	310.	473.	950.	2190.	4220.	7040.

Input mechanical rating exceeds thermal capacity, check thermal power page 108

SERIES F

RATINGS AT 1750 RPM INPUT

9608

TRIPLE REDUCTION

NOMINAL RATIO	NOMINAL OUTPUT SPEED REV / MIN	CAPACITY	SIZES OF UNIT					
			F0430	F0630	F0730	F0830	F0930	F1030
63.	27.78	Input kW	1.13	2.43	3.95	*	*	*
		Output Torque Nm	378.	811.	1310.	*	*	*
71.	24.65	Input kW	0.99	2.14	3.58	*	*	*
		Output Torque Nm	378.	811.	1380.	*	*	*
80.	21.88	Input kW	0.94	1.95	3.95	*	*	*
		Output Torque Nm	386.	806.	1630.	*	*	*
90.	19.44	Input kW	0.82	1.71	3.58	*	*	*
		Output Torque Nm	386.	806.	1720.	*	*	*
100	17.50	Input kW	0.74	1.49	2.85	5.16	8.06	11.40
		Output Torque Nm	378.	811.	1550.	2780.	4310.	6100.
112	15.63	Input kW	0.63	1.37	2.72	4.57	7.25	10.50
		Output Torque Nm	378.	811.	1580.	2780.	4310.	6250.
125	14.00	Input kW	0.61	1.19	2.54	4.23	6.14	10.80
		Output Torque Nm	386.	806.	1720.	2790.	4220.	7250.
140	12.50	Input kW	0.52	1.10	2.38	3.75	5.53	9.68
		Output Torque Nm	386.	806.	1720.	2790.	4220.	7250.
160	10.94	Input kW	0.45	0.96	1.96	3.24	5.14	7.52
		Output Torque Nm	378.	811.	1660.	2780.	4310.	6400.
180	9.72	Input kW	0.41	0.85	1.79	2.95	4.65	6.53
		Output Torque Nm	378.	811.	1660.	2780.	4310.	6400.
200	8.75	Input kW	0.37	0.76	1.63	2.66	3.92	6.79
		Output Torque Nm	386.	806.	1720.	2790.	4220.	7250.
225	7.78	Input kW	0.34	0.68	1.49	2.42	3.54	5.89
		Output Torque Nm	386.	806.	1720.	2790.	4220.	7250.
250	7.00	Input kW	0.28	0.64	1.31	2.20	3.39	4.84
		Output Torque Nm	353.	812.	1660.	2780.	4310.	6400.
280	6.25	Input kW	0.24	0.57	0.95	1.92	3.02	4.51
		Output Torque Nm	342.	816.	1350.	2780.	4310.	6400.
315	5.56	Input kW	0.25	0.52	1.09	1.81	2.58	4.37
		Output Torque Nm	388.	806.	1720.	2790.	4230.	7250.
355	4.93	Input kW	0.22	0.45	0.95	1.58	2.30	4.07
		Output Torque Nm	388.	806.	1680.	2790.	4230.	7250.

* These ratios are not available on sizes F0830, F0930 and F1030

SERIES F

RATINGS AT 1450 RPM INPUT

9608

DOUBLE REDUCTION

NOMINAL RATIO	NOMINAL OUTPUT SPEED REV / MIN	CAPACITY	SIZES OF UNIT					
			F0420	F0620	F0720	F0820	F0920	F1020
5.0	289.42	Input kW	5.15	12.80	12.90	26.40	60.30	78.20
		Output Torque Nm	168.	412.	422.	855.	1960.	2560.
6.3	229.79	Input kW	5.09	12.20	12.90	26.40	54.10	73.60
		Output Torque Nm	205.	489.	526.	1050.	2270.	3020.
7.1	203.94	Input kW	4.80	11.40	12.90	26.40	52.30	70.00
		Output Torque Nm	220.	519.	587.	1220.	2340.	3200.
8.0	181.02	Input kW	4.58	10.80	12.90	26.40	49.50	67.20
		Output Torque Nm	231.	553.	660.	1350.	2490.	3340.
9.0	160.93	Input kW	4.29	10.20	12.90	25.90	46.80	63.10
		Output Torque Nm	246.	582.	726.	1470.	2640.	3560.
10.	145.00	Input kW	4.16	9.93	12.90	25.00	43.90	60.40
		Output Torque Nm	260.	629.	822.	1570.	2840.	3770.
11.	131.82	Input kW	3.78	9.08	12.90	22.70	41.10	55.00
		Output Torque Nm	275.	660.	949.	1670.	2990.	4040.
12.	120.83	Input kW	3.54	8.50	12.30	21.30	38.60	52.50
		Output Torque Nm	293.	700.	1030.	1760.	3130.	4170.
14.	103.57	Input kW	3.41	8.27	12.00	20.70	36.20	49.00
		Output Torque Nm	307.	747.	1100.	1870.	3390.	4530.
16.	90.63	Input kW	3.18	7.53	11.20	19.40	33.90	46.80
		Output Torque Nm	326.	771.	1160.	1970.	3550.	4670.
18.	80.56	Input kW	2.97	5.31	10.50	17.50	32.00	42.40
		Output Torque Nm	335.	601.	1170.	2000.	3610.	4910.
20.	72.50	Input kW	2.76	5.01	9.66	15.80	29.20	39.30
		Output Torque Nm	353.	659.	1240.	2110.	3760.	5150.
22.	65.91	Input kW	2.61	5.31	9.46	16.10	28.00	37.60
		Output Torque Nm	363.	747.	1320.	2250.	4060.	5470.
25.	58.00	Input kW	2.33	4.92	8.69	14.70	25.50	34.80
		Output Torque Nm	368.	804.	1390.	2390.	4220.	5730.
28.	51.79	Input kW	1.53	4.30	7.78	10.50	22.30	32.40
		Output Torque Nm	282.	797.	1430.	1910.	4060.	5820.
32.	45.31	Input kW	1.52	4.09	7.05	9.13	20.30	30.30
		Output Torque Nm	303.	810.	1470.	1880.	4110.	6040.
36.	40.28	Input kW	1.53	3.49	6.98	10.50	18.00	28.60
		Output Torque Nm	348.	805.	1600.	2350.	4220.	6460.
40.	36.25	Input kW	1.52	3.27	6.45	9.13	16.20	26.70
		Output Torque Nm	375.	805.	1670.	2300.	4220.	6690.
45.	32.22	Input kW	1.22	2.80	5.42	7.26	15.10	22.50
		Output Torque Nm	350.	810.	1550.	2110.	4310.	6400.
50.	29.00	Input kW	0.93	2.56	4.96	6.30	13.70	19.50
		Output Torque Nm	299.	811.	1560.	2010.	4310.	6400.
56.	25.89	Input kW	1.09	2.24	4.82	7.26	11.50	20.30
		Output Torque Nm	386.	805.	1720.	2580.	4220.	7250.
63.	23.02	Input kW	0.93	2.05	4.41	6.30	10.40	17.60
		Output Torque Nm	369.	805.	1720.	2460.	4220.	7250.
71.	20.42	Input kW	0.62	1.24	2.16	5.47	9.16	14.00
		Output Torque Nm	265.	535.	931.	2330.	3950.	6170.
80.	18.13	Input kW	0.52	0.79	1.59	3.70	7.56	11.80
		Output Torque Nm	251.	380.	763.	1810.	3660.	5610.
90.	16.11	Input kW	0.62	1.24	2.16	5.34	7.59	13.10
		Output Torque Nm	328.	665.	1160.	2790.	4220.	7250.
100	14.50	Input kW	0.52	0.79	1.59	3.70	6.77	11.80
		Output Torque Nm	310.	473.	950.	2220.	4220.	7040.

Input mechanical rating exceeds thermal capacity, check thermal power page 108

SERIES F

RATINGS AT 1450 RPM INPUT

9608

TRIPLE REDUCTION

NOMINAL RATIO	NOMINAL OUTPUT SPEED REV / MIN	CAPACITY	SIZES OF UNIT					
			F0430	F0630	F0730	F0830	F0930	F1030
63.	23.02	Input kW	0.94	2.02	3.42	*	*	*
		Output Torque Nm	378.	811.	1370.	*	*	*
71.	20.42	Input kW	0.82	1.77	3.10	*	*	*
		Output Torque Nm	378.	811.	1450.	*	*	*
80.	18.13	Input kW	0.78	1.61	3.42	*	*	*
		Output Torque Nm	386.	806.	1700.	*	*	*
90.	16.11	Input kW	0.68	1.42	2.97	*	*	*
		Output Torque Nm	386.	806.	1720.	*	*	*
100	14.50	Input kW	0.61	1.24	2.48	4.27	6.67	9.81
		Output Torque Nm	378.	811.	1630.	2780.	4310.	6370.
112	12.95	Input kW	0.52	1.14	2.36	3.78	6.00	8.87
		Output Torque Nm	378.	811.	1660.	2780.	4310.	6400.
125	11.60	Input kW	0.50	0.99	2.10	3.50	5.08	8.90
		Output Torque Nm	386.	806.	1720.	2790.	4220.	7250.
140	10.36	Input kW	0.43	0.91	1.97	3.11	4.57	8.01
		Output Torque Nm	386.	806.	1720.	2790.	4220.	7250.
160	9.06	Input kW	0.37	0.79	1.62	2.68	4.26	6.22
		Output Torque Nm	378.	811.	1660.	2780.	4310.	6400.
180	8.06	Input kW	0.34	0.70	1.48	2.44	3.85	5.40
		Output Torque Nm	378.	812.	1660.	2780.	4310.	6400.
200	7.25	Input kW	0.31	0.63	1.35	2.20	3.24	5.62
		Output Torque Nm	386.	806.	1720.	2790.	4230.	7250.
225	6.44	Input kW	0.28	0.56	1.23	2.00	2.93	4.88
		Output Torque Nm	387.	806.	1720.	2790.	4230.	7250.
250	5.80	Input kW	0.23	0.54	1.09	1.83	2.81	4.00
		Output Torque Nm	353.	822.	1660.	2780.	4310.	6400.
280	5.18	Input kW	0.19	0.48	0.79	1.59	2.50	3.73
		Output Torque Nm	342.	834.	1350.	2780.	4310.	6400.
315	4.60	Input kW	0.20	0.43	0.91	1.50	2.14	3.61
		Output Torque Nm	388.	806.	1720.	2790.	4230.	7250.
355	4.08	Input kW	0.18	0.38	0.79	1.30	1.90	3.37
		Output Torque Nm	388.	806.	1680.	2790.	4230.	7250.

* These ratios are not available on sizes F0830, F0930 and F1030

SERIES F

RATINGS AT 1450 RPM INPUT

9608

QUADRUPLE REDUCTION

NOMINAL RATIO	NOMINAL OUTPUT SPEED REV / MIN	CAPACITY	SIZES OF UNIT				
			F0640	F0740	F0840	F0940	F1040
360	4.03	Input kW	0.35	0.76	1.36	1.91	3.26
		Output Torque Nm	749.	1720.	2900.	4220.	7250.
400	3.63	Input kW	0.32	0.71	1.17	1.66	2.81
		Output Torque Nm	806.	1720.	2900.	4220.	7250.
450	3.22	Input kW	0.30	0.62	1.07	1.50	2.64
		Output Torque Nm	806.	1720.	2900.	4220.	7250.
500	2.90	Input kW	0.25	0.55	0.92	1.31	2.27
		Output Torque Nm	806.	1720.	2900.	4220.	7250.
560	2.59	Input kW	0.23	0.49	0.83	1.16	2.04
		Output Torque Nm	806.	1720.	2900.	4220.	7250.
630	2.30	Input kW	0.21	0.43	0.77	1.02	1.804
		Output Torque Nm	806.	1720.	2900.	4220.	7250.
710	2.04	Input kW	0.18	0.40	0.65	0.91	1.64
		Output Torque Nm	806.	1720.	2900.	4220.	7250.
800	1.81	Input kW	0.18	0.34	0.61	0.80	1.46
		Output Torque Nm	850.	1720.	2900.	4220.	7250.
900	1.61	Input kW	0.16	0.31	0.59	0.82	1.35
		Output Torque Nm	850.	1720.	2900.	4220.	7250.
1000	1.45	Input kW	0.14	0.29	0.50	0.71	1.17
		Output Torque Nm	850.	1720.	2900.	4220.	7250.
1100	1.32	Input kW	0.13	0.26	0.46	0.64	1.10
		Output Torque Nm	850.	1720.	2900.	4220.	7250.
1200	1.21	Input kW	0.11	0.22	0.40	0.56	0.94
		Output Torque Nm	850.	1720.	2900.	4220.	7250.
1400	1.04	Input kW	0.10	0.21	0.36	0.49	0.84
		Output Torque Nm	850.	1720.	2900.	4220.	7250.
1600	0.91	Input kW	0.09	0.18	0.33	0.44	0.75
		Output Torque Nm	850.	1720.	2900.	4220.	7250.
1800	0.81	Input kW	0.08	0.16	0.28	0.39	0.68
		Output Torque Nm	850.	1720.	2900.	4220.	7250.
2000	0.73	Input kW	0.07	0.14	0.26	0.34	0.60
		Output Torque Nm	850.	1720.	2900.	4220.	7250.
2200	0.66	Input kW	0.06	0.13	0.23	0.31	0.52
		Output Torque Nm	850.	1720.	2900.	4220.	7250.
2500	0.58	Input kW	0.05	0.12	0.21	0.29	0.48
		Output Torque Nm	850.	1720.	2900.	4220.	7250.
2800	0.52	Input kW	0.05	0.10	0.18	0.25	0.42
		Output Torque Nm	850.	1720.	2900.	4220.	7250.
3200	0.45	Input kW	0.04	0.08	0.15	0.23	0.39
		Output Torque Nm	850.	1720.	2900.	4220.	7250.
3600	0.40	Input kW	0.04	0.08	0.14	0.20	0.34
		Output Torque Nm	850.	1720.	2900.	4220.	7250.
4000	0.36	Input kW	0.03	0.07	0.12	0.19	0.31
		Output Torque Nm	850.	1720.	2900.	4220.	7250.
4500	0.32	Input kW	0.02	0.04	0.11	0.16	0.25
		Output Torque Nm	665.	1160.	2900.	4220.	7250.
5000	0.29	Input kW	0.02	0.04	0.10	0.13	0.23
		Output Torque Nm	665.	1160.	2900.	4220.	7250.
5600	0.26	Input kW	0.02	0.03	0.09	0.12	0.20
		Output Torque Nm	665.	1160.	2900.	4220.	7250.

SERIES F

RATINGS AT 1450 RPM INPUT

9608

QUINTUPLE REDUCTION

NOMINAL RATIO	NOMINAL OUTPUT SPEED REV / MIN	CAPACITY	SIZES OF UNIT				
			F0650	F0750	F0850	F0950	F1050
4500	0.32	Input kW	0.03	0.07	*	*	*
		Output Torque Nm	850.	1720.	*	*	*
5000	0.29	Input kW	0.03	0.06	*	*	*
		Output Torque Nm	850.	1720.	*	*	*
5600	0.26	Input kW	0.03	0.05	*	*	*
		Output Torque Nm	850.	1720.	*	*	*
6300	0.23	Input kW	0.02	0.05	0.07	0.11	0.18
		Output Torque Nm	850.	1720.	2900.	4230.	7250.
7100	0.20	Input kW	0.02	0.04	0.06	0.10	0.17
		Output Torque Nm	850.	1720.	2900.	4220.	7250.
8000	0.18	Input kW	0.02	0.04	0.06	0.09	0.15
		Output Torque Nm	850.	1720.	2900.	4230.	7250.
9000	0.16	Input kW	0.02	0.03	0.05	0.08	0.13
		Output Torque Nm	850.	1720.	2900.	4230.	7250.
10000	0.15	Input kW	0.01	0.03	0.05	0.07	0.12
		Output Torque Nm	850.	1720.	2900.	4230.	7250.
11000	0.13	Input kW	0.01	0.03	0.04	0.06	0.10
		Output Torque Nm	850.	1720.	2900.	4230.	7250.
12000	0.12	Input kW	0.01	0.02	0.04	0.06	0.09
		Output Torque Nm	850.	1720.	2900.	4230.	7250.
14000	0.10	Input kW	0.01	0.02	0.03	0.05	0.08
		Output Torque Nm	850.	1720.	2900.	4230.	7250.
16000	0.09	Input kW	0.01	0.02	0.03	0.04	0.07
		Output Torque Nm	850.	1720.	2900.	4230.	7250.
18000	0.08	Input kW	0.01	0.01	0.03	0.04	0.06
		Output Torque Nm	665.	1160.	2900.	4230.	7250.
20000	0.07	Input kW	0.01	0.01	0.02	0.03	0.06
		Output Torque Nm	665.	1160.	2900.	4230.	7250.

* These ratios are not available on sizes F0850, F0950 and F1050

SERIES F

RATINGS AT 1160 RPM INPUT

9608

DOUBLE REDUCTION

NOMINAL RATIO	NOMINAL OUTPUT SPEED REV / MIN	CAPACITY	SIZES OF UNIT					
			F0420	F0620	F0720	F0820	F0920	F1020
5.0	231.54	Input kW	4.12	10.20	10.30	21.10	51.60	62.60
		Output Torque Nm	168.	412.	423.	856.	2100.	2560.
6.3	183.84	Input kW	4.12	10.20	10.30	21.10	46.30	62.60
		Output Torque Nm	208.	513.	527.	1050.	2430.	3210.
7.1	163.15	Input kW	4.10	9.48	10.30	21.10	44.70	59.80
		Output Torque Nm	235.	539.	588.	1220.	2510.	3420.
8.0	144.82	Input kW	3.92	9.11	10.30	21.10	42.30	57.50
		Output Torque Nm	248.	581.	660.	1350.	2660.	3570.
9.0	128.75	Input kW	3.67	8.14	10.30	21.10	40.00	54.00
		Output Torque Nm	263.	582.	727.	1500.	2820.	3810.
10.	116.00	Input kW	3.56	8.49	10.30	21.10	37.50	51.70
		Output Torque Nm	278.	673.	822.	1660.	3040.	4040.
11.	105.45	Input kW	3.23	7.77	10.30	19.40	35.10	47.00
		Output Torque Nm	295.	706.	950.	1790.	3200.	4320.
12.	96.67	Input kW	3.02	7.26	10.30	18.20	33.00	44.90
		Output Torque Nm	313.	749.	1080.	1880.	3350.	4460.
14.	82.86	Input kW	2.92	6.88	10.20	17.70	30.90	41.90
		Output Torque Nm	328.	778.	1180.	2000.	3620.	4840.
16.	72.50	Input kW	2.72	6.14	9.54	16.60	28.90	40.00
		Output Torque Nm	348.	787.	1240.	2100.	3790.	4990.
18.	64.44	Input kW	2.54	4.25	8.62	14.90	27.40	36.20
		Output Torque Nm	358.	601.	1210.	2130.	3860.	5250.
20.	58.00	Input kW	2.36	4.01	8.14	13.50	25.20	33.60
		Output Torque Nm	377.	659.	1310.	2240.	4050.	5510.
22.	52.73	Input kW	2.13	4.25	8.09	13.70	23.20	32.10
		Output Torque Nm	371.	747.	1410.	2400.	4220.	5850.
25.	46.40	Input kW	1.90	3.94	7.43	12.60	20.40	29.70
		Output Torque Nm	376.	805.	1490.	2560.	4220.	6130.
28.	41.43	Input kW	1.23	3.44	6.62	8.39	19.00	27.70
		Output Torque Nm	282.	798.	1520.	1920.	4310.	6230.
32.	36.25	Input kW	1.21	3.27	5.93	7.30	17.10	25.60
		Output Torque Nm	303.	810.	1540.	1880.	4310.	6400.
36.	32.22	Input kW	1.23	2.79	5.97	8.39	14.40	24.50
		Output Torque Nm	348.	805.	1710.	2350.	4220.	6900.
40.	29.00	Input kW	1.21	2.62	5.32	7.30	13.00	22.80
		Output Torque Nm	375.	805.	1720.	2300.	4220.	7160.
45.	25.78	Input kW	0.98	2.24	4.56	5.81	12.10	18.00
		Output Torque Nm	353.	811.	1630.	2110.	4310.	6400.
50.	23.20	Input kW	0.74	2.05	4.01	5.04	11.00	15.60
		Output Torque Nm	299.	811.	1570.	2010.	4310.	6400.
56.	20.71	Input kW	0.87	1.79	3.86	5.81	9.20	16.20
		Output Torque Nm	386.	806.	1720.	2580.	4220.	7250.
63.	18.41	Input kW	0.74	1.64	3.53	5.04	8.33	14.10
		Output Torque Nm	369.	806.	1720.	2460.	4220.	7250.
71.	16.34	Input kW	0.51	0.99	1.72	4.49	7.32	11.20
		Output Torque Nm	270.	535.	931.	2390.	3950.	6170.
80.	14.50	Input kW	0.42	0.63	1.28	3.04	6.05	9.48
		Output Torque Nm	251.	380.	764.	1860.	3660.	5610.
90.	12.89	Input kW	0.51	0.99	1.72	4.27	6.07	10.50
		Output Torque Nm	334.	665.	1160.	2790.	4220.	7250.
100	11.60	Input kW	0.42	0.63	1.28	3.04	5.42	9.48
		Output Torque Nm	310.	473.	950.	2280.	4220.	7050.

SERIES F

RATINGS AT 1160 RPM INPUT

9608

TRIPLE REDUCTION

NOMINAL RATIO	NOMINAL OUTPUT SPEED REV / MIN	CAPACITY	SIZES OF UNIT					
			F0430	F0630	F0730	F0830	F0930	F1030
63.	18.41	Input kW	0.75	1.61	2.88	*	*	*
		Output Torque Nm	378.	811.	1450.	*	*	*
71.	16.34	Input kW	0.66	1.42	2.62	*	*	*
		Output Torque Nm	378.	811.	1530.	*	*	*
80.	14.50	Input kW	0.62	1.29	2.76	*	*	*
		Output Torque Nm	386.	806.	1720.	*	*	*
90.	12.89	Input kW	0.54	1.13	2.37	*	*	*
		Output Torque Nm	386.	806.	1720.	*	*	*
100	11.60	Input kW	0.49	0.99	2.02	3.41	5.33	7.87
		Output Torque Nm	378.	811.	1660.	2780.	4310.	6400.
112	10.36	Input kW	0.42	0.91	1.89	3.02	4.80	7.09
		Output Torque Nm	378.	811.	1660.	2780.	4310.	6400.
125	9.28	Input kW	0.40	0.79	1.68	2.80	4.06	7.11
		Output Torque Nm	386.	806.	1720.	2790.	4220.	7250.
140	8.29	Input kW	0.35	0.73	1.57	2.48	3.65	6.40
		Output Torque Nm	386.	806.	1720.	2790.	4220.	7250.
160	7.25	Input kW	0.30	0.63	1.29	2.14	3.40	4.97
		Output Torque Nm	378.	812.	1660.	2780.	4310.	6400.
180	6.44	Input kW	0.27	0.57	1.18	1.95	3.08	4.32
		Output Torque Nm	378.	817.	1660.	2780.	4310.	6400.
200	5.80	Input kW	0.25	0.51	1.08	1.76	2.59	4.49
		Output Torque Nm	388.	806.	1720.	2790.	4230.	7250.
225	5.16	Input kW	0.22	0.45	0.99	1.60	2.34	3.90
		Output Torque Nm	388.	806.	1720.	2790.	4230.	7250.
250	4.64	Input kW	0.18	0.44	0.87	1.46	2.24	3.20
		Output Torque Nm	353.	844.	1660.	2780.	4310.	6400.
280	4.14	Input kW	0.16	0.40	0.63	1.27	2.00	2.98
		Output Torque Nm	342.	856.	1350.	2780.	4310.	6400.
315	3.68	Input kW	0.16	0.34	0.72	1.20	1.71	2.89
		Output Torque Nm	388.	806.	1720.	2790.	4230.	7250.
355	3.27	Input kW	0.14	0.30	0.63	1.04	1.52	2.69
		Output Torque Nm	388.	806.	1680.	2790.	4230.	7250.

* These ratios are not available on sizes F0830, F0930 and F1030

SERIES F

RATINGS AT 960 RPM INPUT

9608

DOUBLE REDUCTION

NOMINAL RATIO	NOMINAL OUTPUT SPEED REV / MIN	CAPACITY	SIZES OF UNIT					
			F0420	F0620	F0720	F0820	F0920	F1020
5.0	191.62	Input kW	3.41	8.44	8.53	17.50	45.10	51.80
		Output Torque Nm	168.	412.	424.	857.	2220.	2560.
6.3	152.14	Input kW	3.41	8.44	8.53	17.50	40.50	51.80
		Output Torque Nm	208.	513.	527.	1050.	2570.	3220.
7.1	135.02	Input kW	3.41	7.84	8.53	17.50	39.10	51.80
		Output Torque Nm	236.	539.	588.	1220.	2650.	3580.
8.0	119.85	Input kW	3.41	7.54	8.53	17.50	37.10	50.30
		Output Torque Nm	261.	581.	661.	1350.	2820.	3780.
9.0	106.55	Input kW	3.21	6.74	8.53	17.50	35.00	47.20
		Output Torque Nm	279.	583.	727.	1510.	2990.	4040.
10.	96.00	Input kW	3.11	7.43	8.53	17.50	32.90	45.20
		Output Torque Nm	294.	712.	823.	1660.	3220.	4270.
11.	87.27	Input kW	2.83	6.53	8.53	17.00	30.80	41.10
		Output Torque Nm	312.	718.	950.	1890.	3380.	4580.
12.	80.00	Input kW	2.65	6.23	8.53	15.90	28.90	39.30
		Output Torque Nm	331.	776.	1080.	1990.	3550.	4720.
14.	68.57	Input kW	2.55	5.79	8.53	15.50	27.10	36.70
		Output Torque Nm	348.	792.	1180.	2110.	3840.	5130.
16.	60.00	Input kW	2.37	5.17	8.35	14.50	25.30	35.00
		Output Torque Nm	367.	801.	1320.	2230.	4010.	5290.
18.	53.33	Input kW	2.22	3.52	7.14	12.80	24.00	31.70
		Output Torque Nm	378.	601.	1210.	2220.	4090.	5560.
20.	48.00	Input kW	1.95	3.32	6.74	11.60	22.00	29.40
		Output Torque Nm	378.	659.	1310.	2330.	4280.	5830.
22.	43.64	Input kW	1.80	3.52	7.08	12.00	19.20	28.10
		Output Torque Nm	379.	748.	1490.	2540.	4220.	6190.
25.	38.40	Input kW	1.61	3.26	6.51	10.60	16.90	26.00
		Output Torque Nm	384.	805.	1570.	2610.	4220.	6480.
28.	34.29	Input kW	1.02	2.85	5.70	6.95	15.70	23.50
		Output Torque Nm	282.	798.	1580.	1920.	4310.	6400.
32.	30.00	Input kW	1.01	2.71	5.10	6.04	14.10	21.20
		Output Torque Nm	303.	811.	1600.	1880.	4310.	6400.
36.	26.67	Input kW	1.02	2.31	4.98	6.95	11.90	21.30
		Output Torque Nm	348.	805.	1720.	2350.	4220.	7250.
40.	24.00	Input kW	1.01	2.16	4.40	6.04	10.70	19.10
		Output Torque Nm	375.	805.	1720.	2300.	4220.	7250.
45.	21.33	Input kW	0.81	1.86	3.83	4.81	10.00	14.90
		Output Torque Nm	353.	811.	1660.	2110.	4310.	6400.
50.	19.20	Input kW	0.61	1.70	3.32	4.17	9.07	12.90
		Output Torque Nm	299.	811.	1570.	2010.	4310.	6400.
56.	17.14	Input kW	0.72	1.48	3.19	4.81	7.61	13.40
		Output Torque Nm	386.	806.	1720.	2580.	4220.	7250.
63.	15.24	Input kW	0.61	1.36	2.92	4.17	6.89	11.70
		Output Torque Nm	369.	806.	1720.	2460.	4220.	7250.
71.	13.52	Input kW	0.43	0.82	1.43	3.74	6.06	9.25
		Output Torque Nm	275.	535.	931.	2410.	3950.	6170.
80.	12.00	Input kW	0.34	0.52	1.06	2.58	5.01	7.84
		Output Torque Nm	251.	381.	764.	1910.	3660.	5610.
90.	10.67	Input kW	0.43	0.82	1.43	3.53	5.03	8.66
		Output Torque Nm	340.	665.	1160.	2790.	4220.	7250.
100	9.60	Input kW	0.34	0.52	1.06	2.58	4.48	7.84
		Output Torque Nm	310.	473.	950.	2340.	4220.	7050.

SERIES F

RATINGS AT 960 RPM INPUT

9608

TRIPLE REDUCTION

NOMINAL RATIO	NOMINAL OUTPUT SPEED REV / MIN	CAPACITY	SIZES OF UNIT					
			F0430	F0630	F0730	F0830	F0930	F1030
63.	15.24	Input kW	0.62	1.33	2.49	*	*	*
		Output Torque Nm	378.	811.	1510.	*	*	*
71.	13.52	Input kW	0.54	1.17	2.30	*	*	*
		Output Torque Nm	378.	811.	1620.	*	*	*
80.	12.00	Input kW	0.51	1.07	2.28	*	*	*
		Output Torque Nm	386.	806.	1720.	*	*	*
90.	10.67	Input kW	0.45	0.94	1.96	*	*	*
		Output Torque Nm	386.	806.	1720.	*	*	*
100	9.60	Input kW	0.40	0.82	1.67	2.82	4.41	6.51
		Output Torque Nm	378.	811.	1660.	2780.	4310.	6400.
112	8.57	Input kW	0.35	0.75	1.56	2.50	3.97	5.86
		Output Torque Nm	378.	811.	1660.	2780.	4310.	6400.
125	7.68	Input kW	0.33	0.65	1.39	2.32	3.35	5.88
		Output Torque Nm	386.	806.	1720.	2790.	4220.	7250.
140	6.86	Input kW	0.29	0.60	1.30	2.05	3.02	5.29
		Output Torque Nm	386.	806.	1720.	2790.	4230.	7250.
160	6.00	Input kW	0.25	0.53	1.07	1.77	2.81	4.11
		Output Torque Nm	378.	823.	1660.	2780.	4310.	6400.
180	5.33	Input kW	0.22	0.48	0.98	1.61	2.55	3.57
		Output Torque Nm	378.	835.	1660.	2780.	4310.	6400.
200	4.80	Input kW	0.21	0.42	0.89	1.45	2.14	3.71
		Output Torque Nm	388.	806.	1720.	2790.	4230.	7250.
225	4.27	Input kW	0.19	0.37	0.82	1.32	1.94	3.23
		Output Torque Nm	388.	806.	1720.	2790.	4230.	7250.
250	3.84	Input kW	0.15	0.38	0.72	1.21	1.86	2.65
		Output Torque Nm	353.	862.	1660.	2780.	4310.	6400.
280	3.43	Input kW	0.13	0.34	0.52	1.05	1.65	2.47
		Output Torque Nm	342.	875.	1350.	2780.	4310.	6400.
315	3.05	Input kW	0.13	0.28	0.60	0.99	1.41	2.39
		Output Torque Nm	388.	806.	1720.	2790.	4230.	7250.
355	2.70	Input kW	0.12	0.25	0.52	0.86	1.26	2.23
		Output Torque Nm	388.	806.	1680.	2790.	4230.	7250.

* These ratios are not available on sizes F0830, F0930 and F1030

SERIES F

RATINGS AT 960 RPM INPUT

9608

QUADRUPLE REDUCTION

NOMINAL RATIO	NOMINAL OUTPUT SPEED REV / MIN	CAPACITY	SIZES OF UNIT				
			F0640	F0740	F0840	F0940	F1040
360	2.67	Input kW	0.23	0.50	0.90	1.26	2.15
		Output Torque Nm	749.	1720.	2900.	4220.	7250.
400	2.40	Input kW	0.21	0.47	0.77	1.10	1.85
		Output Torque Nm	806.	1720.	2900.	4220.	7250.
450	2.13	Input kW	0.20	0.41	0.71	0.99	1.74
		Output Torque Nm	806.	1720.	2900.	4220.	7250.
500	1.92	Input kW	0.17	0.37	0.61	0.86	1.49
		Output Torque Nm	806.	1720.	2900.	4220.	7250.
560	1.71	Input kW	0.15	0.32	0.55	0.76	1.34
		Output Torque Nm	806.	1720.	2900.	4220.	7250.
630	1.52	Input kW	0.14	0.28	0.51	0.68	1.19
		Output Torque Nm	806.	1720.	2900.	4220.	7250.
710	1.35	Input kW	0.12	0.26	0.43	0.60	1.08
		Output Torque Nm	806.	1720.	2900.	4220.	7250.
800	1.20	Input kW	0.12	0.22	0.40	0.53	0.96
		Output Torque Nm	850.	1720.	2900.	4220.	7250.
900	1.07	Input kW	0.11	0.21	0.39	0.54	0.89
		Output Torque Nm	850.	1720.	2900.	4220.	7250.
1000	0.96	Input kW	0.09	0.19	0.33	0.47	0.76
		Output Torque Nm	850.	1720.	2900.	4220.	7250.
1100	0.87	Input kW	0.08	0.17	0.31	0.42	0.72
		Output Torque Nm	850.	1720.	2900.	4220.	7250.
1200	0.80	Input kW	0.07	0.15	0.26	0.37	0.62
		Output Torque Nm	850.	1720.	2900.	4220.	7250.
1400	0.69	Input kW	0.07	0.14	0.23	0.33	0.55
		Output Torque Nm	850.	1720.	2900.	4220.	7250.
1600	0.60	Input kW	0.06	0.12	0.22	0.29	0.49
		Output Torque Nm	850.	1720.	2900.	4220.	7250.
1800	0.53	Input kW	0.05	0.11	0.19	0.26	0.45
		Output Torque Nm	850.	1720.	2900.	4220.	7250.
2000	0.48	Input kW	0.05	0.09	0.17	0.26	0.40
		Output Torque Nm	850.	1720.	2900.	4220.	7250.
2200	0.44	Input kW	0.04	0.08	0.15	0.21	0.34
		Output Torque Nm	850.	1720.	2900.	4220.	7250.
2500	0.38	Input kW	0.03	0.08	0.14	0.19	0.31
		Output Torque Nm	850.	1720.	2900.	4220.	7250.
2800	0.34	Input kW	0.03	0.07	0.12	0.16	0.28
		Output Torque Nm	850.	1720.	2900.	4220.	7250.
3200	0.30	Input kW	0.03	0.06	0.10	0.15	0.25
		Output Torque Nm	850.	1720.	2900.	4220.	7250.
3600	0.27	Input kW	0.03	0.05	0.09	0.13	0.22
		Output Torque Nm	850.	1720.	2900.	4220.	7250.
4000	0.24	Input kW	0.02	0.05	0.08	0.12	0.20
		Output Torque Nm	850.	1720.	2900.	4220.	7250.
4500	0.21	Input kW	0.02	0.03	0.07	0.11	0.16
		Output Torque Nm	665.	1160.	2900.	4220.	7250.
5000	0.19	Input kW	0.01	0.03	0.07	0.09	0.15
		Output Torque Nm	665.	1160.	2900.	4220.	7250.
5600	0.17	Input kW	0.01	0.02	0.06	0.08	0.13
		Output Torque Nm	665.	1160.	2900.	4220.	7250.

SERIES F

RATINGS AT 960 RPM INPUT

9608

QUINTUPLE REDUCTION

NOMINAL RATIO	NOMINAL OUTPUT SPEED REV / MIN	CAPACITY	SIZES OF UNIT				
			F0650	F0750	F0850	F0950	F1050
4500	0.21	Input kW	0.02	0.04	*	*	*
		Output Torque Nm	850.	1720.	*	*	*
5000	0.19	Input kW	0.02	0.04	*	*	*
		Output Torque Nm	850.	1720.	*	*	*
5600	0.17	Input kW	0.02	0.03	*	*	*
		Output Torque Nm	850.	1720.	*	*	*
6300	0.15	Input kW	0.02	0.03	0.05	0.07	0.12
		Output Torque Nm	850.	1720.	2900.	4230.	7250.
7100	0.14	Input kW	0.01	0.03	0.04	0.07	0.11
		Output Torque Nm	850.	1720.	2900.	4220.	7250.
8000	0.12	Input kW	0.01	0.02	0.04	0.06	0.10
		Output Torque Nm	850.	1720.	2900.	4230.	7250.
9000	0.11	Input kW	0.01	0.02	0.03	0.05	0.09
		Output Torque Nm	850.	1720.	2900.	4230.	7250.
10000	0.10	Input kW	0.01	0.02	0.03	0.05	0.08
		Output Torque Nm	850.	1720.	2900.	4230.	7250.
11000	0.09	Input kW	0.01	0.02	0.03	0.04	0.07
		Output Torque Nm	850.	1720.	2900.	4230.	7250.
12000	0.08	Input kW	0.01	0.02	0.02	0.04	0.06
		Output Torque Nm	850.	1720.	2900.	4230.	7250.
14000	0.07	Input kW	0.01	0.01	0.02	0.03	0.06
		Output Torque Nm	850.	1720.	2900.	4230.	7250.
16000	0.06	Input kW	0.01	0.01	0.02	0.03	0.05
		Output Torque Nm	850.	1720.	2900.	4230.	7250.
18000	0.05	Input kW	0.004	0.01	0.02	0.03	0.04
		Output Torque Nm	665.	1160.	2900.	4230.	7250.
20000	0.05	Input kW	0.004	0.01	0.02	0.02	0.04
		Output Torque Nm	665.	1160.	2900.	4230.	7250.

* These ratios are not available on sizes F0850, F0950 and F1050

SERIES F

RATINGS AT 725 RPM INPUT

9608

DOUBLE REDUCTION

NOMINAL RATIO	NOMINAL OUTPUT SPEED REV / MIN	CAPACITY	SIZES OF UNIT					
			F0420	F0620	F0720	F0820	F0920	F1020
5.0	144.71	Input kW	2.58	6.38	6.44	13.20	37.00	39.10
		Output Torque Nm	168.	413.	424.	858.	2420.	2560.
6.3	114.90	Input kW	2.58	6.38	6.44	13.20	33.20	39.10
		Output Torque Nm	208.	513.	528.	1050.	2800.	3220.
7.1	101.97	Input kW	2.58	5.92	6.44	13.20	32.10	39.10
		Output Torque Nm	237.	539.	589.	1220.	2890.	3580.
8.0	90.51	Input kW	2.58	5.69	6.44	13.20	30.40	39.10
		Output Torque Nm	261.	581.	661.	1350.	3070.	3900.
9.0	80.47	Input kW	2.58	5.09	6.44	13.20	28.70	38.80
		Output Torque Nm	296.	583.	728.	1510.	3250.	4390.
10.	72.50	Input kW	2.56	5.69	6.44	13.20	27.00	37.10
		Output Torque Nm	320.	723.	823.	1660.	3500.	4650.
11.	65.91	Input kW	2.32	4.93	6.44	13.20	25.30	33.80
		Output Torque Nm	339.	718.	951.	1950.	3680.	4980.
12.	60.42	Input kW	2.17	4.70	6.44	12.70	23.60	32.30
		Output Torque Nm	361.	776.	1080.	2110.	3850.	5140.
14.	51.79	Input kW	2.07	4.44	6.44	12.70	22.20	30.10
		Output Torque Nm	373.	804.	1180.	2300.	4170.	5580.
16.	45.31	Input kW	1.84	3.92	6.44	11.90	20.10	28.80
		Output Torque Nm	378.	805.	1350.	2420.	4220.	5750.
18.	40.28	Input kW	1.68	2.66	5.39	10.10	19.10	26.10
		Output Torque Nm	378.	601.	1210.	2310.	4310.	6050.
20.	36.25	Input kW	1.48	2.51	5.09	9.14	16.80	24.10
		Output Torque Nm	378.	659.	1310.	2440.	4310.	6340.
22.	32.95	Input kW	1.38	2.66	5.39	9.43	14.50	23.10
		Output Torque Nm	386.	748.	1500.	2640.	4220.	6740.
25.	29.00	Input kW	1.22	2.46	5.09	8.22	12.70	21.40
		Output Torque Nm	386.	805.	1630.	2680.	4220.	7050.
28.	25.89	Input kW	0.77	2.15	4.33	5.25	11.80	17.80
		Output Torque Nm	282.	798.	1590.	1920.	4310.	6400.
32.	22.66	Input kW	0.76	2.05	3.99	4.56	10.70	16.00
		Output Torque Nm	303.	811.	1660.	1880.	4310.	6400.
36.	20.14	Input kW	0.77	1.74	3.76	5.25	9.00	16.00
		Output Torque Nm	349.	806.	1720.	2350.	4220.	7250.
40.	18.13	Input kW	0.76	1.63	3.33	4.56	8.10	14.50
		Output Torque Nm	375.	806.	1720.	2300.	4220.	7250.
45.	16.11	Input kW	0.62	1.40	2.90	3.63	7.57	11.20
		Output Torque Nm	353.	811.	1660.	2110.	4310.	6400.
50.	14.50	Input kW	0.46	1.28	2.51	3.15	6.85	9.77
		Output Torque Nm	299.	811.	1570.	2010.	4310.	6400.
56.	12.95	Input kW	0.54	1.12	2.41	3.63	5.75	10.10
		Output Torque Nm	386.	806.	1720.	2580.	4220.	7250.
63.	11.51	Input kW	0.46	1.02	2.20	3.15	5.21	8.82
		Output Torque Nm	369.	806.	1720.	2460.	4220.	7250.
71.	10.21	Input kW	0.33	0.62	1.08	2.82	4.58	6.98
		Output Torque Nm	282.	535.	931.	2410.	3950.	6170.
80.	9.06	Input kW	0.26	0.40	0.80	2.02	3.78	5.92
		Output Torque Nm	251.	381.	764.	1980.	3660.	5610.
90.	8.06	Input kW	0.33	0.62	1.08	2.67	3.80	6.54
		Output Torque Nm	349.	665.	1160.	2790.	4220.	7250.
100	7.25	Input kW	0.26	0.40	0.80	2.02	3.38	5.92
		Output Torque Nm	310.	473.	951.	2420.	4220.	7050.

SERIES F

RATINGS AT 725 RPM INPUT

9608

TRIPLE REDUCTION

NOMINAL RATIO	NOMINAL OUTPUT SPEED REV / MIN	CAPACITY	SIZES OF UNIT					
			F0430	F0630	F0730	F0830	F0930	F1030
63.	11.51	Input kW	0.47	1.01	2.07	*	*	*
		Output Torque Nm	378.	811.	1660.	*	*	*
71.	10.21	Input kW	0.41	0.89	1.78	*	*	*
		Output Torque Nm	378.	811.	1660.	*	*	*
80.	9.06	Input kW	0.39	0.81	1.72	*	*	*
		Output Torque Nm	386.	806.	1720.	*	*	*
90.	8.06	Input kW	0.34	0.71	1.48	*	*	*
		Output Torque Nm	386.	806.	1720.	*	*	*
100	7.25	Input kW	0.31	0.62	1.26	2.13	3.32	4.91
		Output Torque Nm	378.	812.	1660.	2780.	4310.	6400.
112	6.47	Input kW	0.26	0.57	1.18	1.89	2.99	4.42
		Output Torque Nm	378.	815.	1660.	2780.	4310.	6400.
125	5.80	Input kW	0.25	0.49	1.05	1.75	2.53	4.44
		Output Torque Nm	388.	806.	1720.	2790.	4230.	7250.
140	5.18	Input kW	0.22	0.45	0.98	1.55	2.28	3.99
		Output Torque Nm	388.	806.	1720.	2790.	4230.	7250.
160	4.53	Input kW	0.19	0.42	0.81	1.34	2.12	3.10
		Output Torque Nm	378.	851.	1660.	2780.	4310.	6400.
180	4.03	Input kW	0.17	0.37	0.74	1.22	1.92	2.70
		Output Torque Nm	378.	863.	1660.	2780.	4310.	6400.
200	3.63	Input kW	0.16	0.32	0.67	1.10	1.62	2.80
		Output Torque Nm	388.	806.	1720.	2790.	4230.	7250.
225	3.22	Input kW	0.14	0.28	0.62	1.00	1.46	2.43
		Output Torque Nm	388.	806.	1720.	2790.	4230.	7250.
250	2.90	Input kW	0.11	0.29	0.54	0.91	1.40	2.00
		Output Torque Nm	353.	891.	1660.	2780.	4310.	6400.
280	2.59	Input kW	0.10	0.26	0.40	0.79	1.25	1.86
		Output Torque Nm	342.	892.	1350.	2780.	4310.	6400.
315	2.30	Input kW	0.10	0.21	0.45	0.75	1.07	1.80
		Output Torque Nm	388.	806.	1720.	2790.	4230.	7250.
355	2.04	Input kW	0.09	0.19	0.40	0.65	0.95	1.68
		Output Torque Nm	388.	806.	1680.	2790.	4230.	7250.

* These ratios are not available on sizes F0830, F0930 and F1030

SERIES F

RATINGS AT 480 RPM INPUT

9608

DOUBLE REDUCTION

NOMINAL RATIO	NOMINAL OUTPUT SPEED REV / MIN	CAPACITY	SIZES OF UNIT					
			F0420	F0620	F0720	F0820	F0920	F1020
5.0	95.81	Input kW	1.71	4.22	4.26	8.73	25.90	25.90
		Output Torque Nm	169.	413.	425.	859.	2550.	2560.
6.3	76.07	Input kW	1.71	4.22	4.26	8.73	24.90	25.90
		Output Torque Nm	208.	514.	529.	1050.	3160.	3220.
7.1	67.51	Input kW	1.71	3.92	4.26	8.73	23.60	25.90
		Output Torque Nm	237.	540.	589.	1220.	3210.	3590.
8.0	59.93	Input kW	1.71	3.77	4.26	8.73	22.30	25.90
		Output Torque Nm	261.	582.	662.	1350.	3400.	3900.
9.0	53.27	Input kW	1.71	3.37	4.26	8.73	21.00	25.90
		Output Torque Nm	296.	583.	728.	1510.	3580.	4430.
10.	48.00	Input kW	1.71	3.77	4.26	8.73	20.20	25.90
		Output Torque Nm	322.	724.	824.	1660.	3970.	4900.
11.	43.64	Input kW	1.71	3.27	4.26	8.73	18.30	25.30
		Output Torque Nm	376.	719.	951.	1950.	4030.	5630.
12.	40.00	Input kW	1.51	3.11	4.26	8.73	16.90	24.20
		Output Torque Nm	378.	776.	1080.	2190.	4150.	5820.
14.	34.29	Input kW	1.41	2.94	4.26	8.73	14.90	22.60
		Output Torque Nm	386.	805.	1180.	2390.	4220.	6310.
16.	30.00	Input kW	1.25	2.60	4.26	8.69	13.30	21.50
		Output Torque Nm	386.	805.	1350.	2670.	4220.	6510.
18.	26.67	Input kW	1.11	1.76	3.57	7.28	12.60	18.20
		Output Torque Nm	378.	602.	1210.	2520.	4310.	6400.
20.	24.00	Input kW	0.98	1.66	3.37	6.58	11.10	16.10
		Output Torque Nm	378.	660.	1310.	2650.	4310.	6400.
22.	21.82	Input kW	0.92	1.76	3.57	6.49	9.60	16.50
		Output Torque Nm	386.	748.	1500.	2750.	4220.	7250.
25.	19.20	Input kW	0.81	1.63	3.37	5.65	8.43	14.50
		Output Torque Nm	386.	806.	1630.	2790.	4220.	7250.
28.	17.14	Input kW	0.51	1.42	2.87	3.47	7.84	11.80
		Output Torque Nm	282.	798.	1590.	1920.	4310.	6400.
32.	15.00	Input kW	0.50	1.35	2.64	3.02	7.06	10.60
		Output Torque Nm	303.	811.	1660.	1880.	4310.	6400.
36.	13.33	Input kW	0.51	1.16	2.49	3.47	5.95	10.60
		Output Torque Nm	349.	806.	1720.	2350.	4220.	7250.
40.	12.00	Input kW	0.50	1.08	2.20	3.02	5.36	9.56
		Output Torque Nm	375.	806.	1720.	2300.	4220.	7250.
45.	10.67	Input kW	0.41	0.93	1.92	2.40	5.01	7.44
		Output Torque Nm	353.	811.	1660.	2110.	4310.	6400.
50.	9.60	Input kW	0.31	0.85	1.66	2.09	4.53	6.46
		Output Torque Nm	299.	811.	1570.	2010.	4310.	6400.
56.	8.57	Input kW	0.36	0.74	1.60	2.40	3.81	6.72
		Output Torque Nm	386.	806.	1720.	2580.	4220.	7250.
63.	7.62	Input kW	0.31	0.68	1.46	2.09	3.45	5.83
		Output Torque Nm	370.	806.	1720.	2460.	4220.	7250.
71.	6.76	Input kW	0.23	0.41	0.71	1.87	3.03	4.62
		Output Torque Nm	293.	535.	932.	2410.	3950.	6170.
80.	6.00	Input kW	0.17	0.26	0.53	1.42	2.50	3.92
		Output Torque Nm	251.	381.	764.	2100.	3660.	5610.
90.	5.33	Input kW	0.23	0.41	0.71	1.77	2.51	4.33
		Output Torque Nm	362.	665.	1160.	2790.	4230.	7250.
100	4.80	Input kW	0.17	0.26	0.53	1.42	2.24	3.92
		Output Torque Nm	310.	474.	951.	2570.	4230.	7050.

SERIES F

RATINGS AT 480 RPM INPUT

9608

TRIPLE REDUCTION

NOMINAL RATIO	NOMINAL OUTPUT SPEED REV / MIN	CAPACITY	SIZES OF UNIT					
			F0430	F0630	F0730	F0830	F0930	F1030
63.	7.62	Input kW	0.31	0.67	1.37	*	*	*
		Output Torque Nm	378.	812.	1660.	*	*	*
71.	6.76	Input kW	0.27	0.59	1.18	*	*	*
		Output Torque Nm	378.	812.	1660.	*	*	*
80.	6.00	Input kW	0.26	0.53	1.14	*	*	*
		Output Torque Nm	388.	806.	1720.	*	*	*
90.	5.33	Input kW	0.23	0.47	0.98	*	*	*
		Output Torque Nm	388.	806.	1720.	*	*	*
100	4.80	Input kW	0.20	0.43	0.83	1.41	2.20	3.25
		Output Torque Nm	378.	847.	1660.	2780.	4310.	6400.
112	4.29	Input kW	0.17	0.40	0.78	1.25	1.98	2.93
		Output Torque Nm	378.	856.	1660.	2780.	4310.	6400.
125	3.84	Input kW	0.17	0.33	0.69	1.15	1.67	2.93
		Output Torque Nm	388.	806.	1720.	2790.	4230.	7250.
140	3.43	Input kW	0.14	0.30	0.65	1.02	1.51	2.64
		Output Torque Nm	388.	806.	1720.	2790.	4230.	7250.
160	3.00	Input kW	0.12	0.29	0.54	0.89	1.40	2.05
		Output Torque Nm	378.	892.	1660.	2780.	4310.	6400.
180	2.67	Input kW	0.11	0.26	0.49	0.81	1.27	1.78
		Output Torque Nm	378.	892.	1660.	2780.	4310.	6400.
200	2.40	Input kW	0.10	0.21	0.45	0.73	1.07	1.85
		Output Torque Nm	388.	806.	1720.	2790.	4230.	7250.
225	2.13	Input kW	0.09	0.19	0.41	0.66	0.97	1.61
		Output Torque Nm	388.	806.	1720.	2790.	4230.	7250.
250	1.92	Input kW	0.08	0.19	0.36	0.60	0.93	1.32
		Output Torque Nm	353.	892.	1660.	2780.	4310.	6400.
280	1.71	Input kW	0.06	0.17	0.26	0.53	0.83	1.23
		Output Torque Nm	342.	892.	1350.	2780.	4310.	6400.
315	1.52	Input kW	0.07	0.14	0.30	0.49	0.71	1.19
		Output Torque Nm	388.	806.	1720.	2790.	4230.	7250.
355	1.35	Input kW	0.06	0.12	0.26	0.43	0.63	1.11
		Output Torque Nm	388.	806.	1680.	2790.	4230.	7250.

* These ratios are not available on sizes F0830, F0930 and F1030

SERIES F

RATINGS AT 250 RPM INPUT

9608

DOUBLE REDUCTION

NOMINAL RATIO	NOMINAL OUTPUT SPEED REV / MIN	CAPACITY	SIZES OF UNIT					
			F0420	F0620	F0720	F0820	F0920	F1020
5.0	49.90	Input kW	0.89	2.20	2.22	4.55	13.50	13.50
		Output Torque Nm	169.	414.	425.	860.	2560.	2570.
6.3	39.62	Input kW	0.89	2.20	2.22	4.55	13.50	13.50
		Output Torque Nm	209.	514.	530.	1050.	3300.	3230.
7.1	35.16	Input kW	0.89	2.04	2.22	4.55	13.50	13.50
		Output Torque Nm	237.	540.	590.	1220.	3520.	3590.
8.0	31.21	Input kW	0.89	1.96	2.22	4.55	13.30	13.50
		Output Torque Nm	261.	582.	663.	1360.	3900.	3900.
9.0	27.75	Input kW	0.89	1.75	2.22	4.55	12.50	13.50
		Output Torque Nm	296.	584.	729.	1510.	4110.	4430.
10.	25.00	Input kW	0.89	1.96	2.22	4.55	11.20	13.50
		Output Torque Nm	323.	724.	825.	1660.	4220.	4900.
11.	22.73	Input kW	0.89	1.70	2.22	4.55	10.20	13.50
		Output Torque Nm	376.	719.	952.	1950.	4310.	5770.
12.	20.83	Input kW	0.79	1.62	2.22	4.55	9.12	13.50
		Output Torque Nm	378.	776.	1080.	2190.	4310.	6230.
14.	17.86	Input kW	0.74	1.53	2.22	4.55	7.74	13.50
		Output Torque Nm	386.	806.	1180.	2390.	4220.	7250.
16.	15.63	Input kW	0.65	1.35	2.22	4.55	6.93	12.50
		Output Torque Nm	386.	806.	1350.	2680.	4220.	7250.
18.	13.89	Input kW	0.58	0.92	1.86	4.02	6.58	9.49
		Output Torque Nm	378.	602.	1210.	2670.	4310.	6400.
20.	12.50	Input kW	0.51	0.86	1.75	3.57	5.77	8.39
		Output Torque Nm	378.	660.	1310.	2760.	4310.	6400.
22.	11.36	Input kW	0.48	0.92	1.86	3.42	5.00	8.56
		Output Torque Nm	386.	749.	1500.	2790.	4220.	7250.
25.	10.00	Input kW	0.42	0.85	1.75	2.94	4.39	7.57
		Output Torque Nm	386.	806.	1630.	2790.	4220.	7250.
28.	8.93	Input kW	0.26	0.74	1.49	1.81	4.08	6.13
		Output Torque Nm	282.	798.	1590.	1920.	4310.	6400.
32.	7.81	Input kW	0.26	0.71	1.38	1.57	3.67	5.52
		Output Torque Nm	304.	812.	1660.	1880.	4310.	6400.
36.	6.94	Input kW	0.26	0.60	1.29	1.81	3.10	5.53
		Output Torque Nm	349.	806.	1720.	2350.	4230.	7250.
40.	6.25	Input kW	0.26	0.56	1.15	1.57	2.79	4.98
		Output Torque Nm	375.	806.	1720.	2310.	4230.	7250.
45.	5.56	Input kW	0.21	0.49	1.00	1.25	2.61	3.87
		Output Torque Nm	353.	830.	1660.	2110.	4310.	6400.
50.	5.00	Input kW	0.16	0.46	0.86	1.09	2.36	3.37
		Output Torque Nm	299.	838.	1570.	2010.	4310.	6400.
56.	4.46	Input kW	0.19	0.39	0.83	1.25	1.98	3.50
		Output Torque Nm	388.	806.	1720.	2590.	4230.	7250.
63.	3.97	Input kW	0.16	0.35	0.76	1.09	1.79	3.04
		Output Torque Nm	370.	806.	1720.	2460.	4230.	7250.
71.	3.52	Input kW	0.13	0.21	0.37	0.97	1.58	2.41
		Output Torque Nm	312.	535.	932.	2410.	3950.	6170.
80.	3.13	Input kW	0.09	0.14	0.28	0.76	1.30	2.04
		Output Torque Nm	251.	381.	764.	2150.	3660.	5610.
90.	2.78	Input kW	0.13	0.21	0.37	0.92	1.31	2.25
		Output Torque Nm	386.	666.	1160.	2790.	4230.	7250.
100	2.50	Input kW	0.09	0.14	0.28	0.76	1.17	2.04
		Output Torque Nm	310.	474.	951.	2630.	4230.	7050.

SERIES F

RATINGS AT 250 RPM INPUT

9608

TRIPLE REDUCTION

NOMINAL RATIO	NOMINAL OUTPUT SPEED REV / MIN	CAPACITY	SIZES OF UNIT					
			F0430	F0630	F0730	F0830	F0930	F1030
63.	3.97	Input kW	0.16	0.37	0.71	*	*	*
		Output Torque Nm	378.	863.	1660.	*	*	*
71.	3.52	Input kW	0.14	0.33	0.61	*	*	*
		Output Torque Nm	378.	876.	1660.	*	*	*
80.	3.13	Input kW	0.13	0.28	0.59	*	*	*
		Output Torque Nm	388.	806.	1720.	*	*	*
90.	2.78	Input kW	0.12	0.24	0.51	*	*	*
		Output Torque Nm	388.	806.	1720.	*	*	*
100	2.50	Input kW	0.11	0.23	0.43	0.73	1.14	1.69
		Output Torque Nm	378.	892.	1660.	2780.	4310.	6400.
112	2.23	Input kW	0.09	0.22	0.41	0.65	1.03	1.52
		Output Torque Nm	378.	892.	1660.	2780.	4310.	6400.
125	2.00	Input kW	0.09	0.17	0.36	0.60	0.87	1.53
		Output Torque Nm	388.	806.	1720.	2790.	4230.	7250.
140	1.79	Input kW	0.07	0.16	0.34	0.53	0.78	1.37
		Output Torque Nm	388.	806.	1720.	2790.	4230.	7250.
160	1.56	Input kW	0.06	0.15	0.28	0.46	0.73	1.07
		Output Torque Nm	378.	892.	1660.	2780.	4310.	6400.
180	1.39	Input kW	0.06	0.13	0.26	0.42	0.66	0.93
		Output Torque Nm	378.	892.	1660.	2780.	4310.	6400.
200	1.25	Input kW	0.05	0.11	0.23	0.38	0.56	0.96
		Output Torque Nm	388.	806.	1720.	2790.	4230.	7250.
225	1.11	Input kW	0.05	0.10	0.21	0.34	0.50	0.84
		Output Torque Nm	388.	806.	1720.	2790.	4230.	7250.
250	1.00	Input kW	0.04	0.10	0.19	0.31	0.48	0.69
		Output Torque Nm	353.	894.	1660.	2780.	4310.	6400.
280	0.89	Input kW	0.03	0.09	0.14	0.27	0.43	0.64
		Output Torque Nm	342.	898.	1350.	2780.	4310.	6400.
315	0.79	Input kW	0.04	0.07	0.16	0.26	0.37	0.62
		Output Torque Nm	390.	808.	1720.	2790.	4230.	7250.
355	0.70	Input kW	0.03	0.07	0.14	0.22	0.33	0.58
		Output Torque Nm	396.	820.	1680.	2790.	4230.	7250.

* These ratios are not available on sizes F0830, F0930 and F1030

SERIES F

DIMENSIONS

DOUBLE REDUCTION

9610

F		2	0			W	R
---	--	---	---	--	--	---	---

STANDARD UNIT

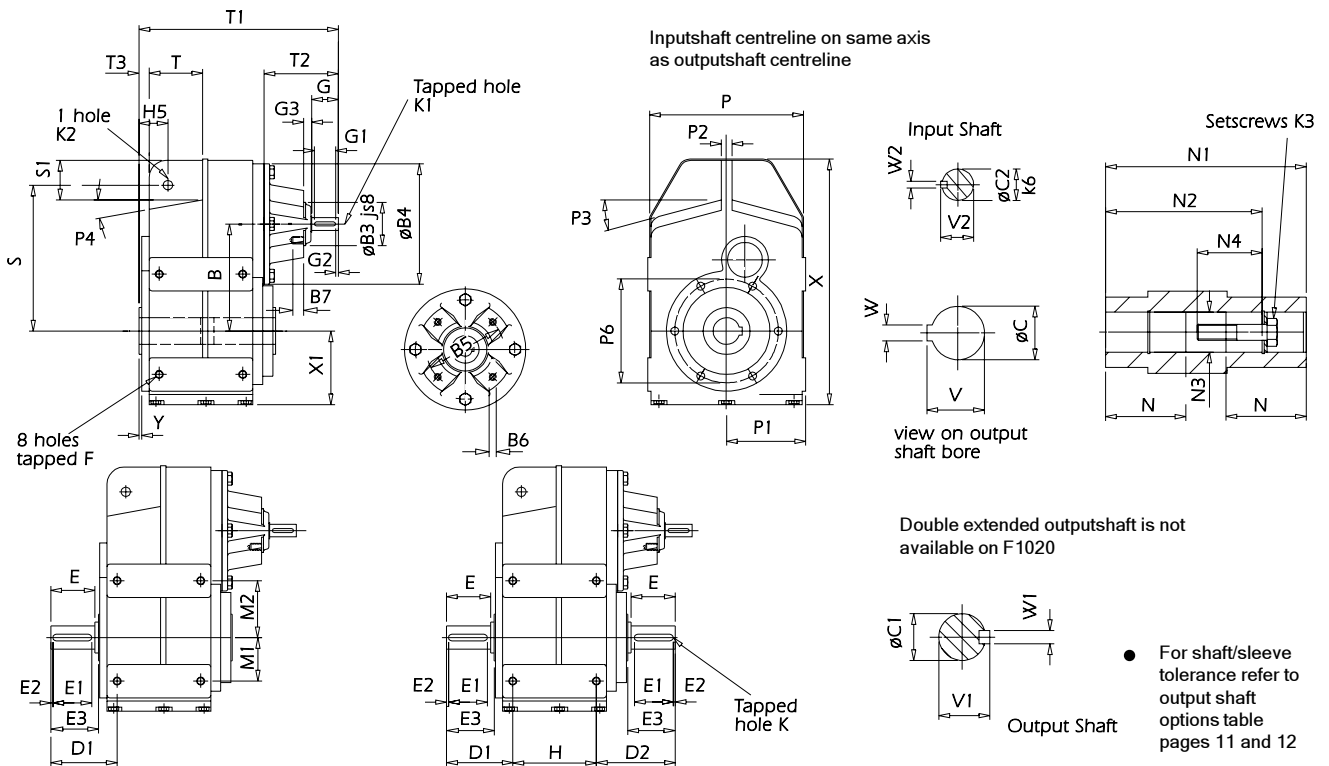

SIZE	B	$\phi B3$	$\phi B4$	$\phi B5$	B6	B7	ϕC	$\phi C1$	$\phi C2$	D1	D2	E	E1	E2	E3	F	G	G1	G2
F0420	120	65	140	90	4 x M8	16	30	30	16	85	97	57	50	3	61	M10x1.5x17	40	32	4
F0620	160	78	180	115	4 x M10	17	40	35	19	99	118	66	58	3	71	M12x1.75x20	40	32	4
F0720	200	98	212	145	4 x M12	20	50	50	24	121	146	86	80	3	91	M16x2x25	50	40	5
F0820	226	98	250	145	4 x M12	20	60	60	28	155	180	114	100	3	120	M16x2x24	60	50	5
F0920	274	125	300	175	4 x M16	30	70	70	38	179	218	135	110	3	141	M16x2Px24	80	70	5
F1020	332	155	360	210	4 x M20	36	80	90	42	213.5	-	172	140	5	172	M20x2Px27	110	70	10

SIZE	G3	H	H5	K	K1	$\phi K2$	K3	M1	M2	N	N1	N2	N3	N4	P
F0420	12	90	32	M10x1.5x22	M5x0.8x12.5	14	M10x50L	50	60	67.5	150	122	30.2	42	166
F0620	22	125	41	M16x2x36	M6x1x16	14	M16x70L	65	85	90	200	156	40.2	60	226
F0720	23	150	50	M16x2x36	M8x1.25x19	22	M16x70L	85	115	105	235	183	50.2	60	266
F0820	23	170	62	M20x2.5x42	M10x1.5x22	22	M20x80L	100	100	117.5	265	210	60.2	66	320
F0920	23	215	70	M20x2.5Px42	M12x1.75Px28	27	M20x80L	125	225	147.5	330	270	70.2	66	384
F1020	34	250	88	M20x2.5Px42	M16x2.0x36	27	M20x80L	158	272	165	370	313	80.2	66	454

SIZE	P1	P2	P3	P4	P6	S	S1	T	T1	T2	T3	V	V1	V2	W	W1	W2	X	X1	Y
F0420	88	12	11°	10°	4 holes, M8x1.25x14, 130 pcd	170	50	55	248	111	13	33.5	33	18	8	8	5	282	85	3
F0620	118	16	15°	10°	6 holes, M12x1.75x20, 150 pcd	218	59	80	296	111	13	43.5	38	21.5	12	10	6	367	110	2
F0720	140	20	20°	11°	6 holes, M12x1.75x20, 150 pcd	278	68	95	335	115	13	54	53.5	27	14	14	8	449	134	2
F0820	170	26	20°	11°	8 holes, M12x1.75x20, 195 pcd	346	79	105	408	160	15	64.5	64	31	18	18	8	526	148	3
F0920	200	30	20°	11°	6 holes, M16x2Px27, 230 pcd	395	100	131	491	195	19	75	74.5	41	20	20	10	612	175	5
F1020	235	36	17°	10°	10 holes, M16x2Px27, 280 pcd	485	136	152	575.5	233	19.5	85	95	45	22	25	12	748	216	5.5

SERIES F

DIMENSIONS

TRIPLE REDUCTION SIZES F04, F06 & F07

0011

F	0	3	0			W	R
---	---	---	---	--	--	---	---

STANDARD UNIT TRIPLE REDUCTION

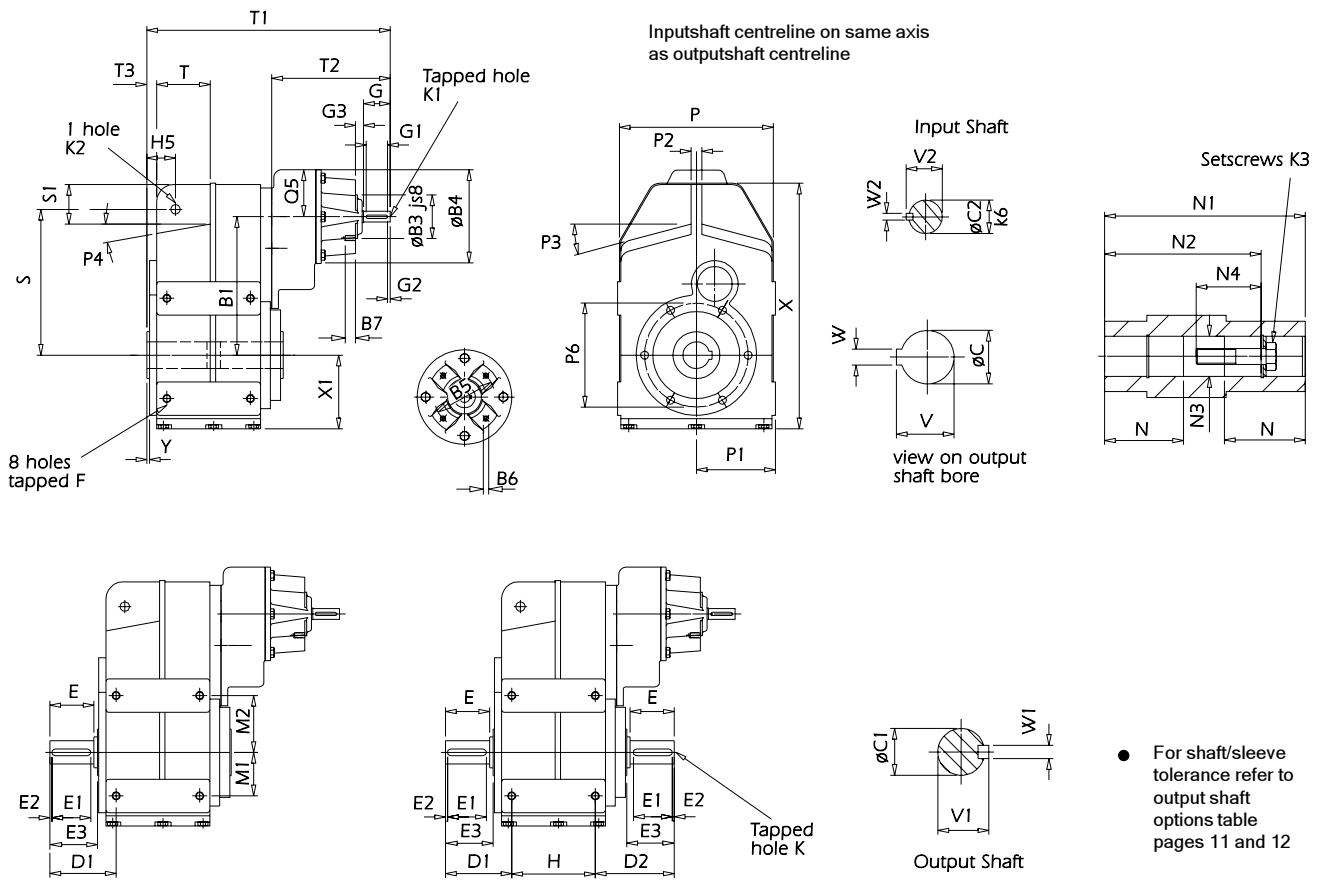

SIZE	B1	øB3	øB4	øB5	B6	B7	øC	øC1	øC2	D1	D2	E	E1	E2	E3	F	G	G1	G2	G3
F0430	156	65 js8	140	90	4 x M8	16	30	30	16	85	97	57	50	3	61	M10x1.5x17	40	32	4	12
F0630	207	65 js8	140	90	4 x M8	16	40	35	16	99	118	66	58	3	71	M12x1.75x20	40	32	4	12
F0730	260	78 js8	180	115	4 x M10	17	50	50	19	121	146	86	80	3	91	M16x2x25	40	32	4	23

SIZE	H	H5	K	K1	øK2	K3	M1	M2	N	N1	N2	N3	N4	P	P1
F0430	90	32	M10x1.5x22	M5x0.8x12.5	14	M10x50L	50	60	67.5	150	122	30.2	42	166	88
F0630	125	41	M16x2x36	M6x1x16	14	M16x70L	65	85	90	200	156	40.2	60	226	118
F0730	150	50	M16x2x36	M8x1.25x19	22	M16x70L	85	115	105	235	183	50.2	60	266	140

SIZE	P2	P3	P4	P6	Q5	S	S1	T	T1	T2	T3	V	V1	V2	W	W1	W2	X	X1	Y
F0430	12	11°	10°	4 holes, M8x1.25x14, 130 pcd	70	170	50	55	304	167	13	33.5	33	18	8	8	5	282	85	3
F0630	16	15°	10°	6 holes, M12x1.75x20, 150 pcd	70	218	59	80	362	177	13	43.5	38	18	12	10	5	367	110	2
F0730	20	20°	11°	6 holes, M12x1.75x20, 150 pcd	90	278	68	95	417	197	13	54	53.5	21.5	14	14	6	449	134	2

SERIES F

DIMENSIONS

TRIPLE REDUCTION SIZES F08, F09 & F10

9610

F			3	0					W	R
---	--	--	---	---	--	--	--	--	---	---

STANDARD UNIT

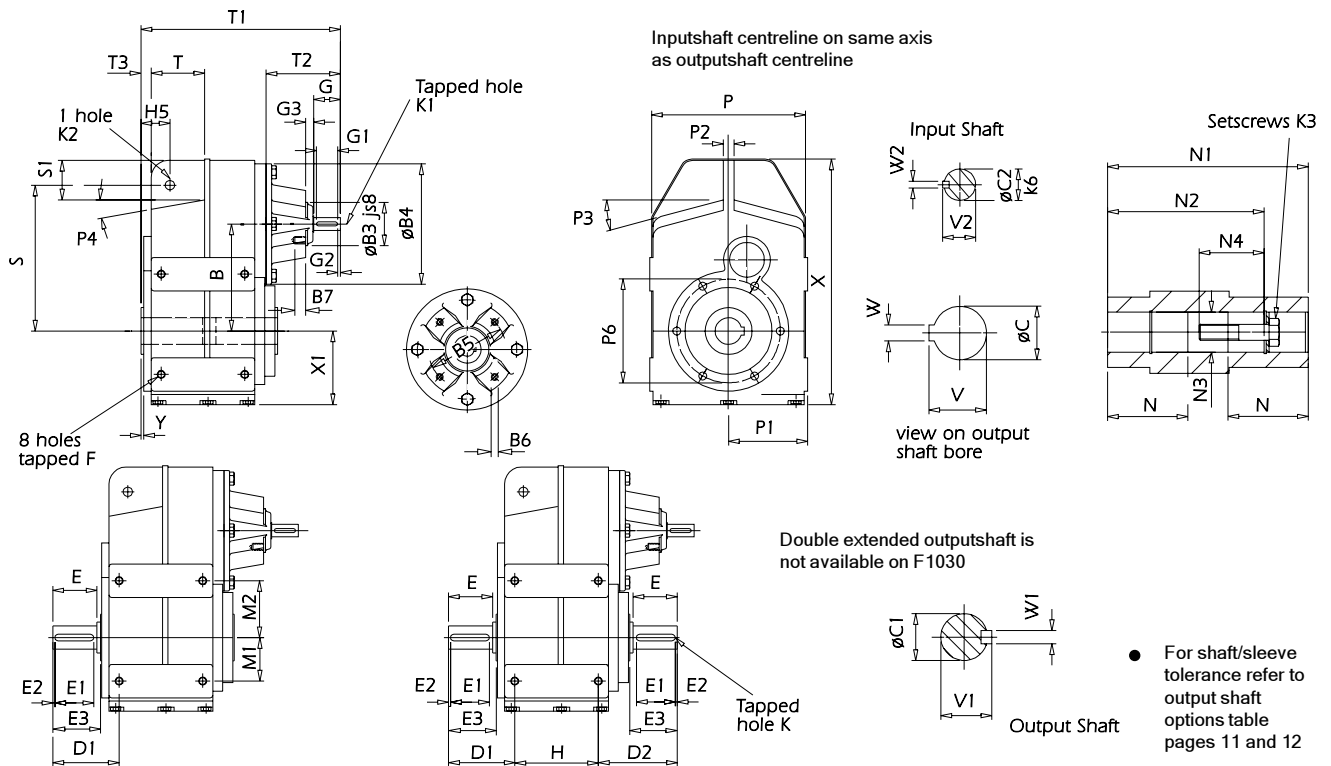

SIZE	B	øB3	øB4	øB5	B6	B7	øC	øC1	øC2	D1	D2	E	E1	E2	E3	F	G	G1	G2
F0830	226	98	212	145	4 x M12	20	60	60	24	155	180	114	100	3	120	M16x2x24	50	40	5
F0930	274	98	250	145	4 x M12	20	70	70	28	179	218	135	110	3	141	M16x2Px24	60	50	5
F1030	332	125	300	175	4 x M16	30	80	90	38	213.5	-	172	140	5	172	M20x2Px27	80	70	5

SIZE	G3	H	H5	K	K1	øK2	K3	M1	M2	N	N1	N2	N3	N4	P
F0830	23	170	62	M20x2.5x42	M8x1.25x19	22	M20x80L	100	100	117.5	265	210	60.2	66	320
F0930	23	215	70	M20x2.5Px42	M10x1.5Px22	27	M20x80L	125	225	147.5	330	270	70.2	66	384
F1030	23	250	88	M20x2.5Px42	M12x1.75Px28	27	M20x80L	158	272	165	370	313	80.2	66	454

SIZE	P1	P2	P3	P4	P6	S	S1	T	T1	T2	T3	V	V1	V2	W	W1	W2	X	X1	Y
F0830	170	26	20°	11°	8 holes, M12x1.75x20, 195 pcd	346	79	105	393	145	15	64.5	64	31	18	18	8	526	148	3
F0930	200	30	20°	11°	6 holes, M16x2Px27, 230 pcd	395	100	131	493	197	19	75	74.5	31	20	20	8	612	175	5
F1030	235	36	17°	10°	10 holes, M16x2Px27, 280 pcd	485	136	152	577.5	235	19.5	85	95	41	22	25	10	748	216	5.5

SERIES F

DIMENSIONS

QUADRUPLE REDUCTION

9610

F			4	0			W	R
---	--	--	---	---	--	--	---	---

STANDARD UNIT

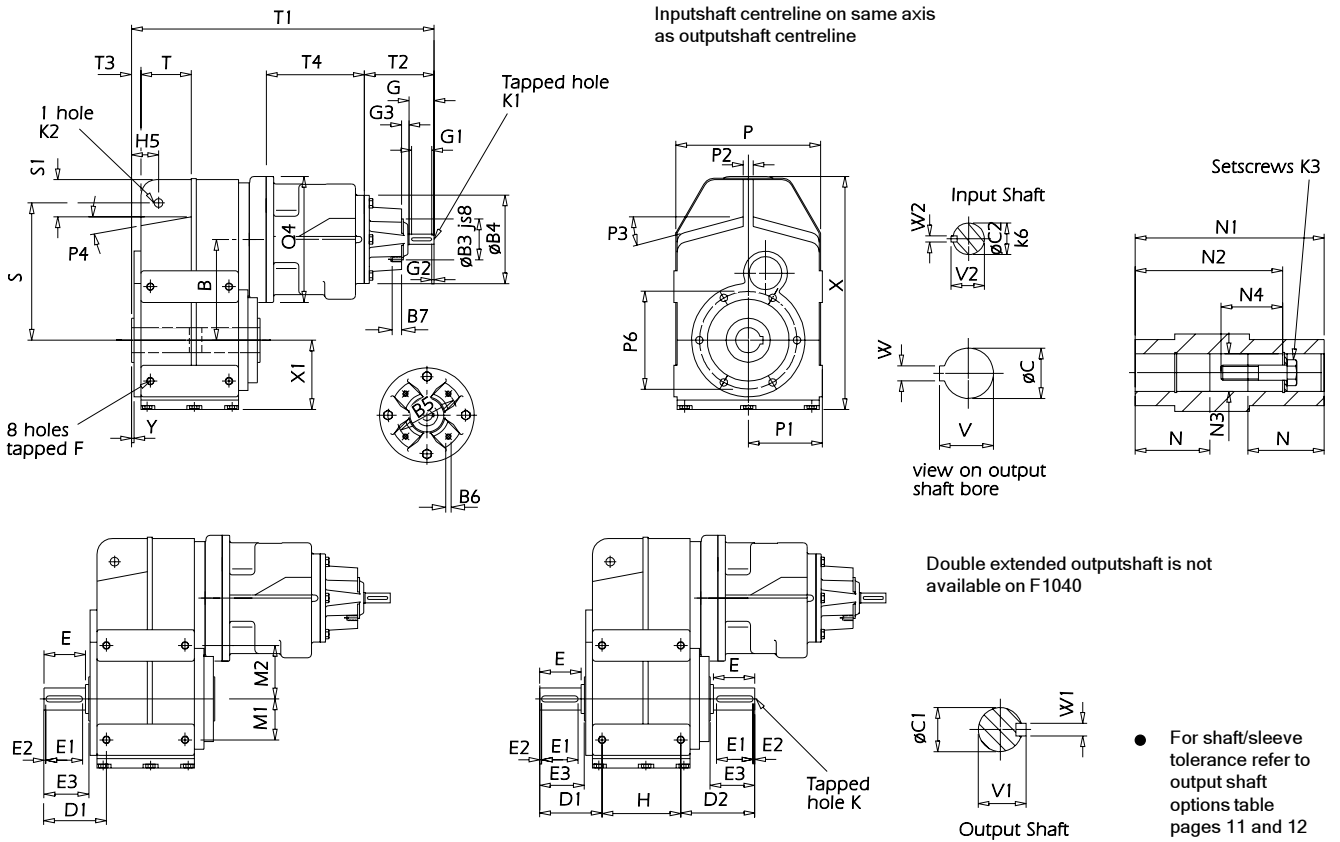

SIZE	B	øB3	øB4	øB5	B6	B7	øC	øC1	øC2	D1	D2	E	E1	E2	E3	F	G	G1	G2	G3	H
F0640	160	65	140	90	4 x M8	16	40	35	16	99	118	66	58	3	71	M12x1.75x20	40	32	4	12	125
F0740	200	65	140	90	4 x M8	16	50	50	16	121	146	86	80	3	91	M16x2x25	40	32	4	12	150
F0840	226	78	180	115	4 x M10	17	60	60	19	155	180	114	100	3	120	M16x2x24	40	32	4	22	170
F0940	274	98	212	145	4 x M12	20	70	70	24	179	218	135	110	3	141	M16x2Px24	50	40	5	23	215
F1040	332	98	250	145	4 x M12	20	80	90	28	213.5	-	172	140	5	172	M20x2Px27	60	50	5	23	250

SIZE	H5	K	K1	øK2	K3	M1	M2	N	N1	N2	N3	N4	P	P1	P2
F0640	41	M16x2x36	M5x0.8x12.5	14	M16x70L	65	85	90	200	156	40.2	66	226	118	16
F0740	50	M16x2x36	M5x0.8x12.5	22	M16x70L	85	115	105	235	183	50.2	78	266	140	20
F0840	62	M20x2.5x42	M6x1x16	22	M20x80L	100	100	117.5	265	210	60.2	92.5	320	170	26
F0940	70	M20x2.5Px42	M8x1.25x19	27	M20x80L	125	225	147.5	330	270	70.2	66	384	200	30
F1040	88	M20x2.5Px42	M10x1.5x22	27	M20x80L	158	272	165	370	313	80.2	66	454	235	36

SIZE	P3	P4	P6	Q4	S	S1	T	T1	T2	T3	T4	V	V1	V2	W	W1	W2	X	X1	Y
F0640	15°	10°	6 holes, M12x1.75x20, 150 pcd	200	218	59	80	479	111	13	156	43.5	38	18	12	10	5	367	110	2
F0740	20°	11°	6 holes, M12x1.75x20, 150 pcd	200	278	68	95	521	111	13	156	54	53.5	18	14	14	5	449	134	2
F0840	20°	11°	8 holes, M12x1.75x20, 195 pcd	250	346	79	105	610	111	15	198	64.5	64	21.5	18	18	6	526	148	3
F0940	20°	11°	6 holes, M16x2Px27, 230 pcd	300	395	100	131	720	115	19	245	75	74.5	27	20	20	8	612	175	5
F1040	17°	10°	10 holes, M16x2Px27, 280 pcd	350	485	136	152	879.5	160	19.5	295	85	95	31	22	25	8	748	216	5.5

SERIES F

DIMENSIONS

QUINTUPLE REDUCTION SIZES F06 & F07

9610

F	0	5	0			W	R
---	---	---	---	--	--	---	---

STANDARD UNIT QUINTUPLE REDUCTION

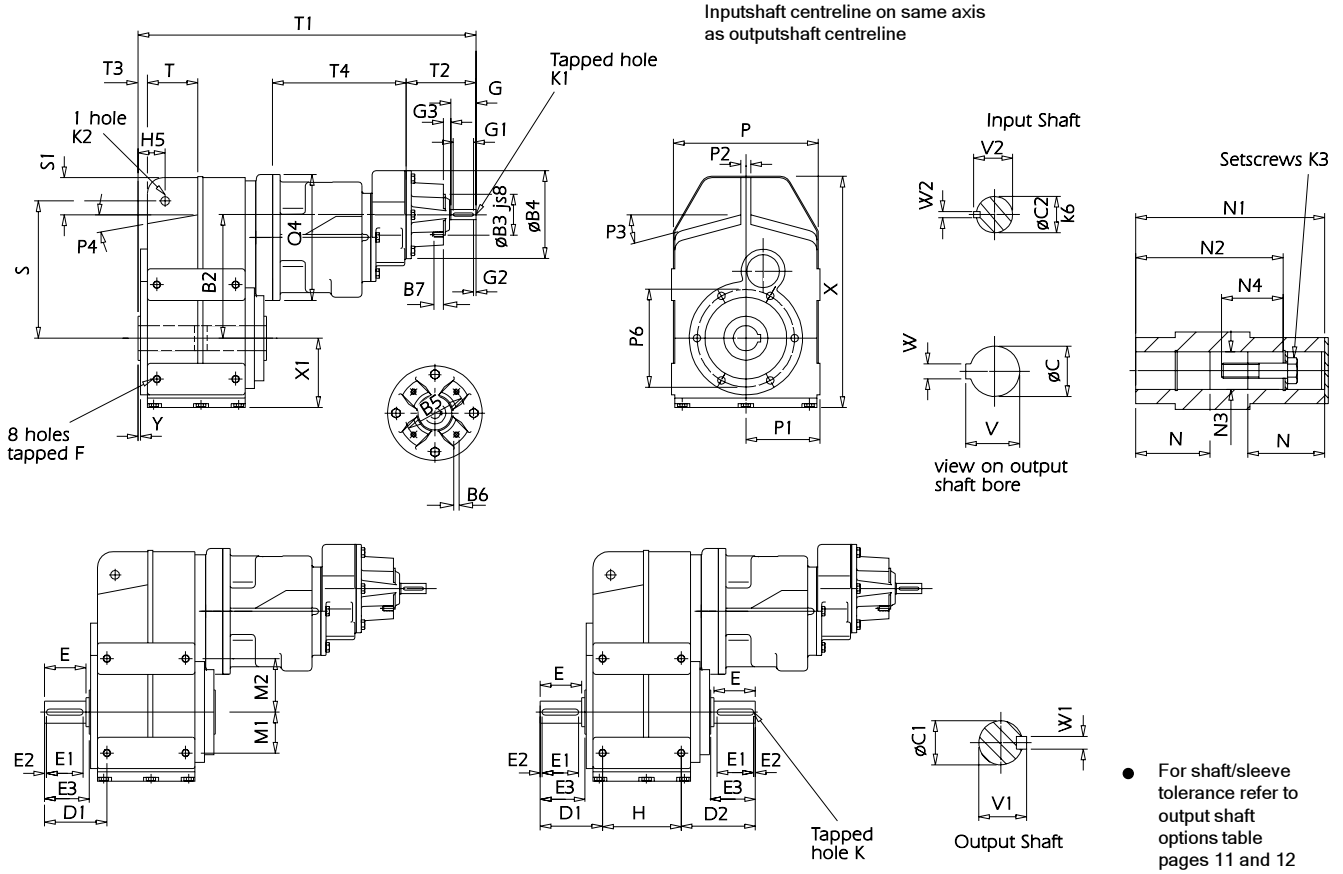

SIZE	B2	øB3	øB4	øB5	B6	B7	øC	øC1	øC2	D1	D2	E	E1	E2	E3	F	G	G1	G2	G3	H
F0650	196	65	140	90	4 x M8	16	40	35	16	99	118	66	58	3	71	M12x1.75x20	40	32	4	12	125
F0750	236	65	140	90	4 x M8	16	50	50	16	121	146	86	80	3	91	M16x2x25	40	32	4	12	150

SIZE	H5	K	K1	øK2	K3	M1	M2	N	N1	N2	N3	N4	P	P1	P2
F0650	41	M16x2x36	M5x0.8x12.5	14	M16x70L	65	85	90	200	156	40.2	66	226	118	16
F0750	50	M16x2x36	M5x0.8x12.5	22	M16x70L	85	115	105	235	183	50.2	78	266	140	20

SIZE	P3	P4	P6	Q4	S	S1	T	T1	T2	T3	T4	V	V1	V2	W	W1	W2	X	X1	Y
F0650	15°	10°	6 holes, M12x1.75x20, 150 pcd	200	218	59	80	535	111	13	212	43.5	38	18	12	10	5	367	110	2
F0750	20°	11°	6 holes, M12x1.75x20, 150 pcd	200	278	68	95	577	111	13	212	54	53.5	18	14	14	5	449	134	2

SERIES F

DIMENSIONS

QUINTUPLE REDUCTION SIZES F08, F09 & F10

9610

F			5	0				W	R
---	--	--	---	---	--	--	--	---	---

STANDARD UNIT

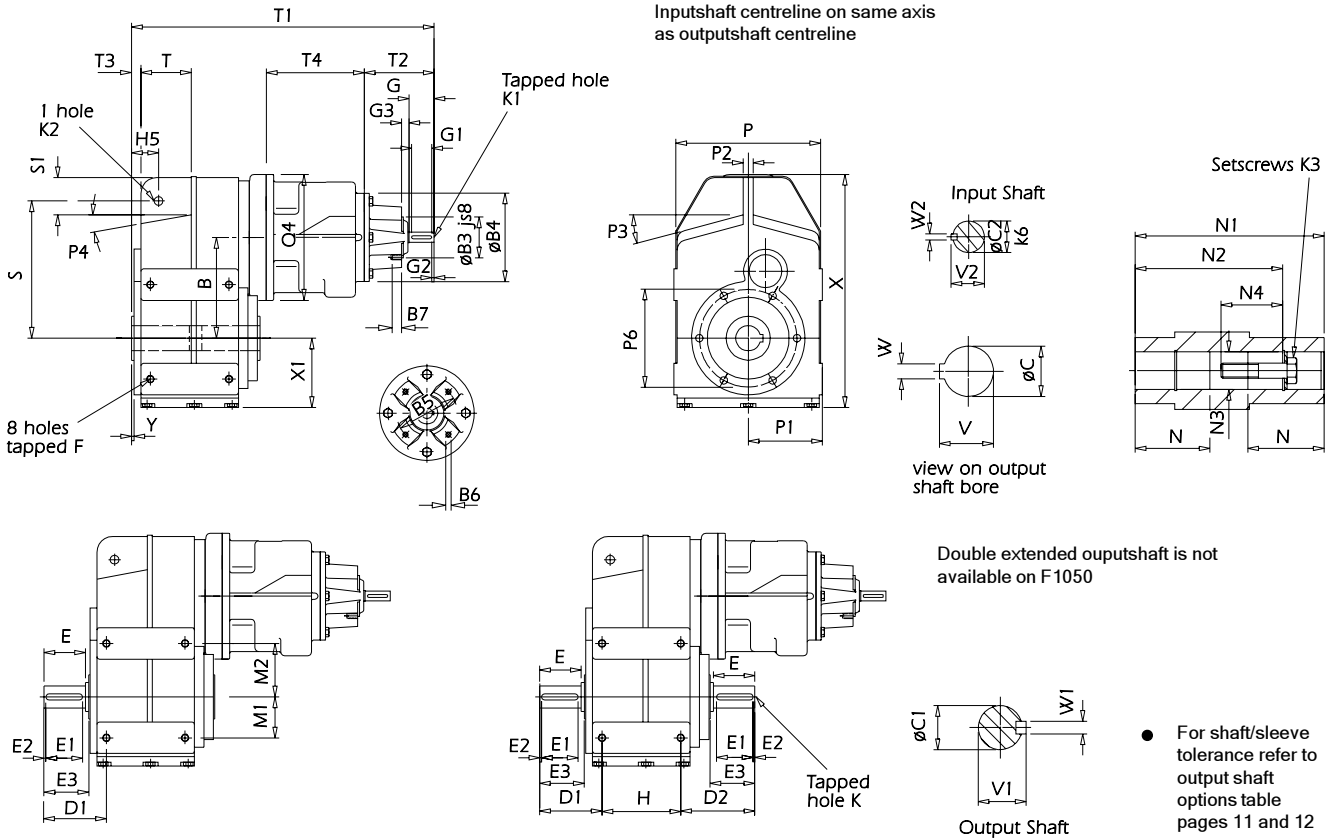

SIZE	B	øB3	øB4	øB5	B6	B7	øC	øC1	øC2	D1	D2	E	E1	E2	E3	F	G	G1	G2	G3	H
F0850	226	65	140	90	4 x M8	17	60	60	19	155	180	114	100	3	120	M16 x 2 x 24	40	32	4	12	170
F0950	274	65	140	90	4 x M8	16	70	70	16	179	218	135	110	3	141	M16 x 2P x 24	40	32	4	12	215
F1050	332	65	140	90	4 x M8	16	80	90	16	213.5	-	172	140	5	172	M20 x 2P x 27	40	32	4	12	250

SIZE	H5	K	K1	øK2	K3	M1	M2	N	N1	N2	N3	N4	P	P1	P2
F0850	62	M20 x 2.5 x 42	M5 x 0.8 x 12.5	22	M20 x 80L	100	100	117.5	265	210	60.2	92.5	320	170	26
F0950	70	M20 x 2.5P x 42	M5 x 0.8 x 12.5	27	M20 x 80L	125	225	147.5	330	270	70.2	66	384	200	30
F1050	88	M20 x 2.5P x 42	M5 x 0.8 x 12.5	27	M20 x 80L	158	272	165	370	313	80.2	66	454	235	36

SIZE	P3	P4	P6	Q4	S	S1	T	T1	T2	T3	T4	V	V1	V2	W	W1	W2	X	X1	Y
F0850	20°	11°	8 holes, M16x1.75x20, 195 pcd	250	346	79	105	579	111	15	156	64.5	64	18	18	18	5	526	148	5
F0950	20°	11°	6 holes, M16x2Px27, 230 pcd	200	395	100	131	647	111	19	156	75	74.5	18	20	20	5	612	175	5
F1050	17°	10°	10 holes, M16x2Px27, 280 pcd	200	485	136	152	707.5	111	19.5	156	85	95	18	22	25	5	748	216	5.5

SERIES F

DIMENSIONS

ALL UNITS

9703

F 0 B R

STANDARD UNIT WITH FEET

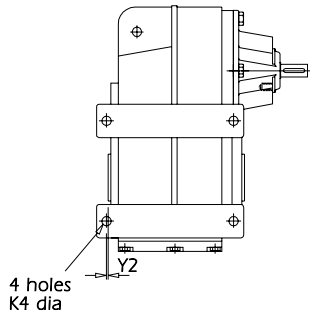

Inputshaft centreline on same axis as outputshaft centreline

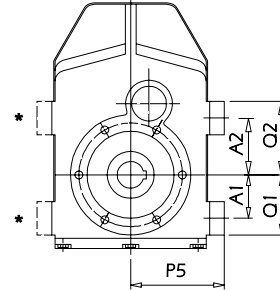

* Alternative feet position

Double extended outputshaft is not available on size F10

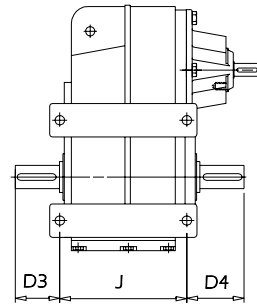
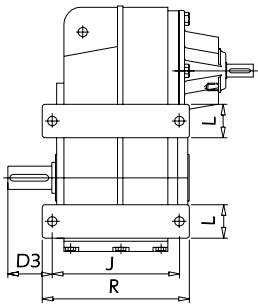

SIZE	A1	A2	D3	D4	J	K4	L	P5	Q1	Q2	R	Y2
F04	50	60	60	72	140	11	35	108	67.5	77.5	165	1
F06	65	85	66.5	85.5	190	14	50	140	90	110	220	4.5
F07	85	115	81	106	230	17.5	60	170	115	145	265	10
F08	100	110	112.5	137.5	255	17.5	60	200	130	130	290	7.5
F09	125	225	136.5	175.5	300	17.5	60	230	155	255	335	4.5
F10	158	272	163.5	-	350	22	75	270	195.5	309.5	400	8.5

SERIES F

DIMENSIONS

ALL UNITS

9706

F			0			F	R
---	--	--	---	--	--	---	---

STANDARD UNIT WITH FLANGE

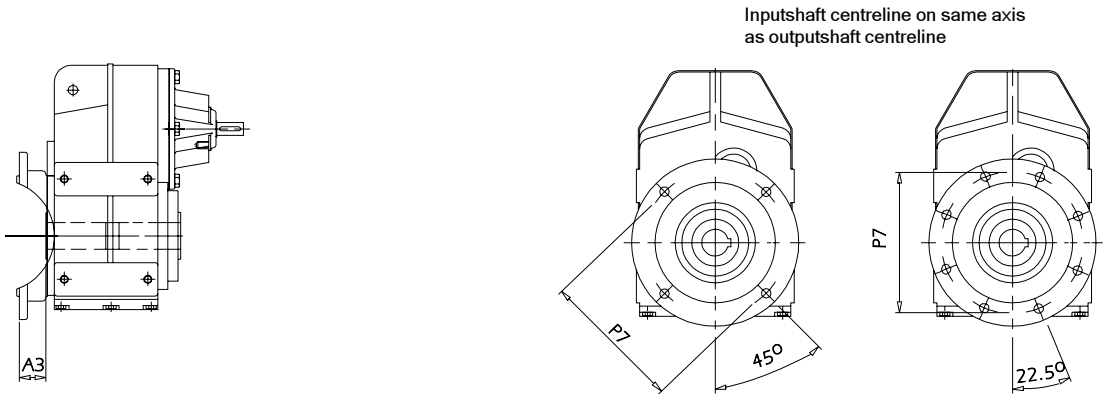

Sizes
F04, F06, F07 & F08

Sizes
F09 & F10

Double extended outputshaft is not available on size F10

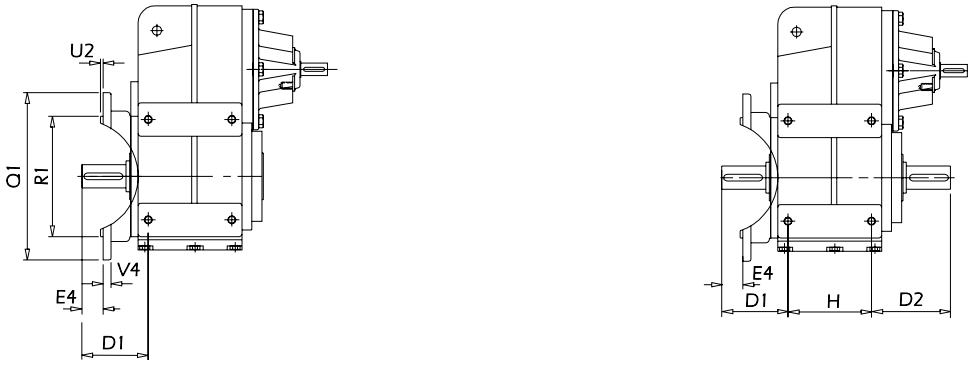

SIZE	A3	D1	D2	E4	H	P7	øQ1	øR1	U2	V4
F04	42	85	97	19	90	4 holes, 11 dia on a 165 pcd	200	130 j6	3.5	12
F06	39.5	99	118	31.5	125	4 holes, 14 dia on a 215 pcd	250	180 j6	4	12
F07	39.5	121	146	51.5	150	4 holes, 14 dia on 215 pcd	250	180 j6	4	12
F08	47	155	180	73	170	4 holes, 18 dia on a 300 pcd	350	250 h6	5	18
F09	51	179	218	90	215	8 holes, 18 dia on a 400 pcd	450	350 h6	5	20
F10	60	213.5	-	112	250	8 holes, 18 dia on a 400 pcd	450	350 h6	5	22

SERIES F

TORQUE BUSH

9606

RUBBER BUSHES FOR TORQUE ARM

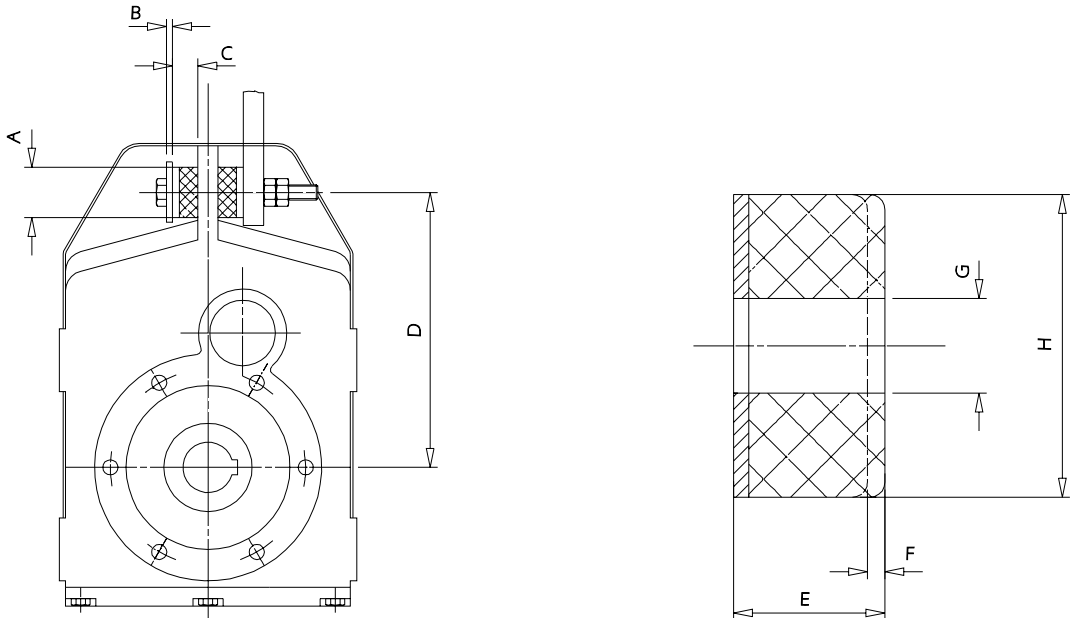

UNIT SIZE	A	B	C	D	E	F	G	H
F04	40	5	20	170	20	1.5	13.0 / 12.5	40
F06	40	5	20	218	20	2.3	13.0 / 12.5	40
F07	60	10	30	278	30	3	21.5 / 21.0	60
F08	60	10	30	346	30	4	21.5 / 21.0	60
F09	80	12	40	395	40	3.7	25.5 / 25.0	80
F10	80	12	40	485	40	6	25.5 / 25.0	80

SERIES F

DIMENSIONS

ASSEMBLY/DISASSEMBLY

9906

ASSEMBLY ONTO SHAFT - CUSTOMERS SHAFT DETAIL

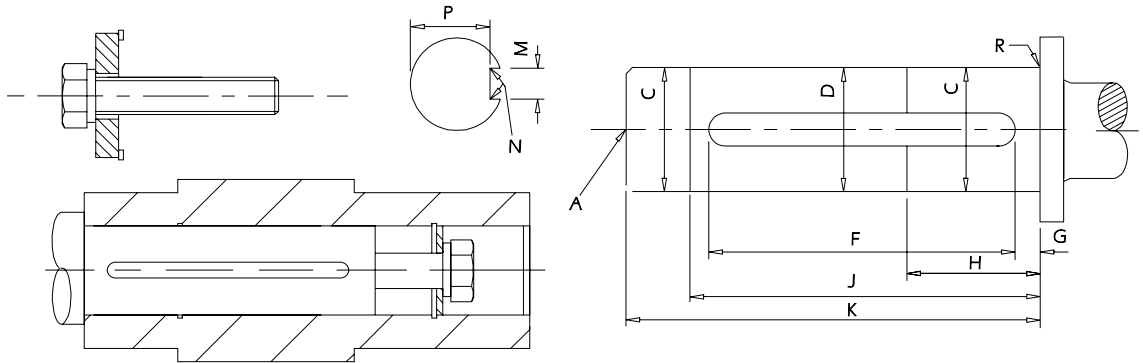

SIZE	A	C	D	F	G	H	J	K	M	N	P	R
F04	M10x 1.5 22 deep	29.993 / 29.980	29.6	79.3 79.0	2	45	84	99	8.000 / 7.964	0.25 0.16R	26.0 25.8	0.8R
F06	M16x 2.0 36 deep	39.991 / 39.975	39.6	93.3 93.0	3	60	106	126	12.000 / 11.957	0.40 0.25R	35.0 34.8	0.8R
F07	M16x 2.0 36 deep	49.991 / 49.975	49.6	101.5 101.0	3	75	128	153	14.000 / 13.957	0.40 0.25R	44.5 44.3	0.8R
F08	M20x 2.5 42 deep	59.990 / 59.971	59.6	148.5 148.0	3	90	143	173	18.000 / 17.957	0.40 0.25R	53.0 52.8	0.8R
F09	M20 x 2.5P 42 deep	69.990 / 69.971	69.6	161.5 161.0	3	105	197	232	20.000 / 19.948	0.6 0.4R	62.5 62.3	0.8R
F10	M20 x 2.5P 42 deep	79.990 / 79.971	79.6	188.5 188.0	5	120	235	275	22.000 / 21.948	0.6 0.4R	71.0 70.8	0.8R

DISASSEMBLY METHOD FROM SHAFT

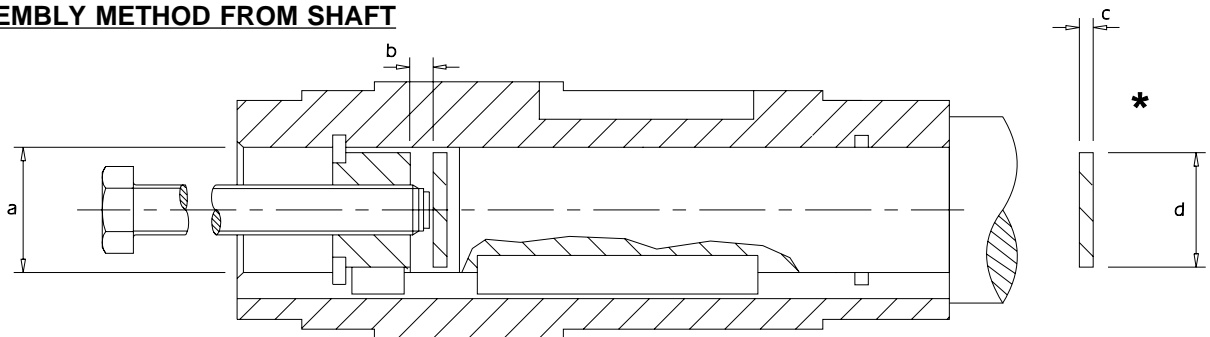

* PARTS SUPPLIED BY CUSTOMER

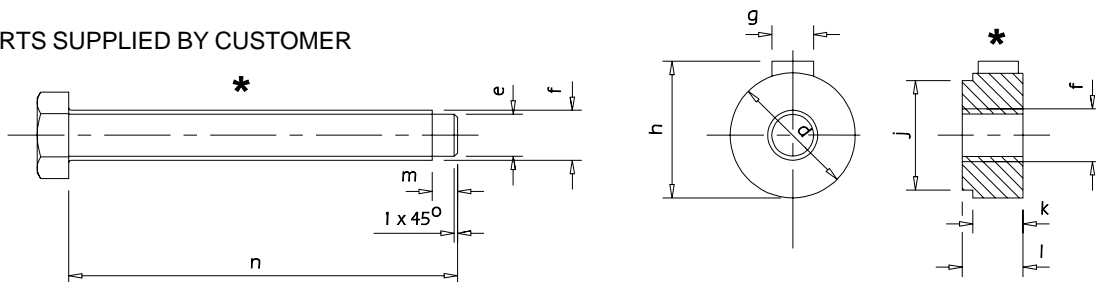

SIZE	a	b	c	d	e	f	g	h	j	k	l	m	n
F04	30	4.00	5	29.9	13	M16 x 1.5	8	33	20.8	15	17	5	120
F06	40	5.35	5	39.9	20	M24 x 1.5	12	43	29.9	20	23	5	154
F07	50	10.10	5	49.9	20	M24 x 1.5	14	53.5	39.0	20	23	5	186
F08	60	5.00	8	59.9	26	M30 x 1.5	18	64	47.4	24	27	5	205
F09	70	6.05	8	69.9	26	M30 x 1.5	20	74.5	56.4	24	27	5	273
F10	80	6.00	8	79.9	26	M30 x 1.5	25	95	75.3	24	27	5	316

SERIES F

SHIPPING SPECIFICATION

9606

UNIT SIZE & No OF REDUCTIONS		F0420			F0430			F0620			F0630			F0640			F0650			F0720			
COLUMN 9 ENTRY		W	B	F	W	B	F	W	B	F	W	B	F	W	B	F	W	B	F	W	B	F	
OUTPUT SHAFT		0.8			0.8			1.7			1.7			1.7			1.7			3.3			
REDUCER VERSION		19	21	22	22	24	25	43	48	48	48	52	52	55	60	60	59	64	64	70	77	79	
MOTORISED	63	Without Motor	19	21	22	22	24	25	42	46	46	47	51	51	54	59	59	<i>58</i>	<i>63</i>	<i>63</i>			
		With Motor	23	25	26	26	28	29	49	53	53	51	55	55	58	63	63						
		With Motor & Brake	24	26	27	27	29	30	50	54	54	52	56	56	59	64	64						
	71	Without Motor	19	21	22	22	24	25	42	46	46	47	51	51	54	59	59	<i>58</i>	<i>63</i>	<i>63</i>			
		With Motor	26	28	29	29	31	32	49	53	53	54	58	58	61	66	66						
		With Motor & Brake	27	29	30	30	32	33	50	54	54	55	59	59	62	67	67						
	80	Without Motor	20	22	23	23	25	26	43	47	47	48	52	52	<i>55</i>	<i>60</i>	<i>60</i>	<i>59</i>	<i>64</i>	<i>64</i>	67	74	76
		With Motor	30	32	33	33	35	36	53	57	57	58	62	62							77	84	86
		With Motor & Brake	32	34	35	35	37	38	55	59	59	60	64	64							79	86	88
	90S	Without Motor	20	22	23	23	25	26	44	48	48	49	55	53	<i>56</i>	<i>61</i>	<i>61</i>				67	74	76
		With Motor	33	35	36	36	38	39	57	61	61	62	66	66							80	87	89
		With Motor & Brake	36	38	39	39	41	42	60	64	64	65	69	69	72	76	76				83	90	92
	90L	Without Motor	20	22	23	23	25	26	44	48	48	49	53	53	<i>56</i>	<i>61</i>	<i>61</i>				67	74	76
		With Motor	35	37	39	38	40	41	59	63	63	64	68	68							82	89	91
		With Motor & Brake	38	40	41	41	43	44	62	66	66	67	71	71	74	78	78				85	92	94
	100	Without Motor	21	23	24	<i>24</i>	<i>26</i>	<i>27</i>	48	52	52	50	54	54							72	79	81
		With Motor	43	45	46	46	48	49	70	74	74	72	76	76							94	101	103
		With Motor & Brake	48	50	51	51	53	54	75	79	79	77	81	81							99	106	108
	112	Without Motor	21	23	24	<i>24</i>	<i>26</i>	<i>27</i>	48	52	52	<i>50</i>	<i>54</i>	<i>54</i>							72	79	81
		With Motor	52	54	55				79	83	83										103	110	112
		With Motor & Brake	57	59	60				84	88	88										108	115	117
	132S	Without Motor							50	54	54										74	81	83
		With Motor							92	96	96										116	123	125
		With Motor & Brake							101	105	105										125	132	134
132M	Without Motor							50	54	54										74	81	83	
	With Motor							102	106	106										126	133	135	
	With Motor & Brake							111	115	115										135	142	144	
160L160M	Without Motor																			78	85	87	
	With Motor																			150	157	159	
	With Motor & Brake																			163	170	172	

UNIT SIZE & No OF REDUCTIONS		F0730			F0740			F0750			F0820			F0830			F0840			F0850			
COLUMN 9 ENTRY		W	B	F	W	B	F	W	B	F	W	B	F	W	B	F	W	B	F	W	B	F	
OUTPUT SHAFT		3.3			3.3			3.3			7.0			7.0			7.0			7.0			
REDUCER VERSION		77	84	86	95	102	104	99	106	108	102	110	119	109	117	126	129	137	146	133	141	158	
MOTORISED	63	Without Motor	75	82	84	92	99	101	<i>97</i>	<i>104</i>	<i>106</i>							127	135	144	<i>126</i>	<i>134</i>	<i>151</i>
		With Motor	79	86	88	96	103	105										131	139	148			
		With Motor & Brake	80	87	89	97	104	106										132	140	149			
	71	Without Motor	75	82	84	92	99	101	<i>97</i>	<i>104</i>	<i>106</i>							127	135	144	<i>126</i>	<i>134</i>	<i>151</i>
		With Motor	82	89	91	99	106	108										134	142	151			
		With Motor & Brake	83	90	92	100	107	109										135	143	152			
	80	Without Motor	76	83	85	93	100	102	<i>98</i>	<i>105</i>	<i>107</i>	105	113	122	110	118	127	128	136	145	<i>127</i>	<i>135</i>	<i>152</i>
		With Motor	86	93	95	103	110	112				115	123	132	120	128	137	138	146	155			
		With Motor & Brake	88	95	97	105	112	114				117	125	134	122	130	139	140	148	157			
	90S	Without Motor	77	84	86	<i>93</i>	<i>100</i>	<i>102</i>	<i>99</i>	<i>106</i>	<i>108</i>	105	113	122	110	118	127	128	136	145	<i>127</i>	<i>135</i>	<i>152</i>
		With Motor	90	97	99							118	126	135	123	131	140	141	149	156			
		With Motor & Brake	93	100	102							121	129	138	126	134	143	144	152	161			
	90L	Without Motor	77	84	86	<i>93</i>	<i>100</i>	<i>102</i>	<i>99</i>	<i>106</i>	<i>108</i>	105	113	122	110	118	127	128	136	145	<i>129</i>	<i>137</i>	<i>154</i>
		With Motor	92	99	101							121	129	138	129	137	146	142	150	159			
		With Motor & Brake	95	102	104							124	132	141	132	141	149	145	153	162			
	100	Without Motor	81	88	90	<i>98</i>	<i>105</i>	<i>107</i>				105	113	122	110	118	127	<i>133</i>	<i>141</i>	<i>150</i>	<i>138</i>	<i>146</i>	<i>163</i>
		With Motor	103	110	112							127	135	144	132	140	149						
		With Motor & Brake	108	115	117							132	140	149	137	145	154						
	112	Without Motor	81	88	90	<i>98</i>	<i>105</i>	<i>107</i>				105	113	122	110	118	127	<i>133</i>	<i>141</i>	<i>150</i>	<i>138</i>	<i>146</i>	<i>163</i>
		With Motor	112	119	121							136	144	153	141	149	158						
		With Motor & Brake	117	124	126							141	149	158	146	154	163						
	132S	Without Motor	83	90	92							105	113	122	112	120	129	<i>135</i>	<i>143</i>	<i>152</i>	<i>140</i>	<i>148</i>	<i>165</i>
		With Motor	125	132	134							147	155	164	170	178	187						
		With Motor & Brake	134	141	143							156	164	173	179	187	196						
132M	Without Motor	<i>83</i>	<i>90</i>	<i>92</i>							105	113	122	112	120	129	<i>135</i>	<i>142</i>	<i>152</i>	<i>140</i>	<i>148</i>	<i>165</i>	
	With Motor										157	165	174	164	172	181							
	With Motor & Brake										166	174	183	173	181	190							
160L160M	Without Motor										115	123	132	<i>116</i>	<i>124</i>	<i>133</i>							
	With Motor										177	185	194										
	With Motor & Brake										115	123	132	<i>116</i>	<i>124</i>	<i>133</i>							

FIGURES IN ITALICS INDICATE THAT FRAME SIZE CAN BE FITTED BUT IS BEYOND THE MECHANICAL RATING OF THE UNIT
 ALL WEIGHTS IN KG ALL WEIGHTS EXCLUDE LUBRICANT AND ARE FOR SHAFT MOUNTED UNITS, SHAFT WEIGHTS (GIVEN AT THE TOP OF THE TABLE) MUST BE ADDED TO THE FIGURES SHOWN ABOVE

COLUMN 9 ENTRY

W
F

 - STANDARD UNIT

B

 - STANDARD UNIT WITH BASE MOUNTED FEET

F

 - STANDARD UNIT WITH OUTPUT FLANGE

SERIES F

SHIPPING SPECIFICATION

9609

UNIT SIZE & No OF REDUCTIONS		F0920			F0930			F0940			F0950			F1020			F1030			F1040			F1050			
COLUMN 9 ENTRY		W	B	F	W	B	F	W	B	F	W	B	F	W	B	F	W	B	F	W	B	F	W	B	F	
OUTPUT SHAFT		10.8			10.8			10.8			10.8			18.5			18.5			18.5			18.5			
REDUCER VERSION		171	180	186	180	189	195	218	227	233	197	206	212	261	276	287	270	285	296	332	347	358	286	301	312	
MOTORISED	63	Without Motor									197	206	212										286	301	312	
		With Motor										201	210	216										290	305	316
		With Motor & Brake										202	211	217										291	306	317
	71	Without Motor										197	206	212										286	301	312
		With Motor										203	212	218										292	307	318
		With Motor & Brake										204	213	219										293	308	319
	80	Without Motor	174	183	189	184	193	199	215	224	230	198	207	213				273	288	299	336	351	362	287	302	313
		With Motor	184	193	199	194	203	209	224	233	239	207	216	222				283	298	309	345	360	371	296	311	322
		With Motor & Brake	186	195	201	196	205	211	226	235	241	209	218	224				284	299	310	347	362	373	298	313	324
	90S	Without Motor	174	183	189	184	193	199	215	224	230	198	207	213				273	288	299	336	351	362	287	302	313
		With Motor	187	196	202	197	206	212	228	237	243	211	220	226				286	301	312	349	364	375	300	315	326
		With Motor & Brake	189	198	204	200	209	215	231	240	246	214	223	229				289	304	315	351	366	377	303	318	329
	90L	Without Motor	174	183	189	184	193	199	215	224	230	198	207	213				273	288	299	336	351	362	287	302	313
		With Motor	189	198	204	199	208	214	231	240	246	214	223	229				288	303	314	351	366	377	303	318	329
		With Motor & Brake	192	201	207	202	211	217	234	243	249	217	226	232				291	306	317	354	369	380	306	321	332
	100	Without Motor	174	183	189	184	193	199	221	230	236	199	208	214	254	269	280	273	288	299	336	351	362	288	303	314
		With Motor	186	195	201	226	235	241	242	251	257	221	230	236	276	291	302	295	310	321	357	372	383	310	325	336
		With Motor & Brake	201	210	216	231	240	246	247	256	262	226	235	241	281	296	307	300	315	326	362	377	388	315	330	341
	112	Without Motor	174	183	189	184	193	199	221	230	236	199	208	214	254	269	280	273	288	299	336	351	362	288	303	314
		With Motor	205	214	220	215	224	230	251	260	266	230	239	245	285	300	311	304	319	330	367	382	393	319	334	345
		With Motor & Brake	210	219	225	219	228	234	256	265	271	235	244	250	290	305	316	309	324	335	374	389	400	324	339	350
	132S	Without Motor	174	183	189				222	231	237				254	269	280	273	288	299	336	351	362			
		With Motor	216	225	231				264	273	279				296	311	322	315	330	341	378	393	404			
		With Motor & Brake	225	234	240				273	282	288				305	320	331	324	339	350	387	402	413			
	132M	Without Motor	174	183	189				222	231	237				254	269	280	273	288	299	336	351	362			
		With Motor	226	235	241				274	283	289				306	321	332	325	340	351	388	403	414			
		With Motor & Brake	235	244	250				283	292	298				315	330	341	334	349	360	397	412	423			
	160M	Without Motor	181	190	196				226	235	241				263	278	289	280	295	306	346	361	372			
		With Motor	253	262	268				298	307	313				335	350	361	352	367	378	418	433	444			
	160L	Without Motor	181	190	196				226	235	241				263	278	289	280	295	306	346	361	372			
With Motor		266	275	281				311	320	326				335	350	361	365	380	391	431	446	457				
180M	Without Motor	181	190	196										263	278	289	280	295	306							
	With Motor	289	298	304										371	386	397	388	403	414							
180L	Without Motor	181	190	196										263	278	289	280	295	306							
	With Motor	325	334	340										407	422	433	424	439	450							
200L	Without Motor	181	190	196										263	278	289	281	296	307							
	With Motor	349	358	364										431	446	457	449	464	475							
225SS	Without Motor	195	204	210										277	292	303	295	310	321							
	With Motor	402	411	417										484	499	510	502	517	528							
225M	Without Motor	195	204	210										277	292	303	295	310	321							
	With Motor	420	429	435										502	517	528	520	535	546							

ALL WEIGHTS IN KG

ALL WEIGHTS EXCLUDE LUBRICANT AND ARE FOR SHAFT MOUNTED UNITS, SHAFT WEIGHTS (GIVEN AT THE TOP OF THE TABLE) MUST BE ADDED TO THE FIGURES SHOWN ABOVE

COLUMN 9 ENTRY

W

- STANDARD UNIT

B

- STANDARD UNIT WITH BASE MOUNTED FEET

F

- STANDARD UNIT WITH OUTPUT FLANGE

SERIES F

SHIPPING SPECIFICATION

VOLUME

9606

UNIT SIZE & No OF REDUCTIONS		F0420		F0430		F0620		F0630		F0720		F0730		F0820		F0830		
COLUMN 11 ENTRY		H	C/D	H	C/D	H	C/D	H	C/D	H	C/D	H	C/D	H	C/D	H	C/D	
REDUCER VERSION		0.012	0.014	0.016	0.019	0.025	0.030	0.032	0.038	0.040	0.051	0.054	0.066	0.069	0.089	0.066	0.086	
MOTORISED	63	With Motor	0.015	0.018	0.020	0.023	0.031	0.036	0.038	0.044			0.054	0.064				
		Without Motor	0.006	0.009	0.010	0.013	0.015	0.021	0.022	0.028			0.033	0.043				
	71	With Motor	0.016	0.019	0.021	0.024	0.033	0.039	0.041	0.047			0.057	0.067				
		Without Motor	0.007	0.009	0.010	0.013	0.016	0.022	0.022	0.029			0.034	0.044				
	80	With Motor	0.018	0.021	0.023	0.026	0.035	0.041	0.044	0.050	0.047	0.056	0.059	0.069	0.091	0.111	0.092	0.112
		Without Motor	0.007	0.010	0.011	0.014	0.016	0.022	0.024	0.030	0.023	0.033	0.034	0.044	0.052	0.072	0.053	0.073
	90	With Motor	0.020	0.023			0.039	0.045	0.048	0.054	0.052	0.061	0.065	0.074	0.097	0.117	0.100	0.120
		Without Motor	0.008	0.011			0.017	0.022	0.024	0.031	0.024	0.034	0.035	0.045	0.052	0.072	0.055	0.075
	100/112	With Motor	0.024	0.027			0.048	0.054	0.055	0.061	0.061	0.071	0.077	0.087	0.110	0.130	0.116	0.136
		Without Motor	0.008	0.011			0.020	0.026	0.025	0.031	0.027	0.036	0.040	0.050	0.053	0.073	0.059	0.079
	132	With Motor					0.054	0.060			0.068	0.077	0.084	0.094	0.121	0.141	0.127	0.147
		Without Motor					0.020	0.026			0.027	0.036	0.040	0.050	0.053	0.073	0.059	0.079
	160	With Motor									0.085	0.094			0.148	0.169	0.155	0.175
		Without Motor									0.030	0.039			0.058	0.078	0.064	0.084

UNIT SIZE & No OF REDUCTIONS		F0920		F0930		F1020		F1030		
COLUMN 11 ENTRY		H	C/D	H	C/D	H	C/D	H	C/D	
REDUCER VERSION										
MOTORISED	80	With Motor	0.182	0.208	0.190	0.230			0.290	0.359
		Without Motor	0.116	0.157	0.124	0.164			0.197	0.266
	90	With Motor	0.194	0.234	0.201	0.242			0.306	0.375
		Without Motor	0.116	0.157	0.124	0.164			0.197	0.266
	100/112	With Motor	0.215	0.242	0.223	0.263	0.314	0.383	0.336	0.406
		Without Motor	0.118	0.158	0.125	0.166	0.177	0.246	0.200	0.269
	132	With Motor	0.233	0.274			0.338	0.408	0.361	0.431
		Without Motor	0.118	0.158			0.177	0.246	0.200	0.269
	160	With Motor	0.282	0.323			0.407	0.476	0.430	0.499
		Without Motor	0.128	0.168			0.191	0.260	0.214	0.282
	180	With Motor	0.304	0.344			0.437	0.507	0.460	0.529
		Without Motor	0.128	0.168			0.191	0.260	0.214	0.282
	200	With Motor	0.304	0.344			0.437	0.507	0.460	0.529
		Without Motor	0.128	0.168			0.191	0.260	0.214	0.282
	225	With Motor	0.334	0.374			0.479	0.548	0.491	0.560
		Without Motor	0.136	0.176			0.202	0.271	0.224	0.292

ALL VOLUMES IN m³

COLUMN 11 ENTRY H - STANDARD UNIT WITHOUT SHAFT
C D - STANDARD UNIT WITH SINGLE OR DOUBLE EXTENSION OUTPUT SHAFT

SERIES F

THERMAL POWER RATING

9904

Thermal Ratings kW

Thermal ratings are a measure of the units ability to dissipate heat, if they are exceeded the lubricant may break down resulting in premature gear failure.

Thermal Power (kW)

Overall Ratios	Input Rev/min	Unit Size					
		F04	F06	F07	F08	F09	F10
5 to 20	2900	Consult Textron Power Transmission					
	1750	8.2	15.0	21.3	27.8	41.0	59.2
	< 1450	8.4	15.4	22.0	29.5	42.6	61.2
22 to 56	2900	6.1	10.9	15.7	20.8	30.1	43.3
	1750	7.4	14.5	19.4	25.0	38.7	56.2
	< 1450	7.4	14.5	19.4	25.0	39.3	58.7
63 & over	2900	3.7	7.9	11.1	14.6	21.1	30.1
	1750	6.7	12.4	16.9	23.0	33.6	49.6
	< 1450	6.7	12.4	16.9	23.2	34.0	49.9

Thermal Power (kW) with cooling fan

Overall Ratios	Input Rev/min	Unit Size					
		F04	F06	F07	F08	F09	F10
5 to 20	2900	Consult Textron Power Transmission					
	1750	n/a	n/a	47.9	62.6	92.3	133
	1450			44.0	59.0	85.2	122
	1160			41.8	56.1	80.9	116
	960			27.5	36.4	52.7	75.8
	725			29.1	37.5	58.1	84.3
22 & over	2900			n/a	n/a	35.3	46.8
	1750	43.7	56.3			87.1	126
	1450	38.8	50.0			78.6	117
	1160	36.9	47.5			74.7	112
	960	34.0	43.8			68.8	103
	725	29.1	37.5			59.0	88.1

Note: When checking thermal capacities use actual load required to be transmitted, not rating of prime mover.

SERIES F

FAN COOLED UNITS

0002

Column 10 Entry

For reducer fan kit modules enter S in column 10
 (or Y if used in conjunction with a reducer backstop module kit)

Dimensions of fan cooled units

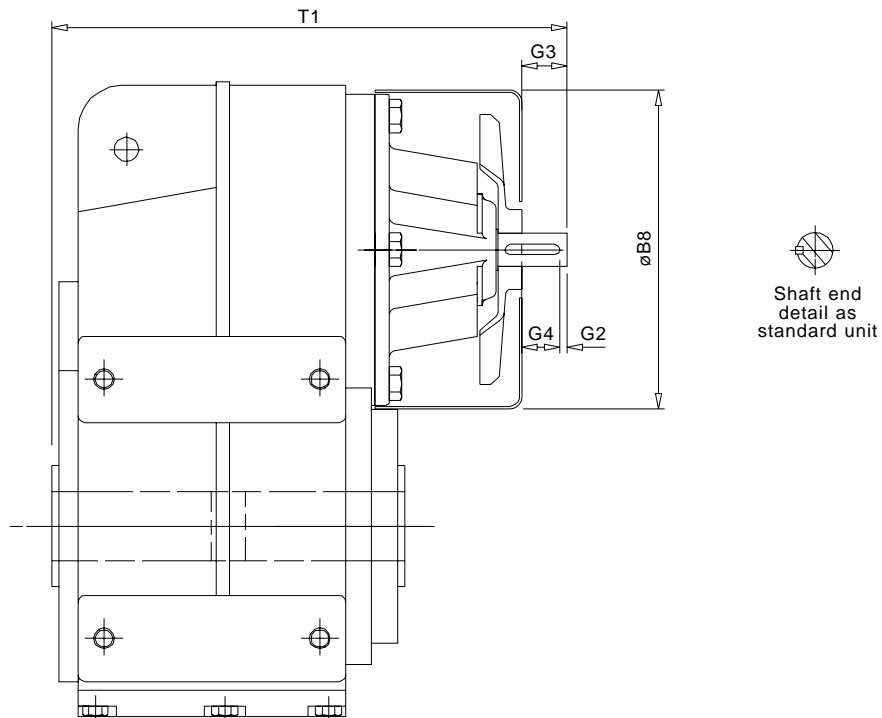

Unit Size	Moment of Inertia* (Kg cm ²)	øB8	G2	G3	G4	T1
F0720	13.1	225	5	35	30	335
F0820	13.1	265	5	45	40	408
F0920	33.5	320	5	65	60	491
F1020	33.5	380	10	95	85	575.5

* Moment of Inertia of fan should be added to inertia value of gear unit on page 73.

SERIES F

DIMENSIONS (mm)

TAPER RELEASE BUSHING

9907

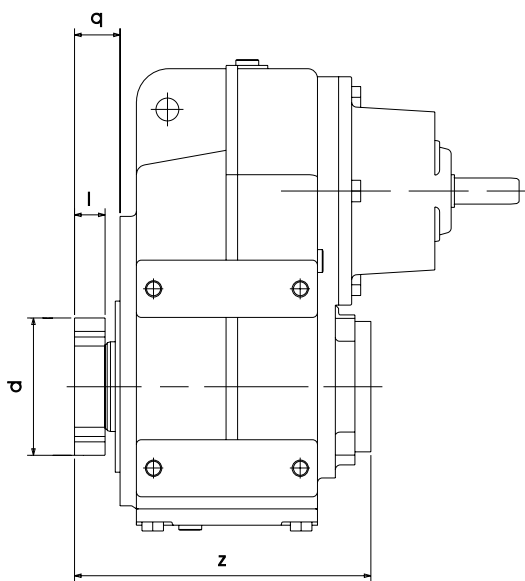

Driven shaft

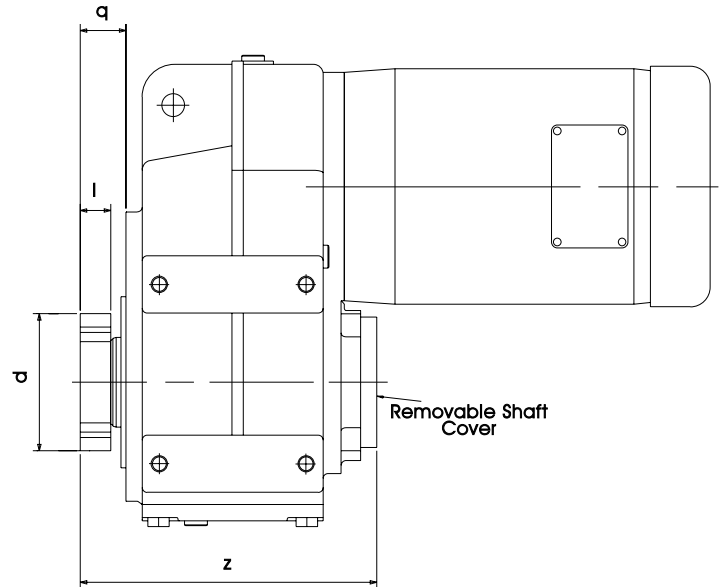

Thin walled

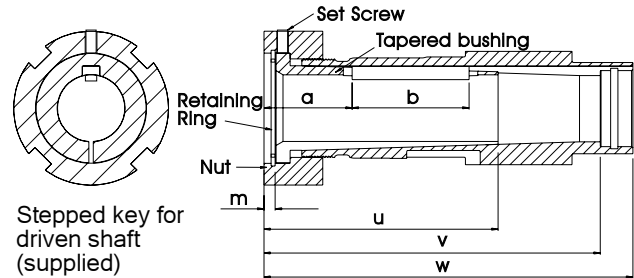
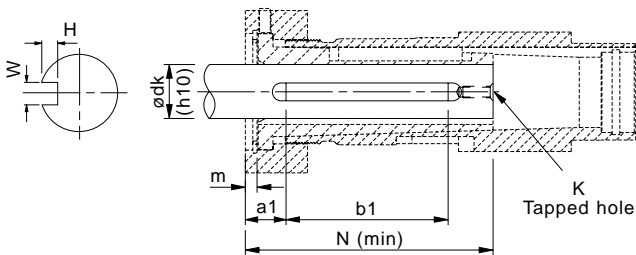

Stepped key for driven shaft (supplied)

End plate (not supplied)

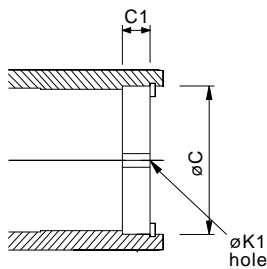

Hollow shaft key (supplied)

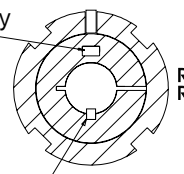

Square key for driven shaft (not supplied)

Thick walled

- Consult standard unit selection tables for kW and torque ratings

SIZE	key		bush	hollow shaft			nut			gear unit	
	a	b	u	v	w	d	l	m	q	z	
F04 (107)TR	48	64	127	190	208	84	32	7	55	210	
F06 (115)TR	53	70	141	216	251	103	37	8	49	258	
F07 (203)TR	40	83	141	243	287	108	37	8	50	300	
F08 (207)TR	32	108	155	274	318	122	37	8	52	321	
F09 (215)TR	53	89	180	330	380	145	45	10	57	400	
F10 (307)TR	40	127	188	366	426	154	45	10	61	440	

- All other gear unit dimensions may be obtained from the standard unit dimension pages

SERIES F

DIMENSIONS (mm)

TAPER RELEASE BUSHING

9907

size	Driven shaft diameter* (ødk)	bushing style	driven shaft keyway			driven shaft			end plate			circlip	bushing weight (kg)
			width (W)	depth (H)	min length ▲ (b1)	a1	K	N (min)	øC	C1	K1		
F04 (107)TR	25	Thick	8	4	110	-	M12	127	41	7.5	M16	N1300-0162	1.0
	30	Thick	8	4	110	-	M12	127	41	7.5	M16	N1300-0162	0.8
	32	Thin	10	5	74	48	M12	127	41	7.5	M16	N1300-0162	0.7
	35	Thin	10	5	74	48	M12	127	41	7.5	M16	N1300-0162	0.6
F06 (115)TR	30	Thick	8	4	125	-	M12	141	57	9	M16	N1300-0225	2.0
	32	Thick	10	5	125	-	M12	141	57	9	M16	N1300-0225	2.0
	35	Thick	10	5	125	-	M12	141	57	9	M16	N1300-0225	1.7
	38	Thick	10	5	125	-	M12	141	57	9	M16	N1300-0225	1.5
	40	Thin	12	5	82	53	M12	141	57	9	M16	N1300-0225	1.5
	42	Thin	12	5	82	53	M12	141	57	9	M16	N1300-0225	1.3
F07 (203)TR	45	Thin	14	5.5	84	53	M12	141	57	9	M16	N1300-0225	1.0
	35	Thick	10	5	125	-	M16	141	61	11	M20	N1300-0244	2.4
	38	Thick	10	5	125	-	M16	141	61	11	M20	N1300-0244	2.2
	40	Thick	12	5	125	-	M16	141	61	11	M20	N1300-0244	2.0
	42	Thick	12	5	125	-	M16	141	61	11	M20	N1300-0244	1.9
	45	Thick	14	5.5	100	-	M16	141	61	11	M20	N1300-0244	1.4
F08 (207)TR	50	Thin	14	5.5	97	40	M16	141	61	11	M20	N1300-0244	1.4
	55	Thin	16	6	99	40	M16	141	61	11	M20	N1300-0244	1.0
	40	Thick	12	5	155	-	M16	155	71	11	M20	N1300-0281	3.0
	42	Thick	12	5	155	-	M16	155	71	11	M20	N1300-0281	3.0
	45	Thick	14	5.5	155	-	M16	155	71	11	M20	N1300-0281	2.8
	50	Thin	14	5.5	122	32	M16	155	71	11	M20	N1300-0281	2.4
F09 (215)TR	55	Thin	16	6	124	32	M16	155	71	11	M20	N1300-0281	2.0
	60	Thin	18	7	126	32	M16	155	71	11	M20	N1300-0281	1.4
	50	Thick	14	5.5	180	-	M20	180	84	12.5	M24	N1300-0334	5.0
	55	Thick	16	6	180	-	M20	180	84	12.5	M24	N1300-0334	4.6
	60	Thick	18	7	180	-	M20	180	84	12.5	M24	N1300-0334	4.6
F10 (307)TR	65	Thin	18	7	107	53	M20	180	84	12.5	M24	N1300-0334	3.4
	70	Thin	20	7.5	109	53	M20	180	84	12.5	M24	N1300-0334	2.7
	60	Thick	18	7.0	180	-	M24	188	95	14	M30	N1300-0375	7.0
	65	Thick	18	7.0	180	-	M24	188	95	14	M30	N1300-0375	6.4
	70	Thin	20	7.5	147	40	M24	188	95	14	M30	N1300-0375	5.7
	75	Thin	20	7.5	147	40	M24	188	95	14	M30	N1300-0375	5.0
F10 (307)TR	80	Thin	22	9.0	149	40	M24	188	95	14	M30	N1300-0375	5.0
	85	Thin	22	9.0	149	40	M24	188	95	14	M30	N1300-0375	3.3

* Check strength of driven shaft

▲ Check strength and length of key (when key not supplied ie thick wall bushing)

SERIES F

REDUCER BACKSTOP MODULE

0004

The reducer units listed below can be fitted with an internal backstop, this has no effect of the external unit size. The backstop device incorporates high quality centrifugal lift off sprags which are wear free above the lift off speed (n min). To ensure correct operation input speed must exceed lift off speed.

Suitable for ambient temperature -40°C to + 50°C

Column 10 Entry

For reducer backstop modules enter X in column 10
(or Y if used in conjunction with a fan kit)

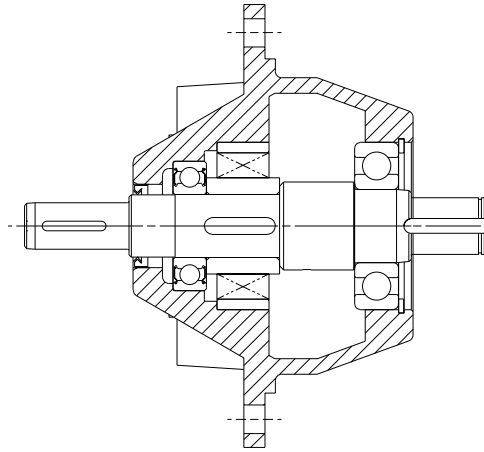

Unit Size	Lift off Speed ('n' min) (at inputshaft) (rev/min)	Rated Locking Torque ('T max') (at inputshaft) (Nm)
F0720	670	170
F0820	670	300
F0830	670	170
F0920	620	940
F0930	670	300
F1020	550	1260
F1030	670	300

Rotation of outputshaft must be specified when ordering as viewed from the outputshaft end (as shown in the diagram)

CW	-	Free Rotation	-	Clockwise
		Locked	-	Anticlockwise
AC	-	Free Rotation	-	Anticlockwise
		Locked	-	Clockwise

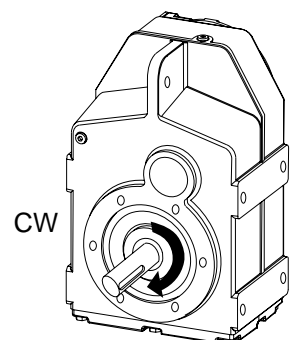

SERIES F

NOTES

SERIES F

NOTES

IMPORTANT

Product Safety Information

General - The following information is important in ensuring safety. It must be brought to the attention of personnel involved in the selection of Textron Power Transmission equipment, those responsible for the design of the machinery in which it is to be incorporated and those involved in its installation, use and maintenance.

Textron Power Transmission equipment will operate safely provided it is selected, installed, used and maintained properly. As with any power transmission equipment proper precautions must be taken as indicated in the following paragraphs, to ensure safety.

Potential Hazards - these are not necessarily listed in any order of severity as the degree of danger varies in individual circumstances. It is important therefore that the list is studied in its entirety:-

- 1) Fire/Explosion
 - (a) Oil mists and vapour are generated within gear units. It is therefore dangerous to use naked lights in the proximity of gearbox openings, due to the risk of fire or explosion.
 - (b) In the event of fire or serious overheating (over 300 °C), certain materials (rubber, plastics, etc.) may decompose and produce fumes. Care should be taken to avoid exposure to the fumes, and the remains of burned or overheated plastic/rubber materials should be handled with rubber gloves.
- 2) Guards - Rotating shafts and couplings must be guarded to eliminate the possibility of physical contact or entanglement of clothing. It should be of rigid construction and firmly secured.
- 3) Noise - High speed gearboxes and gearbox driven machinery may produce noise levels which are damaging to the hearing with prolonged exposure. Ear defenders should be provided for personnel in these circumstances. Reference should be made to the Department of Employment Code of Practice for reducing exposure of employed persons to noise.
- 4) Lifting - Where provided (on larger units) only the lifting points or eyebolts must be used for lifting operations (see maintenance manual or general arrangement drawing for lifting point positions). Failure to use the lifting points provided may result in personal injury and/or damage to the product or surrounding equipment. Keep clear of raised equipment.
- 5) Lubricants and Lubrication
 - (a) Prolonged contact with lubricants can be detrimental to the skin. The manufacturer's instruction must be followed when handling lubricants.
 - (b) The lubrication status of the equipment must be checked before commissioning. Read and carry out all instructions on the lubricant plate and in the installation and maintenance literature. Heed all warning tags. Failure to do so could result in mechanical damage and in extreme cases risk of injury to personnel.
- 6) Electrical Equipment - Observe hazard warnings on electrical equipment and isolate power before working on the gearbox or associated equipment, in order to prevent the machinery being started.
- 7) Installation, Maintenance and Storage
 - (a) In the event that equipment is to be held in storage, for a period exceeding 6 months, prior to installation or commissioning, Textron Power Transmission must be consulted regarding special preservation requirements. Unless otherwise agreed, equipment must be stored in a building protected from extremes of temperature and humidity to prevent deterioration.
The rotating components (gears and shafts) must be turned a few revolutions once a month (to prevent bearings brinelling).
 - (b) External gearbox components may be supplied with preservative materials applied, in the form of a "waxed" tape overwrap or wax film preservative. Gloves should be worn when removing these materials. The former can be removed manually, the latter using white spirit as a solvent.

Preservatives applied to the internal parts of the gear units do not require removal prior to operation.
 - (c) Installation must be performed in accordance with the manufacturer's instructions and be undertaken by suitably qualified personnel.
 - (d) Before working on a gearbox or associated equipment, ensure that the load has been removed from the system to eliminate the possibility of any movement of the machinery and isolate power supply. Where necessary, provide mechanical means to ensure the machinery cannot move or rotate. Ensure removal of such devices after work is complete.
 - (e) Ensure the proper maintenance of gearboxes in operation. Use only the correct tools and Textron Power Transmission approved spare parts for repair and maintenance. Consult the Maintenance Manual before dismantling or performing maintenance work.
- 8) Hot Surfaces and Lubricants
 - (a) During operation, gear units may become sufficiently hot to cause skin burns. Care must be taken to avoid accidental contact.
 - (b) After extended running the lubricant in gear units and lubrication systems may reach temperatures sufficient to cause burns. Allow equipment to cool before servicing or performing adjustments.
- 9) Selection and Design
 - (a) Where gear units provide a backstop facility, ensure that back-up systems are provided if failure of the backstop device would endanger personnel or result in damage.
 - (b) The driving and driven equipment must be correctly selected to ensure that the complete machinery installation will perform satisfactorily, avoiding system critical speeds, system torsional vibration, etc.
 - (c) The equipment must not be operated in an environment or at speeds, powers, torques or with external loads beyond those for which it was designed.
 - (d) As improvements in design are being made continually the contents of this catalogue are not to be regarded as binding in detail, and drawings and capacities are subject to alterations without notice.

The above guidance is based on the current state of knowledge and our best assessment of the potential hazards in the operation of the gear units.

Any further information or clarification required may be obtained by contacting Textron Power Transmission.

BAUINDUSTRIE

PAPIER & ZELLSTOFF

KFZ-TECHNIK

BERGBAU

LANDWIRTSCHAFT

TRANSPORTINDUSTRIE

CHEMIE

LEBENSMITTEL

SERVICE

MINERALSTOFFE

METALLE

WASSER

HOLZINDUSTRIE

SCHIFFFAHRT

ZEMENT

KUNSTSTOFF

ENERGIE

TEXTILINDUSTRIE

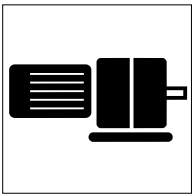

Getriebemotoren

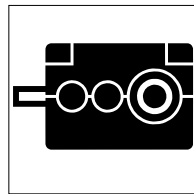

Industriegetriebe

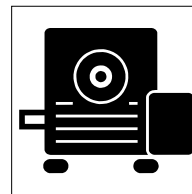

Schneckengetriebe

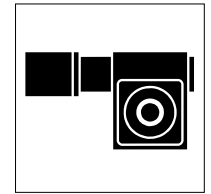

Präzisionsantriebe

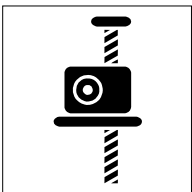

Spindelhubelemente

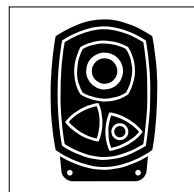

Aufsteckgetriebe

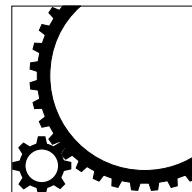

Horizontale Walzantriebe

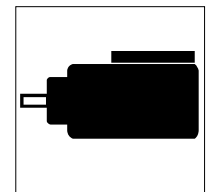

Vertikale Walzantriebe

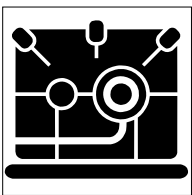

Schnelllaufgetriebe

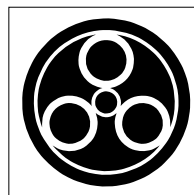

Planetengetriebe

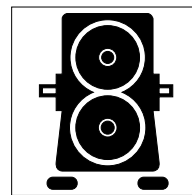

Sondergetriebe

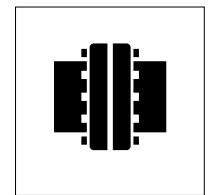

Kupplungen

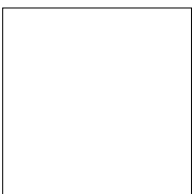

Service

ASC **ANTRIEBE
DISTRIBUTION
& SERVICE GMBH**

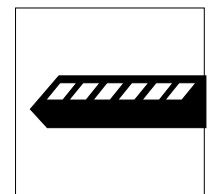

Bahnantriebe